

**Booster
&
Drainage
Pumps**



Uses:

**Agricultural
Industrial
Municipal
Irrigation
Domestic**



Where there's water, there's Pentax

PROUDLY IMPORTED BY

DPI Trading

The most trusted name in quality products & brands

www.dpitrading.co.za

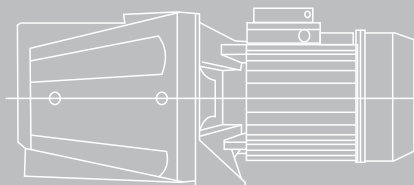

Inclledon

The most trusted name in quality products & brands

www.inclledon.co.za

CHARACTERISTICS

USES - Self-priming centrifugal pump for water supplies (even if mixed with gas) in small household systems, connected to autoclave tanks, for transferring liquids and emptying tanks; also used for gardening.

CONSTRUCTION FEATURES - Cast iron pump casing with threaded inlet and outlet; cast iron motor bracket or in aluminium; impeller in Noryl® or in brass; ceramic - graphite mechanical seal; motor shaft in AISI 416 steel; world leading brand ball bearings; liquid temperature range 0 - 50 °C; max. operating pressure 6 bar.

MOTOR - 2 pole electric induction motor for continuous operations; stator made with low-loss laminated electric sheet steel; insulation Class F; IP 44 protection level; thermal protection for single-phase models; the user is responsible for supplying protection for the three-phase models.

ON REQUEST - Other operating voltages and frequencies; special mechanical seal; special liquids.

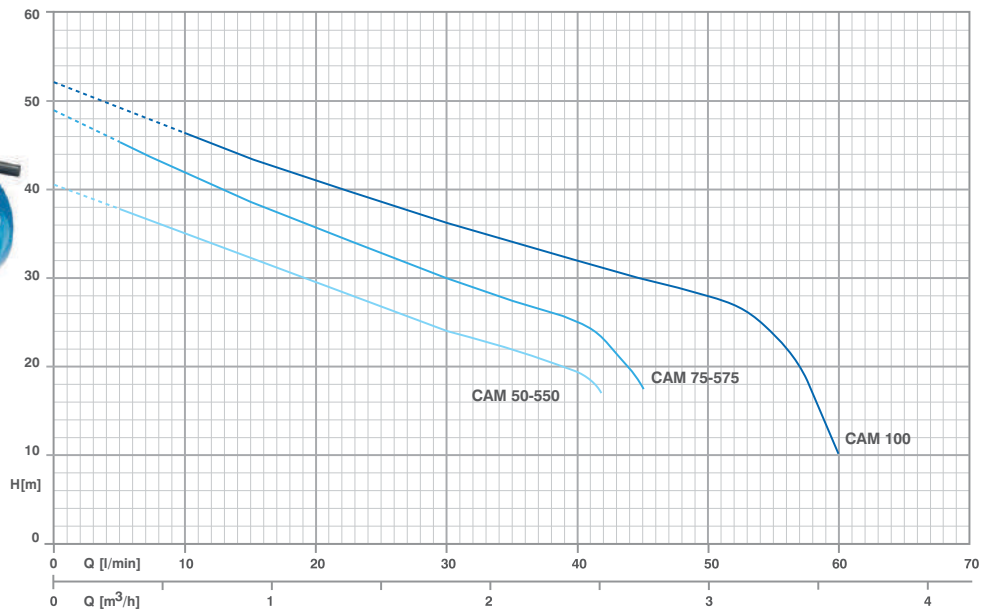

Dimensions

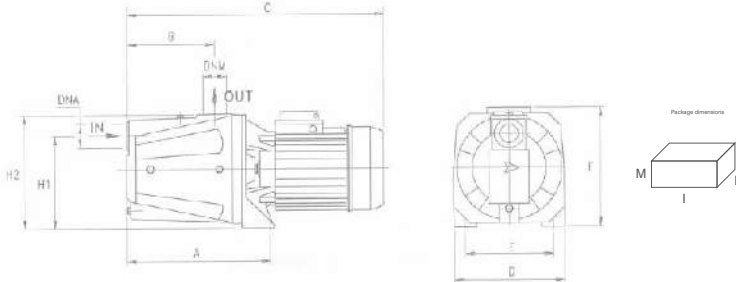

Technical data

TYPE		P2P1		(kW)		AMPERE		Q (m³/h - l/min)					
1~	3~	0.6	0.44	0.63	0.59	1~3~		0.6	1.2	1.8	2.4	3.0	3.6
230 V - 50 Hz	230 / 400 V - 50 Hz					1x230V 50Hz	3x400V 50Hz	10	20	30	40	50	60
CAM 550	CAMT 550	0.6	0.44	0.63	0.59	3	1	35	29.5	24	20	-	-
CAM 50	CAMT 50	0.6	0.44	0.69	0.65	3.2	1.2	35	29.5	24	20	-	-
CAM 575	CAMT 575	0.8	0.59	0.79	0.78	3.6	1.3	42	36	30	25	-	-
CAM 75	CAMT 75	0.8	0.59	0.8	0.81	3.7	1.4	42	36	30	25	-	-
CAM 100	CAMT 100	1	0.74	1.02	1.05	4.7	2.3	47	42	37	32	27	10

TYPE	DIMENSIONS (mm)													Kg
	A	B	C	D	E	F	H1	H2	DNA	DNM	I	L	M	
CAM 550	230	140	395	180	140	195	152	185	1"G	1"G	440	200	225	14
CAM 50	230	140	420	180	140	195	152	185	1"G	1"G	440	200	225	15.2
CAM 575	230	140	395	180	140	195	152	185	1"G	1"G	440	200	225	14.4
CAM 75	230	140	420	180	140	195	152	185	1"G	1"G	440	200	225	15.8
CAM 100	230	140	420	180	140	195	152	185	1"G	1"G	440	200	225	17

CHARACTERISTICS

USES - Self-priming centrifugal pump for water supplies (even if mixed with gas) in small household systems, connected to autoclave tanks for transferring liquids and emptying tanks; used in medium sized industrial applications and for gardening.

CONSTRUCTION FEATURES - AISI 303 stainless steel pump casing with threaded inlet and outlet; aluminium motor bracket and AISI 303 stainless steel mechanical seal holder; Noryl[®] impeller for INOXR; AISI 304 stainless-steel or Noryl[®] for all other models; ceramic - graphite mechanical seal; motor shaft in AISI 416 steel; world leading brand ball bearings; liquid temperature range 0 - 50 °C; max. operating pressure 6 bar.

MOTOR - 2 pole electric induction motor for continuous operations; stator made with low-loss laminated electric sheet steel Insulation Class F; IP 44 protection level; thermal protection for single-phase models; the user is responsible for supplying protection for the three-phase models.

ON REQUEST - Other operating voltages and frequencies; special mechanical seal; special liquids.

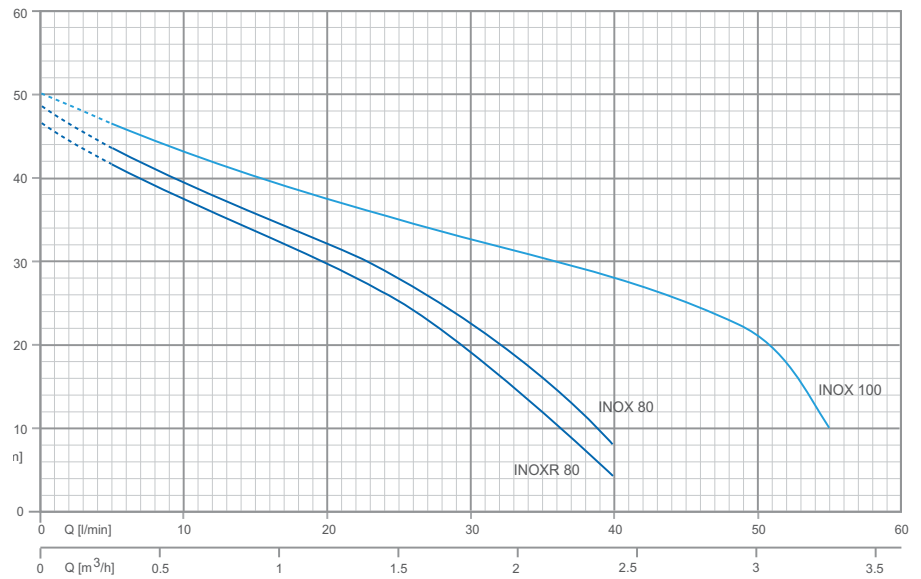

Dimensions

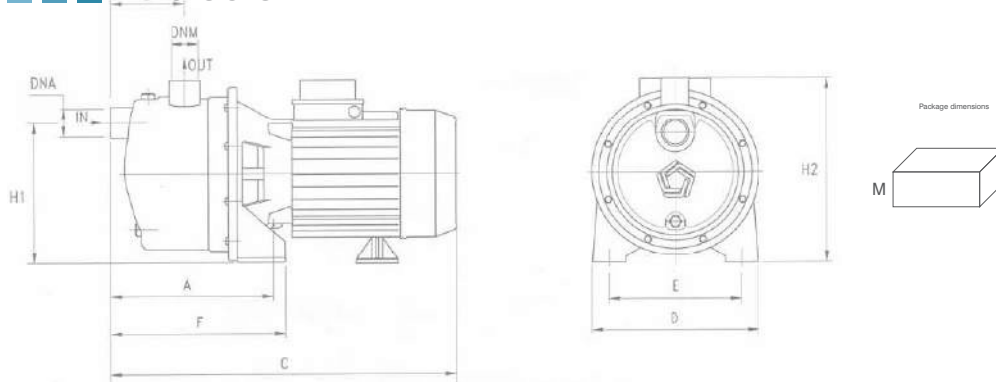

Technical data

TYPE		P2P1		(kW)		AMPERE							
1~	3~	(HP)	(kW)			1~3~		0	0.6	1.2	1.8	2.4	3.0
230 V - 50 Hz	230 / 400 V - 50 Hz			1~3~		1x230V 50Hz	3x400V 50Hz	0	10	20	30	40	50
INOXR 80	INOXRT 80	0.8	0.59	0.78	0.79	3.6	1.4	46.5	37	29.5	19.2	4	-
INOX 80	INOXT 80	0.8	0.59	0.79	0.79	3.7	1.4	48.5	39	32	22.4	7.6	-
INOX 100	INOXT 100	1	0.74	0.98	1	4.6	2.2	50	43	38	32	28	21

TYPE	DIMENSIONS (mm)													
	A	B	C	D	E	F	H1	H2	DNA	DNM	I	L	M	
INOXR 80	165	79	352	175	140	175	150	199	1"G	1"G	400	210	235	7.9
INOX 80	165	79	360	175	140	175	150	199	1"G	1"G	400	210	235	8.7
INOX 100	165	79	360	175	140	175	150	199	1"G	1"G	400	210	235	9.9

CHARACTERISTICS

USES - Self-priming centrifugal pump for water supplies (even if mixed with gas) in small and medium household and civil systems; when connected to autoclave tanks, an automatic pressurisation system comes.

CONSTRUCTION FEATURES - Cast iron pump casing with threaded inlet and outlet; cast iron motor bracket; impeller in Noryl® or in brass; ceramic - graphite mechanical seal; motor shaft in AISI 303 steel on the hydraulic side; world leading brand ball bearings; liquid temperature range 0 - 50 °C; max. operating pressure 6 bar.

MOTOR - 2 pole electric induction motor for continuous operations; stator made with low-loss laminated electric sheet steel; insulation Class F; IP 44 protection level; thermal protection for single-phase models; the user is responsible for supplying protection for the three-phase models.

ON REQUEST - Other operating voltages and frequencies; special mechanical seal; special liquids.

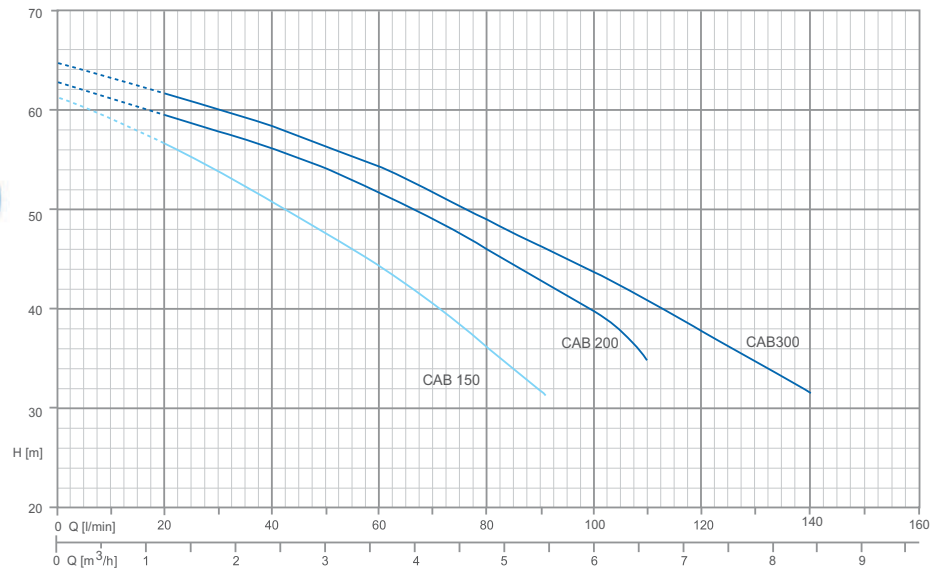

Dimensions

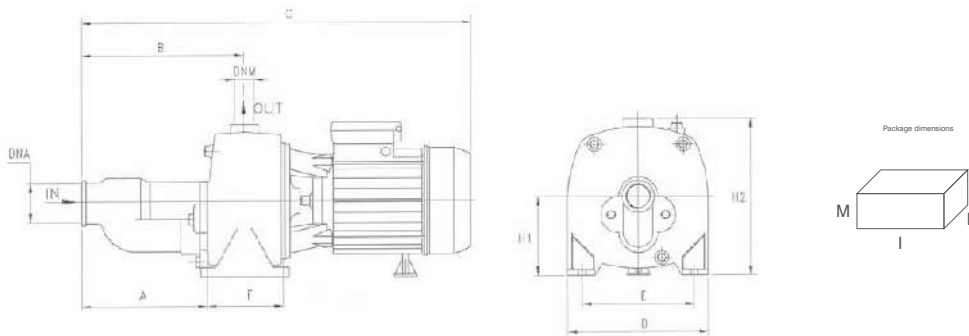

Technical data

TYPE		P2P1		(kW)		AMPERE		Q (m³/h - l/min)								
1~	3~					1~3~		0	1.2	1.8	3	4.2	5.4	6.6	7.8	8.4
230 V - 50 Hz	230 / 400 V - 50 Hz	(HP)	(kW)	1~3~		1x230V 50Hz	3x400V 50Hz	0	20	30	50	70	90	110	130	140
								H (m)								
CAB 150	CABT 150	1.5	1.1	1.74	1.68	7.9	3.3	61	56.5	54	48	41	32	-	-	-
CAB 200	CABT 200	2.2	1.65	2.22	2.1	10.3	3.9	62.5	59.5	58	54	49	42.5	34	-	-
CAB 300	CABT 300	3	2.2	2.65	2.5	11.8	4.9	64.5	62	60.5	57	52.5	47	42	35	32

TYPE	DIMENSIONS (mm)										Package dimensions			Kg
	A	B	C	D	E	F	H1	H2	DNA	DNM	I	L	M	
CAB 150	204	257	596	220	177	105	112	240	1"1/2 G	1"G	610	235	275	27.9
CAB 200	204	257	596	220	177	105	112	240	1"1/2 G	1"G	610	235	275	28.7
CAB 300	204	257	596	220	177	105	112	240	1"1/2 G	1"G	610	235	275	29.6

CHARACTERISTICS

USES - Peripheral pumps with frontal pumps for small household systems and simple industrial applications; characterised by a considerable ratio between performance and required output.

CONSTRUCTION FEATURES - Cast iron pump casing (mod. PM) with threaded intake and delivery openings ; pump casing available in bronze (mod. PM45-Br) ; cast iron motor bracket or bronze on request (mod. PM45-Br); radial blade brass impeller; ceramic - graphite mechanical seal; motor shaft in AISI 416 steel ; world leading brand ball bearings; liquid temperature range 0 - 90 °C; max. operating pressure 6 bar (8 bar for PM80).

MOTOR - 2 pole electric induction motor for continuous operations; stator made with low-loss laminated electric sheet steel; insulation Class F; IP 44 protection level; thermal protection for single-phase models; the user is responsible for supplying protection for the three-phase models.

ON REQUEST - Other operating voltages and frequencies; special mechanical seal; special liquids.

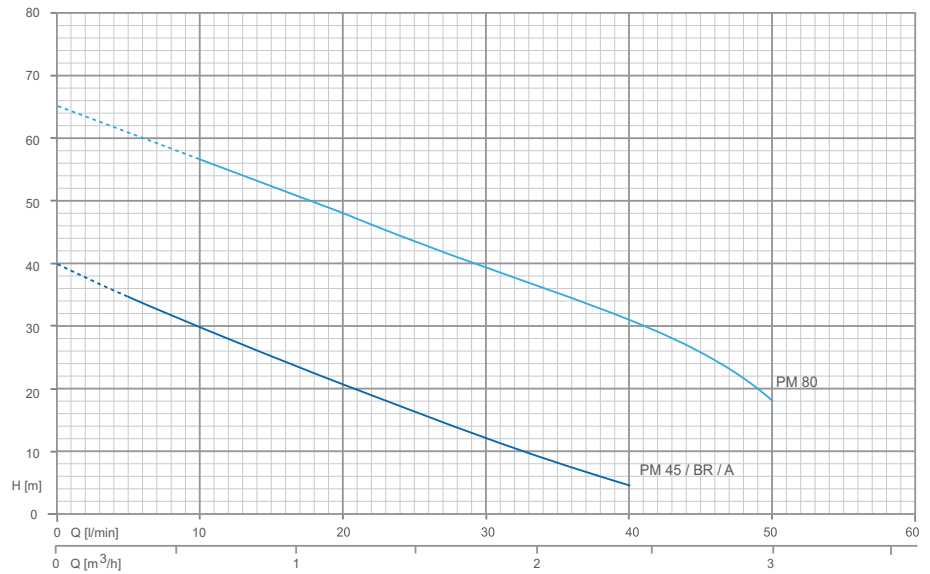

Dimensions

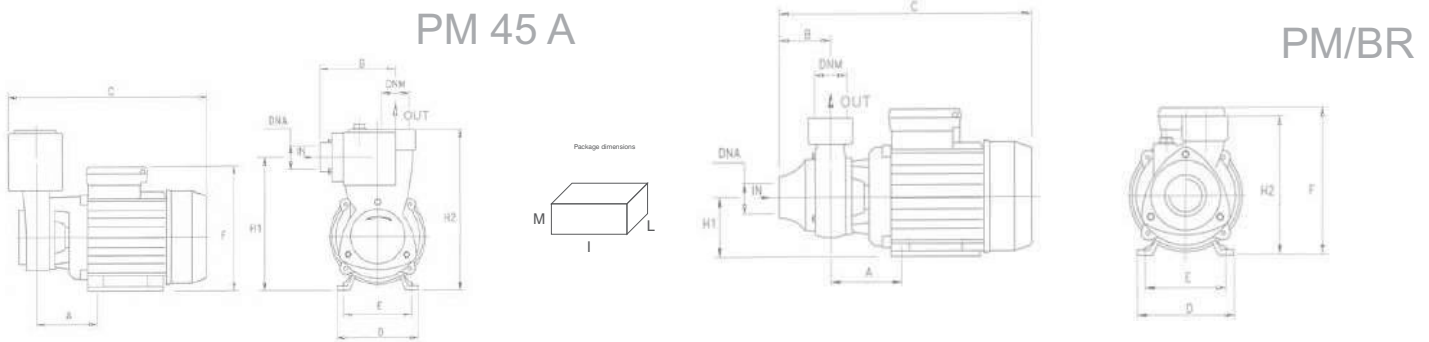

Technical data

TYPE		P2P1		(kW)		AMPERE							
1~	3~	(HP)	(kW)	1~3~		1~3~		0.3	0.6	1.2	1.8	2.4	3
230 V - 50 Hz	230 / 400 V - 50 Hz			1~3~		1x230V 50Hz	3x400V 50Hz	5	10	20	30	40	50
PM 45	PMT 45	0.5	0.37	0.49	0.5	2.3	1	35	30	21	13	5	-
PM 45 BR	PMT 45 BR	0.5	0.37	0.49	0.5	2.3	1	35	30	21	13	5	-
PM 45 A	PMT 45 A	0.5	0.37	0.49	0.5	2.3	1	35	30	21	13	5	-
PM 80	PMT 80	1	0.74	1.11	1.11	5.2	2	-	56	48	39	31	18

TYPE	DIMENSIONS (mm)														Kg
	A	B	C	D	E	F	H1	H2	DNA	DNM	I	L	M		
PM 45 (BR)	63	50	260	120	97	153	65	143	1"G	1"G	265	150	165	5.7	
PM 45 A	62	89	240	120	97	155	150	184	1"G	1"G	260	160	225	6	
PM 80	71.5	50	290	135	112	172	75	164	1"G	1"G	310	185	195	9.5	

CHARACTERISTICS

USES - Peripheral pumps with side suction pumps for small household systems and simple industrial applications; characterised by a considerable ratio between performance and required output. The CP model has a frontal brass inset avoiding the risk of blockage.

CONSTRUCTION FEATURES - Cast iron and brass pump casing with threaded intake and delivery openings; radial blade brass impeller; ceramic - graphite mechanical seal; motor shaft in AISI 416 steel ; world leading brand ball bearings; liquid temperature range 0 - 90 °C; max. operating pressure 6 bar (8 bar for CP75).

MOTOR - 2 pole electric induction motor for continuous operations; stator made with low-loss laminated electric sheet steel; insulation Class F; IP 44 protection level; thermal protection for single-phase models; the user is responsible for supplying protection for the three-phase models.

ON REQUEST - Other operating voltages and frequencies; special mechanical seal; special liquids.



CP 75

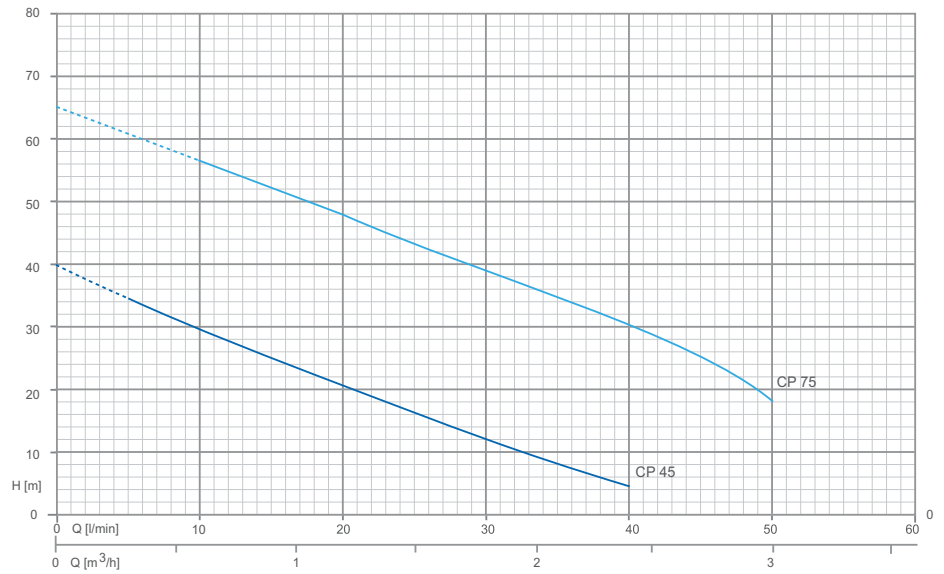

Dimensions

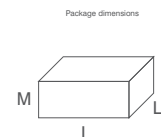
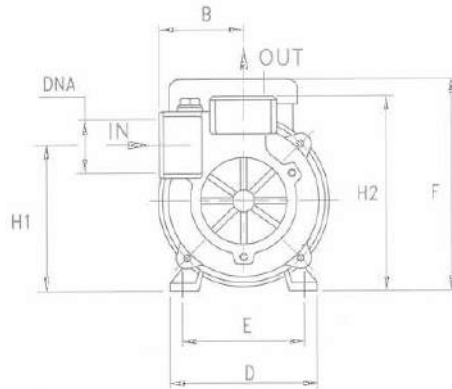
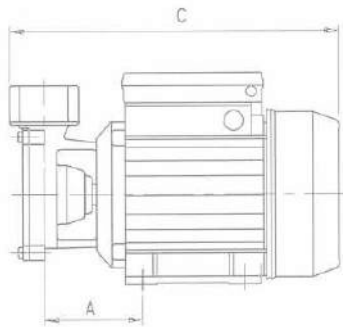

Technical data

TYPE	DIMENSIONS (mm)													Kg
	A	B	C	D	E	F	H1	H2	DNA	DNM	I	L	M	
CP 45	67	60	235	120	97	165	105	140	1"G	1"G	265	145	165	5.6
CP 75	71.5	60	263	135	112	172	124	156	1"G	1"G	310	185	195	9.5

TYPE		P2P1		(kW)		AMPERE							
1~	3~	(HP)	(kW)	1~3~		1~3~		0.3	0.6	1.2	1.8	2.4	3
230 V - 50 Hz	230 / 400 V - 50 Hz					1x230V 50Hz	3x400V 50Hz	5	10	20	30	40	50
CP 45	CPT 45	0.5	0.37	0.49	0.5	2.3	1.0	35	30	21	13	5	-
CP 75	CPT 75	1	0.74	1.11	1.13	5.2	2.0	61	56	48	39	31	18

CHARACTERISTICS

USES - Liquid ring pump with star impeller that gives considerable suction power to the pump. Particularly suitable for liquid transfer (including volatile liquids). The MD model has a frontal brass inset avoiding the risk of blockage.

CONSTRUCTION FEATURES - Cast iron and brass pump casing with threaded openings (side intake); cast iron motor bracket; brass star impeller; ceramic - graphite mechanical seal; motor shaft in AISI 416 steel; world leading brand ball bearings; liquid temperature range 0 - 90 °C; max. operating pressure 8 bar.

MOTOR - 2 pole electric induction motor for continuous operations; stator made with low-loss laminated electric sheet steel; insulation Class F; IP 44 protection level; thermal protection for single-phase models; the user is responsible for supplying protection for the three-phase models.

ON REQUEST - Other operating voltages and frequencies; special mechanical seal; special liquids.

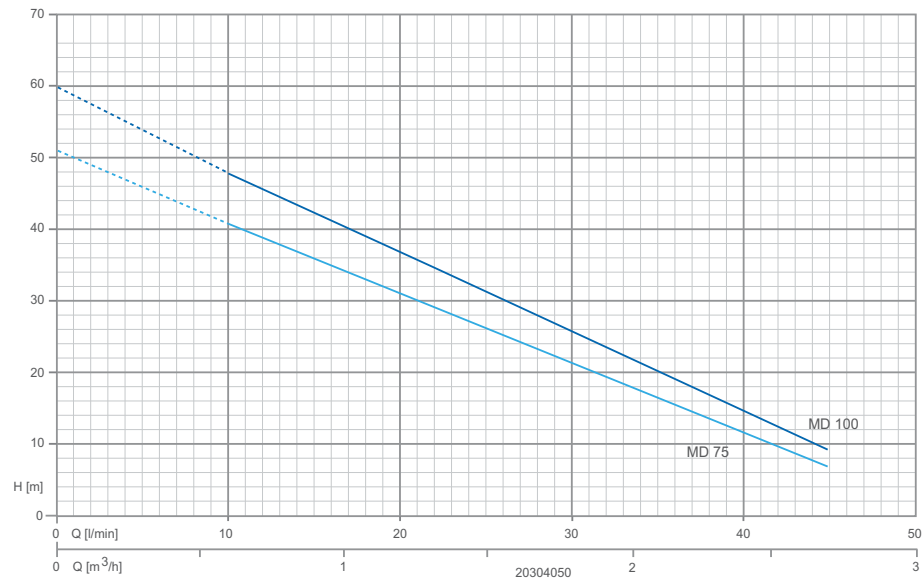

Dimensions

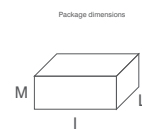
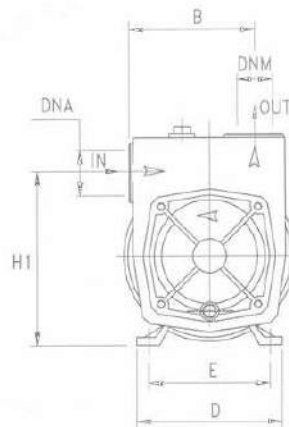
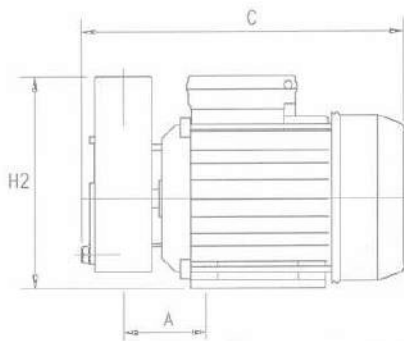

Technical data

TYPE / MODELO / MODÈLE / МОДЕЛЬ		P2P1		(kW)		AMPERE								
1~	3~	(HP)	(kW)	1~3~		1~3~		0.3	0.6	1.2	1.8	2.4	2.7	
								5	10	20	30	40	45	
230 V - 50 Hz	230 / 400 V - 50 Hz					1x230V 50Hz	3x400V 50Hz							
MD 75	MDT 75	0.8	0.59	1.03	0.94	5.0	1.7	46	41	31.5	21.5	11.5	6	
MD 100	MDT 100	1	0.74	1.17	0.98	5.4	2.1	53	48	37	25	13.5	9	

TYPE	DIMENSIONS (mm)												
	A	B	C	D	E	H1	H2	DNA	DNM	I	L	M	
MD 75	70	98.5	270	135	112	141	170	1"G	1"G	310	185	195	11.1
MD 100	70	98.5	270	135	112	141	170	1"G	1"G	310	185	195	11.6

CHARACTERISTICS

USES - Single impeller centrifugal pumps, extremely silent suitable for household, civil and industrial applications, with a very flat curve to guarantee constant pressure even when the delivery volumes vary.

CONSTRUCTION FEATURES - Cast iron pump casing with threaded openings; cast iron motor bracket and aluminium on models CM75 and CM100.; impeller in Noryl® or in brass (models CM50, CM75 and CM100). Brass rotor on models CM 160-314; ceramic - graphite mechanical seal; motor shaft in AISI 416 steel for CM 50-75-100, in AISI 303 the hydraulic side in other models; world leading brand ball bearings; liquid temperature range 0 - 90 °C (0 - 50 °C if impeller in Noryl® or aluminium support) ; max. operating pressure 6 bar for models CM50, CM75, CM100, 8 bar for larger models).

MOTOR - 2 pole electric induction motor for continuous operations; stator made with low-loss laminated electric sheet steel; insulation Class F; IP 44 protection level; thermal protection for single-phase models; the user is responsible for supplying protection for the three-phase models.

ON REQUEST - Other operating voltages and frequencies; special mechanical seal; special liquids.

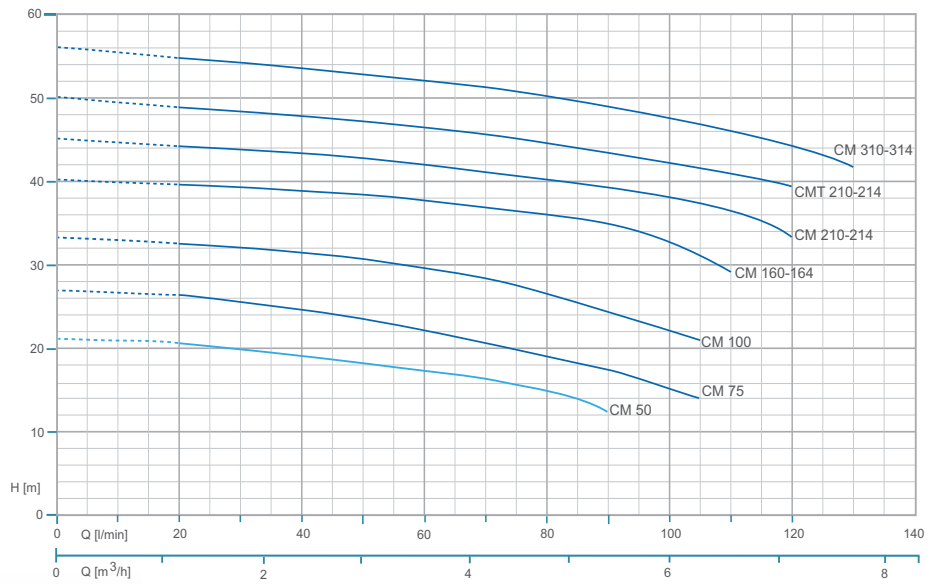

Dimensions

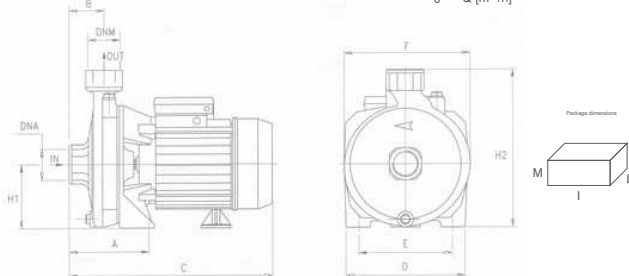

Technical data

TYPE		P2P1		(kW)		AMPERE		Q (m³/h - l/min)									
1~	3~	(HP)	(kW)	1~3~		1~3~		0	1.2	2.4	3.6	4.8	5.4	6.6	7.2	7.8	
230 V - 50 Hz		230 / 400 V - 50 Hz				1x230V	3x400V	0	20	40	60	80	90	110	120	130	
						50Hz	50Hz										
CM 50	CMT 50	0.5	0.37	0.59	0.65	2.8	1.1	21.5	20.5	19	17	15	12	-	-	-	
CM 75	CMT 75	0.8	0.59	0.9	0.94	4.5	1.7	26.5	26	24.5	22	19.5	17.5	-	-	-	
CM 100	CMT 100	1	0.74	1.16	1.17	5.7	2.0	33	32.5	31.5	29.5	27	25	-	-	-	
CM 160	CMT 160	1.5	1.1	1.9	1.8	8.5	3.4	40.5	39.3	38.6	37.5	35.6	34.6	29.5	-	-	
CM 210	-	2.2	1.65	2.2	-	10.3	-	45.1	44.1	43.3	42.3	40.5	39.2	36.4	33.5	-	
-	CMT 210	2.2	1.65	-	2.43	-	4.9	50	48.7	47.8	46.5	44.9	43.7	41.3	39.4	-	
CM 310	CMT 310	3	2.2	2.85	2.67	13.5	5.1	55.9	54.5	53.4	52	50.1	48.9	46.2	44.2	41.9	
CM 164	CMT 164	1.5	1.1	1.9	1.8	8.5	3.4	40.5	39.3	38.6	37.5	35.6	34.6	29.5	-	-	
CM 214	-	2.2	1.65	2.2	-	10.3	-	45.1	44.1	43.3	42.3	40.5	39.2	36.4	33.5	-	
-	CMT 210	2.2	1.65	-	2.43	-	4.9	50	48.7	47.8	46.5	44.9	43.7	41.3	39.4	-	
CM 314	CMT 314	3	2.2	2.85	2.67	13.5	5.1	55.9	54.5	53.4	52	50.1	48.9	46.2	44.2	41.9	

TYPE	DIMENSIONS (mm)										Kg			
	A	B	C	D	E	F	H1	H2	DNA	DNM	I	L	M	
CM 50	95	45.5	265	150	110	160	82	202	1°G	1°G	290	175	225	9
CM 75	110	46.5	300	180	140	185	97	234	1°G	1°G	325	200	265	12.7
CM 100	110	46.5	300	180	140	185	97	234	1°G	1°G	325	200	265	14
CM 160	117	46.5	348	220	180	225	115	285	1°G	1°G	370	240	315	22.5
CM 164	117	46.5	348	220	180	225	115	285	1 1/4 G	1°G	370	240	315	22.5
CM 210	117	46.5	348	220	180	225	115	285	1°G	1°G	370	240	315	23
CM 214	117	46.5	348	220	180	225	115	285	1 1/4 G	1°G	370	240	315	23
CM 310	117	46.5	348	220	180	225	115	285	1°G	1°G	370	240	315	23.5
CM 314	117	46.5	348	220	180	225	115	285	1 1/4 G	1°G	370	240	315	23.5

CHARACTERISTICS

USES - Single impeller centrifugal pumps, extremely silent suitable for household, civil and industrial applications, with a very flat curve to guarantee constant pressure even when the delivery. Volumes vary.

CONSTRUCTION FEATURES - Cast iron pump casing with threaded openings; cast iron motor bracket; impeller in brass Ceramic - graphite mechanical seal; motor shaft in AISI 303 the hydraulic side; world leading brand ball bearings; liquid temperature range 0 - 90 °C; max. operating pressure 8 bar.

MOTOR - 2 pole electric induction motor for continuous operations; stator made with low-loss laminated electric sheet steel; insulation Class F; IP 44 protection level; the user is responsible for supplying thermal protection for the three-phase models.

ON REQUEST - Other operating voltages and frequencies; special mechanical seal; special liquids.

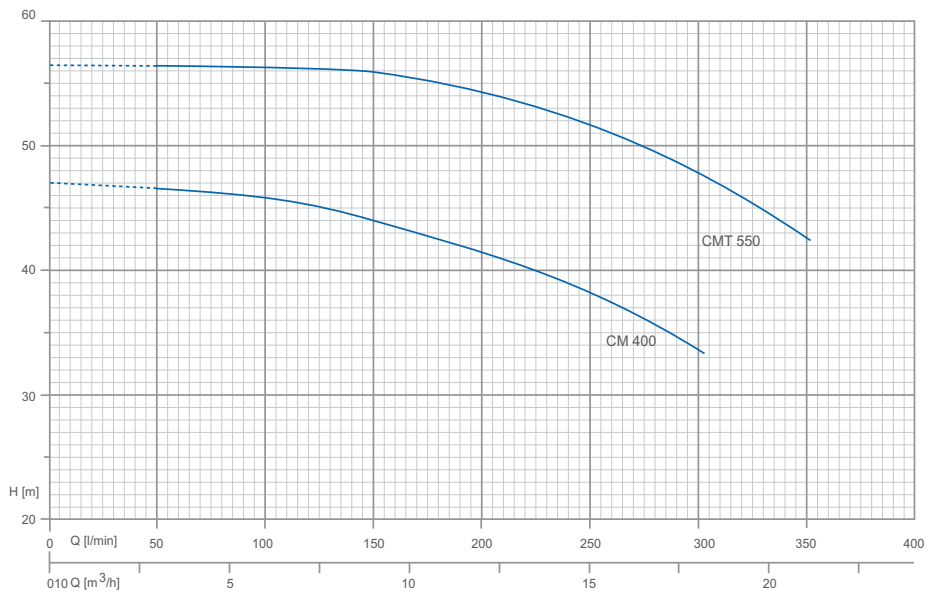

Dimensions

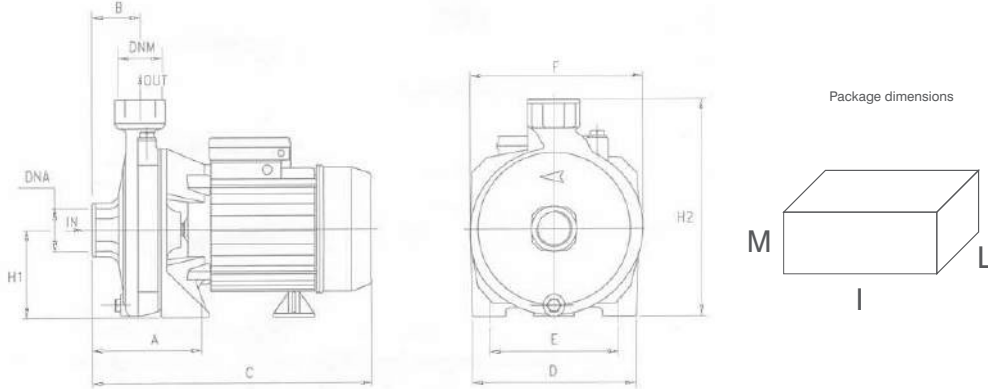

Technical data

TYPE	DIMENSIONS (mm)										Package dimensions			Kg
	A	B	C	D	E	F	H1	H2	DNA	DNM	I	L	M	
CM 400	108	54	425	240	190	250	133	323	2 "G	1"1/4 G	440	270	360	39.8
CMT 550	108	54	425	240	190	250	133	323	2 "G	1"1/4 G	440	270	360	39.8

TYPE		P2P1		(kW)		AMPERE		Q (m³/h - l/min)							
1~	3~	(HP)	(kW)	1~3~		1~3~		0	3	6	9	12	15	18	21
230 V - 50 Hz	230 / 400 V - 50 Hz					1x230V 50Hz	3x400V 50Hz	0	50	100	150	200	250	300	350
CM 400	CMT 400	4	3	4.2	4	18.5	6.8	47	46.7	45.8	44.2	41.5	38	33.5	-
-	CMT 550	5.5	4	-	5.5	-	9.6	56.5	56.5	56.5	56	54.5	51.8	47.9	42.5

CHARACTERISTICS

USES - Monobloc horizontal centrifugal pumps, constructed to EN 733 standards; widely used in water supplies, pressurisation and fire-fighting systems, standard supply with screwed mating flange.

CONSTRUCTION FEATURES - Cast iron pump casing with standardised flanged openings; cast iron motor bracket; impeller in cast iron, on request in bronze; ceramic - graphite mechanical seal; motor shaft in AISI 304 steel on the hydraulic side; world leading brand ball bearings; liquid temperature range 0 - 90 °C; max. operating pressure 10 bar.

MOTOR - 2 pole electric induction motor for continuous operations; stator made with low-loss laminated electric sheet steel; insulation Class F; IP 55 protection level; the user is responsible for supplying thermal protection on all models.

ON REQUEST - Other operating voltages and frequencies; special mechanical seal; special liquids.



Dimensions

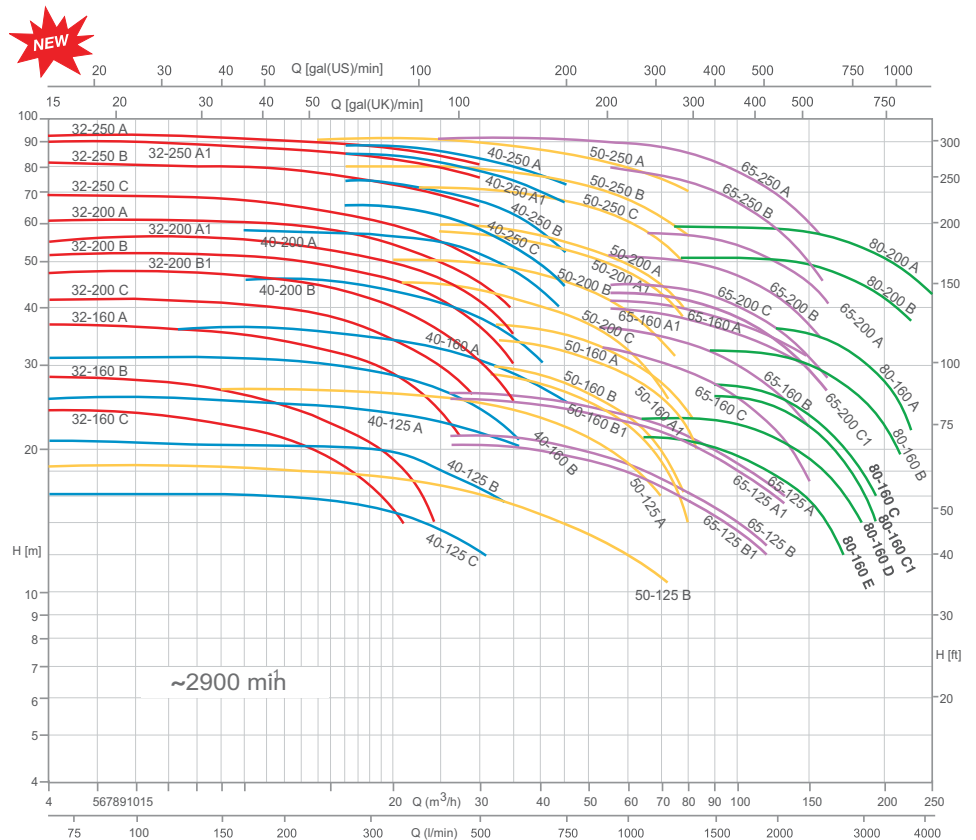

Technical data

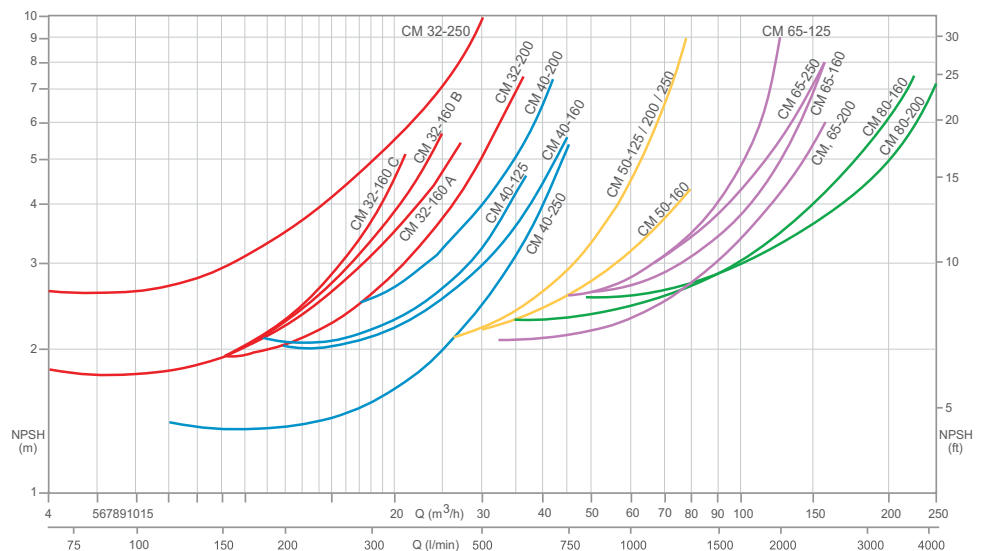

Technical data

DIMENSIONS (mm)				
DN	D	K	holes	
			n°	∅
32	140	100	4	18
40	150	110	4	18
50	165	125	4	18
65	185	145	4	18
80	200	160	4	18
100	220	180	8	18

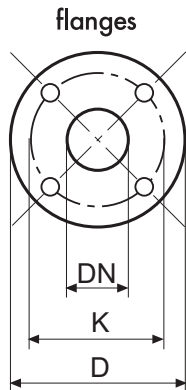

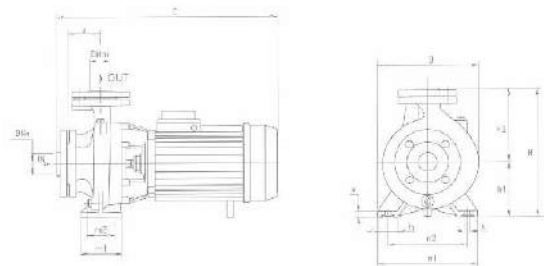

TYPE	P ₂ nom. (HP)(kW)	P ₂ nom. (kW)	P ₁ max. (kW)	I 3x400V																	
					0	4.5	6	7.5	9	12	15	18	21								
					0	75	100	125	150	200	250	300	350								
CM 32-160 C (*)	2	1.5	2.3	4	24.7	24.4	24.1	23.6	23	21.5	19.6	17.2	14.1								
CM 32-160 B (*)	3	2.2	2.9	5.2	29			28.5	28	27.3	25.7	23.8	21.4	18.5							
CM 32-160 A	4	3	4.1	7.1	36.8			36.4	36	35.4	34.2	32.8	31.1	28.8							
CM 32-200 C (*)	5.5	4	5.2	9.4	41.0			40.0	39.5	38.9	37.5	36.0	34.2	32.2							
CM 32-200B1	7.5	5.5	6.6	11.3	48.0			47.5	47.1	46.6	45.5	44.3	42.5	40.7							
CM 32-200 B	7.5	5.5	8	13.7	52.8			52.0	51.5	51.0	50.0	48.5	46.8	45.0							
CM32 200A1	10	7.5	8.5	14.6	56.5			56.0	55.6	55.2	54.0	52.8	51.0	49.2							
CM 32-200 A	10	7.5	9.9	16.5	61.0			60.5	60.1	59.6	58.5	57.2	55.5	53.7							
CM 32-250 C	12.5	9.2	11.9	20.1	70					68.5	68.0	67.0	65.5	63.5	61.5						
CM 32-250 B	15	11	14.4	24.2	82					81.0	80.5	79.5	78.5	77.0	75						
CM 32-250 A1	20	15	16	27.4	91.0					90.0	89.9	89.0	88.0	86.0	84.0						
CM 32-250 A	20	15	18.1	30.1	93.0					92.5	92.0	91.5	90.5	89.5	88.0						
CM 40-125 C (*)	2	1.5	2.3	4	17.4					17.6	17.5	17.3	16.9	16.4	15.8						
CM 40-125 B (*)	3	2.2	2.9	5.2	20.7						21.3	21.2	21.0	20.6	20.1						
CM 40-125 A	4	3	4.1	7.1	25.2						25.8	25.8	25.6	25.4	24.9						
CM 40-160 B (*)	4	3	4.4	7.4	30.0						30.1	30.0	29.6	29.0	28.2						
CM 40-160 A (*)	5.5	4	5.7	9.9	35.4						35.6	35.5	35.3	35.0	34.2						
CM 40-200 B	7.5	5.5	7.8	13.2	46.7						47.0	46.8	46.4	45.6	44.5						
CM 40-200 A	10	7.5	10.2	16.8	56.4						57.8	58.0	57.9	57.6	56.9						
CM 40-250 C	12.5	9.2	12.6	21	65.0						64.3	63.9	63.3	62.6	61.5						
CM 40-250 B	15	11	14.4	24.2	75.5						74.6	74.2	73.5	72.7	71.7						
CM 40-250 A1	20	15	17.5	29.5	85						84.0	83.7	82.9	82.1	80.8						
CM 40-250 A	20	15	19	32	91.5						90.4	89.9	89.3	88.5	87.5						
CM 50-125 B (*)	4	3	4.4	7.4	19.9							20.2	20.2	20.1	20.0						
CM 50-125 A (*)	5.5	4	5.7	9.9	24.5								25.0	24.9	24.8						
CM 50-160 B1	7.5	5.5	6.2	10.7	29.3															30.3	
CM 50-160 B	7.5	5.5	6.7	11.6	31.1																32.1
CM 50-160 A1	10	7.5	8.3	14.1	34.3																35.4
CM 50-160 A	10	7.5	9.4	15.8	36.7																37.9
CM 50-200 C	12.5	9.2	10.8	18.5	46.0																
CM 50-200 B	15	11	12.4	21	50.8																
CM 50-200 A1	20	15	14.5	25.4	57.0																
CM 50-200 A	20	15	15.4	27	58.0																
CM 50-250 C	20	15	20	32.5	71.5																
CM 50-250 B	25	18.5	23	41.5	78.0																
CM 50-250 A	30	22	28.5	51.5	90.0																
CM 65-125 B1	7.5	5.5	6.4	11	19.4																
CM 65-125 B	7.5	5.5	7.2	12.6	20.9																
CM 65-125 A1	10	7.5	8.1	14.0	23.0																
CM 65-125 A	10	7.5	9.5	16.3	25.4																
CM 65-160 C	12.5	9.2	11.7	19.5	29.8																
CM 65-160 B	15	11	13	22.5	33.0																
CM 65-160 A1	20	15	15.8	27.6	37.1																
CM 65-160 A	20	15	18	30	39.2																
CM 65-200 C1	20	15	17.4	29.2	39.7																
CM 65-200 C	20	15	20	32.5	42.3																
CM 65-200 B	25	18.5	23	41.5	46.8																
CM 65-200 A	30	22	28.5	51.5	54.0																
CM 65-250 B	40	30	37.8	63.5	81.0																
CM 65-250 A	50	37	45	74.5	90.0																
CM 80-160 E	12.5	9.2	9.9	17.2	21.4																
CM 80-160 D	15	11	12.7	22.1	25.4																
CM 80-160 C1	20	15	14.8	25.5	28.5																
CM 80-160 C	20	15	15.9	27.4	29.7																
CM 80-160 B	25	18.5	20.1	34.8	34																
CM 80-160 A	30	22.5	23.7	39.8	38.8																
CM 80-200 B	40	30	37.8	63.5	49.0																
CM 80-200 A	50	37	45	74.5	58.0																

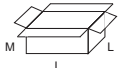

(*) Single phase available / Disponible en version monophasée / Disponible en versión monofásica / Наличие также однофаз а

Q (m³/h - l/min)																									
24	27	30	33	36	39	42	48	54	60	66	72	78	84	96	108	120	132	144	156	168	180	195	210	225	240
400	450	500	550	600	650	700	800	900	1000	1100	1200	1300	1400	1600	1800	2000	2200	2400	2600	2800	3000	3250	3500	3750	4000
H (m)																									
14.8																									
26	22.3																								
30.0	27.0																								
38.5	35.7	32.5	28.6																						
42.7	40.1	37.0	33.3	28.7																					
47.0	44.2	41.0	37.1	33.0																					
51.5	49.0	46.2	42.7	38.5																					
58.7	55	50.5																							
72.6	70	66.5																							
81.5	79.0	75.5																							
85.7	83.5	80.0																							
15.1	14.2	13.3																							
19.4	18.7	17.9	17.0																						
24.4	23.7	22.9	22.0	21.1																					
27.1	25.9	24.4	22.8	21.0																					
33.2	32.0	30.6	29.0	27.3	25.4																				
43.2	41.6	39.9	37.9	35.8	33.4																				
56.0	54.7	53.0	51.1	48.9	46.5	43.9																			
60.2	58.8	56.9	54.5	51.6	48.5	45.5																			
70.4	69.0	67.2	65.0	62.5	59.5	56.0																			
79.5	77.8	75.9	73.8	71.3	68.4	65.8																			
86.6	85.5	84.0	82.5	80.5	78.5	76.0																			
19.8	19.3	19.1	18.7	18.3	17.8	17.4	16.4	15.3	14.0	12.7	11.2														
24.6	24.4	24.2	23.8	23.5	23.1	22.7	21.8	20.8	19.6	18.1	16.5														
30.2	30.0	29.6	29.0	28.4	27.7	26.9	25.2	23.2	21.0	18.7	16.1	13.2													
32.0	31.7	31.4	31.0	30.4	29.7	28.9	27.3	25.3	23.1	20.7	18.0	15.2													
35.3	35.0	34.7	34.3	33.8	33.2	32.4	30.7	28.7	26.5	24.3	21.8	19.0													
37.8	37.7	37.4	37.1	36.6	36.1	35.4	33.9	32.1	30.0	27.8	25.3	22.6													
45.6	45.1	44.5	43.7	42.9	41.8	40.8	38.5	35.9	33.0	29.0	24.5														
51.0	50.5	50.0	49.3	48.5	47.7	46.8	44.7	42.2	39.5	35.9	32.0														
57.3	57.1	56.7	56.2	55.6	54.8	54.1	52.2	50.2	47.5	44.0	40.0														
58.3	58.0	57.5	57.0	56.4	55.7	55.0	53.2	51.3	49.0	46.3	42.8	38.8													
	70.8	70.3	69.7	69.0	68.3	67.6	66.0	64.0	61.5	58.6	55.0	50.5													
	78.0	77.4	76.8	76.1	75.3	74.5	72.8	70.6	68.2	65.5	62.2	58.3													
	89.5	88.8	88.3	87.7	86.9	86.1	84.5	82.7	80.5	78	75.2	71.7													
		20.4	20.4	20.3	20.2	20.1	19.8	19.4	19.0	18.5	17.9	17.2	16.5	15.0	13.3	11.1									
		22.0	22.0	21.9	21.8	21.7	21.4	21.0	20.6	20.1	19.6	19.0	18.3	16.6	14.7	12.6									
		24.1	24.1	24.0	23.9	23.8	23.6	23.3	23.0	22.7	22.3	21.8	21.2	19.7	17.8	15.7									
		26.4	26.4	26.4	26.3	26.3	26.1	25.9	25.6	25.3	24.9	24.5	24.0	22.7	21.0	18.9	16.5								
						31.2	31.1	30.8	30.5	30.1	29.6	29.0	28.3	26.6	24.6	22.1	19.3	16.0							
						34.6	34.4	34.2	34.0	33.7	33.3	32.8	32.1	30.6	28.8	26.7	24.1	21.1							
						38.5	38.3	38.1	37.8	37.5	37.1	36.7	36.1	34.6	32.8	30.7	28.4	25.7							
						40.6	40.6	40.4	40.2	40.0	39.7	39.4	38.9	37.7	36.2	34.3	32.2	29.8							
							41.5	41.4	41.0	40.5	39.9	39.0	36.8	34.2	31.1	27.8									
							44.8	44.5	44.1	43.7	43.0	42.3	40.5	38.0	35.3	32.0									
							49.5	49.3	49.0	48.5	48.0	47.3	45.5	43.5	41.0	38.0									
							56.7	56.5	56.2	55.7	55.2	54.7	53.3	51.6	49.6	47.1	44.0								
							79.5	78.5	77.3	76.0	74.5	73.0	69.3	65.0	60.0	54.5	48.5								
							89.5	88.5	87.5	86.5	85.5	84.0	80.5	76.5	72.0	66.5	60.5	54.0							
										22.4	22.1	21.6	21.2	20.2	19.2	18.0	16.8	15.4	13.7	12.0					
										26.4	26.1	25.7	25.3	24.4	23.6	22.5	21.3	20.0	18.5	16.9	15.1				
										29.5	29.3	29.0	28.6	27.8	26.9	25.7	24.6	23.3	21.7	19.9	17.9	15.2			
										30.7	30.5	30.3	29.9	29.2	28.1	27.1	26.0	24.7	23.1	21.5	19.7	17.2			
										35.0	35.0	34.8	34.6	34.0	33.3	32.5	31.6	30.5	29.2	27.8	26.0	2.36	21.0		
										39.8	39.7	39.6	9.4	38.9	38.2	37.5	36.7	35.7	34.5	33.2	31.6	29.4	26.8	23.5	
													50.8	50.6	50.3	49.8	49.3	48.6	47.7	46.7	45.5	43.8	41.5	38.6	
														59.6	59.2	58.6	58.0	57.3	56.4	55.5	54.3	52.7	50.8	48.5	46.1

series	DIMENSIONS (mm)																	 Kg	
	DNm	DNa	a	h1	h2	m1	m2	n1	n2	b	x	s	C	B	H	I			L
CM 32-160 C	32	50	80	132	160	100	70	240	190	50	12	14	490	240	292	520	260	355	38
CM 32-160 B	32	50	80	132	160	100	70	240	190	50	12	14	490	240	292	520	260	355	39
CM 32-160 A	32	50	80	132	160	100	70	240	190	50	12	14	490	240	292	520	260	355	42
CM 32-200 C	32	50	80	160	180	100	70	240	190	50	12	14	505	268	340	530	305	400	51.5
CM 32-200 B1	32	50	80	160	180	100	70	240	190	50	12	14	520	268	340	615	310	460	61
CM 32-200 B	32	50	80	160	180	100	70	240	190	50	12	14	565	268	340	615	310	460	63
CM 32-200 A1	32	50	80	160	180	100	70	240	190	50	12	14	520	268	340	615	310	460	67
CM 32-200 A	32	50	80	160	180	100	70	240	190	50	12	14	565	268	340	615	310	460	69
CM 32-250 C	32	50	100	180	225	125	95	320	250	65	12	14	625	305	405	665	335	535	83
CM 32-250 B	32	50	100	180	225	125	95	320	250	65	14	14	625	305	405	665	335	535	90
CM 32-250 A1	32	50	100	180	225	125	95	320	250	65	14	14	625	305	405	665	335	535	95
CM 32-250 A	32	50	100	180	225	125	95	320	250	65	14	14	695	305	405	735	335	535	120
CM 40-125 C	40	65	80	112	140	100	70	210	160	50	12	14	495	220	252	520	260	355	36
CM 40-125 B	40	65	80	112	140	100	70	210	160	50	12	14	495	220	252	520	260	355	37
CM 40-125 A	40	65	80	112	140	100	70	210	160	50	12	14	495	220	252	250	260	355	40
CM 40-160 B	40	65	80	132	160	100	70	240	190	50	12	14	500	245	292	520	260	355	47
CM 40-160 A	40	65	80	132	160	100	70	240	190	50	15	14	500	245	292	520	260	355	50
CM 40-200 B	40	65	100	160	180	100	70	265	212	50	15	14	590	273	340	615	310	460	65
CM 40-200 A	40	65	100	160	180	100	70	265	212	50	15	14	590	273	340	615	310	460	71
CM 40-250 C	40	65	100	180	225	125	95	320	250	65	15	14	630	322	405	665	335	535	84
CM 40-250 B	40	65	100	180	225	125	95	320	250	65	15	14	630	322	405	665	335	535	91
CM 40-250 A1	40	65	100	180	225	125	95	320	250	65	15	14	630	322	405	665	335	535	96
CM 40-250 A	40	65	100	180	225	125	95	320	250	65	15	14	700	322	405	735	335	535	121
CM 50-125 B	50	65	100	132	160	100	70	240	190	50	12	14	525	250	292	520	260	355	47
CM 50-125 A	50	65	100	132	160	100	70	240	190	50	12	14	525	250	292	520	260	355	50
CM 50-160 B1	50	65	100	150	180	100	70	265	212	50	12	14	545	270	340	615	310	460	63
CM 50-160 B	50	65	100	150	180	100	70	265	212	50	12	14	590	270	340	615	310	460	65
CM 50-160 A1	50	65	100	150	180	100	70	265	212	50	12	14	545	270	340	615	310	460	69
CM 50-160 A	50	65	100	150	180	100	70	265	212	50	12	14	590	270	340	615	310	460	71
CM 50-200 C	50	65	100	160	200	100	70	265	212	50	12	14	635	290	360	665	335	535	82
CM 50-200 B	50	65	100	160	200	100	70	265	212	50	12	14	635	290	360	665	335	535	89
CM 50-200 A1	50	65	100	160	200	100	70	265	212	50	12	14	635	290	360	665	335	535	94
CM 50-200 A	50	65	100	160	200	100	70	265	212	50	12	14	705	290	360	735	335	535	122
CM 50-250 C	50	65	100	180	225	125	95	320	250	65	14	14	705	332	405	735	355	535	125
CM 50-250 B	50	65	100	180	225	125	95	320	250	65	14	14	750	332	405	815	355	535	140
CM 50-250 A	50	65	100	180	225	125	95	320	250	65	14	14	750	332	405	815	355	535	149
CM 65-125 B1	65	80	100	160	180	125	95	280	212	65	14	14	560	280	340	615	310	460	62
CM 65-125 B	65	80	100	160	180	125	95	280	212	65	14	14	605	280	340	615	310	460	64
CM 65-125 A1	65	80	100	160	180	125	95	280	212	65	14	14	560	280	340	615	310	460	68
CM 65-125 A	65	80	100	160	180	125	95	280	212	65	14	14	605	280	340	615	310	460	70
CM 65-160 C	65	80	100	160	200	125	95	280	212	65	14	14	635	290	360	665	335	535	84
CM 65-160 B	65	80	100	160	200	125	95	280	212	65	14	14	635	290	360	665	335	535	90
CM 65-160 A1	65	80	100	160	200	125	95	280	212	65	14	14	635	290	360	665	355	535	95
CM 65-160 A	65	80	100	160	200	125	95	280	212	65	14	14	705	290	360	735	355	535	120
CM 65-200 C1	65	80	100	180	225	125	95	320	250	65	14	14	675	330	405	735	355	535	92
CM 65-200 C	65	80	100	180	225	125	95	320	250	65	14	14	705	330	405	735	355	535	122
CM 65-200 B	65	80	100	180	225	125	95	320	250	65	14	14	750	330	405	815	355	535	138
CM 65-200 A	65	80	100	180	225	125	95	320	250	65	14	14	750	330	405	815	355	535	148
CM 65-250 B	65	80	100	200	250	160	120	360	280	80	16	19	850	370	450	850	380	490	239
CM 65-250 A	65	80	100	200	250	160	120	360	280	80	16	19	850	370	450	850	380	490	253
CM 80-160 E	80	100	125	180	225	125	95	320	250	65	14	14	665	330	405	665	335	535	92
CM 80-160 D	80	100	125	180	225	125	95	320	250	65	14	14	665	330	405	665	335	535	98.5
CM 80-160 C1	80	100	125	180	225	125	95	320	250	65	14	14	665	330	405	665	335	535	104
CM 80-160 C	80	100	125	180	225	125	95	320	250	65	14	14	735	330	405	735	335	535	1299
CM 80-160 B	80	100	125	180	225	125	95	320	250	65	14	14	780	330	405	815	335	535	143
CM 80-160 A	80	100	125	180	225	125	95	320	250	65	14	14	780	330	405	815	335	535	152
CM 80-200 B	80	100	125	180	225	125	95	345	280	65	16	14	870	355	405	850	380	490	233
CM 80-200 A	80	100	125	180	225	125	95	345	280	65	16	14	870	355	405	850	380	490	247

CHARACTERISTICS

USES - Medium delivery centrifugal pumps for small and medium agricultural applications. Open rotor which allows small solid items to pass through (Ø max 10 mm.).

CONSTRUCTION FEATURES -Cast iron pump casing with threaded openings; cast iron motor bracket; impeller in Noryl® or in brass; ceramic - graphite mechanical seal; motor shaft in AISI 416 steel; world leading brand ball bearings; liquid temperature range 0 - 90 °C (0 - 50 °C if impeller in Noryl®); max. operating pressure 6 bar.

MOTOR - 2 pole electric induction motor for continuous operations; stator made with low-loss laminated electric sheet steel; insulation Class F; IP 44 protection level; thermal protection for single-phase models; the user is responsible for supplying protection for the three-phase models.

ON REQUEST - Other operating voltages and frequencies; special mechanical seal; special liquids.

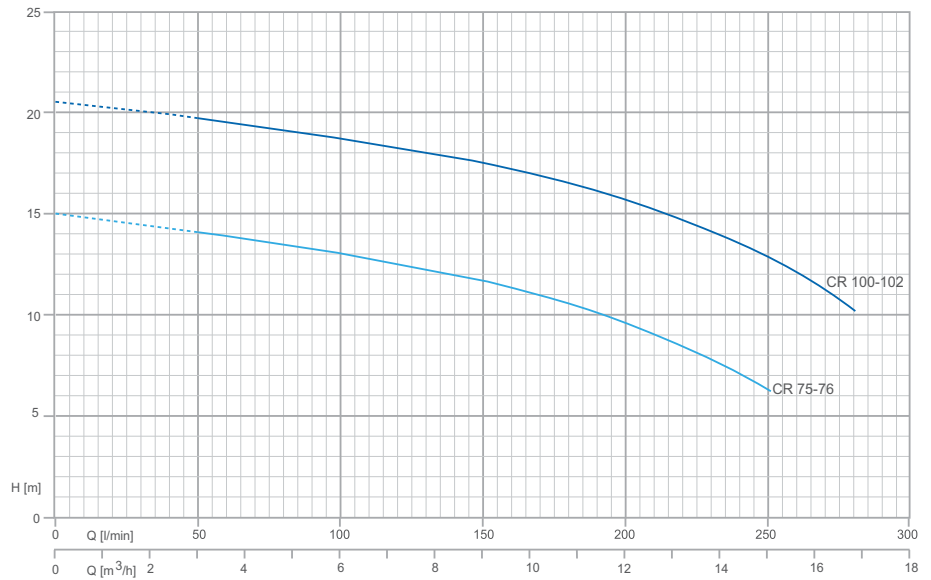

Dimensions

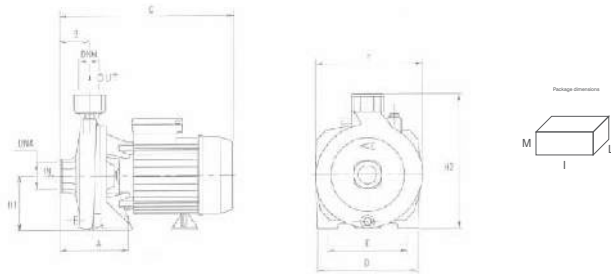

Technical data

TYPE		P2P1		(kW)		AMPERE		Q (m³/h - l/min)						
1~	3~	(HP)	(kW)	1~3~		1~3~		2.4	4.8	7.2	9.6	12	14.4	16.8
								40	80	120	160	200	240	280
230 V - 50 Hz	230 / 400 V - 50 Hz					1x230V 50Hz	3x400V 50Hz	H (m)						
CR 75	CRT 75	0.8	0.59	0.73	0.83	3.4	1.5	14.5	13.5	12.5	11.3	9.5	7	-
CR 100	CRT 100	1	0.74	1.14	1.2	5.3	2.4	20	19.2	18.5	17.3	15.5	13.5	10.5
CR 76	CRT 76	0.8	0.59	0.73	0.83	3.4	1.5	14.5	13.5	12.5	11.3	9.5	7	-
CR 102	CRT 102	1	0.74	1.14	1.2	5.3	2.4	20	19.2	18.5	17.3	15.5	13.5	10.5

TYPE	DIMENSIONS (mm)										Kg			
	A	B	C	D	E	F	H1	H2	DN	DNm	I	L	M	
CR 75	120	45	308	155	115	170	97	222	1"1/2 G	1"1/4 G	325	200	265	12.2
CR 100	120	45	308	155	115	170	97	222	1"1/2 G	1"1/4 G	325	200	265	13.5
CR 76	120	45	308	155	115	170	97	222	1"1/2 G	1"1/2 G	325	200	265	12.2
CR 102	120	45	308	155	115	170	97	222	1"1/2 G	1"1/2 G	325	200	265	13.5

CHARACTERISTICS

USES - Centrifugal pumps that combine medium head with medium-high delivery; ideal for irrigation and in applications where quiet operations are requested and only slight pressure change as the delivery. Volume vary.

CONSTRUCTION FEATURES - Cast iron pump casing with threaded openings; cast iron motor bracket; Impeller in brass for models CH150, CH200 CH300; in cast iron for models CH 350+550; ceramic - graphite mechanical seal; motor shaft in AISI 303 steel on the hydraulic side; world leading brand ball bearings; liquid temperature range 0 - 90 °C; max. operating pressure 6 bar.

MOTOR - 2 pole electric induction motor for continuous operations; stator made with low-loss laminated electric sheet steel; insulation Class F; IP 44 protection level; the user is responsible for supplying protection.

ON REQUEST - Other operating voltages and frequencies; special mechanical seal; special liquids.

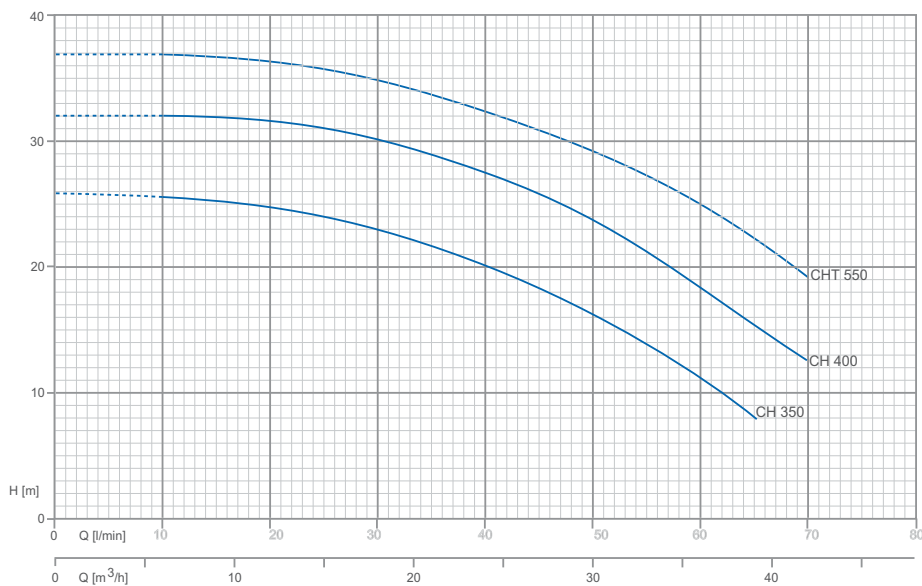

Dimensions

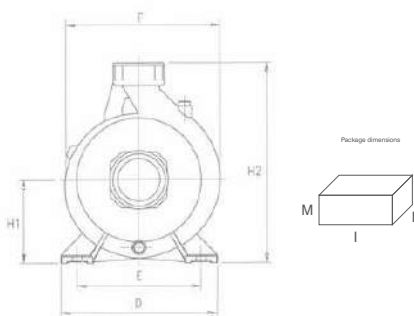
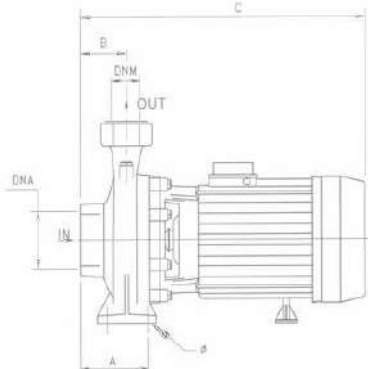

Technical data

1~	3~	P2P1		(kW)				AMPERE		Q (m³/h - l/min)						
								1~3~		6	12	18	24	30	36	42
230 V - 50 Hz	230 / 400 V - 50 Hz	(HP)	(kW)	1~3~		1x230V 50Hz	3x400V 50Hz	H (m)								
CH 350	CHT 350	3	2.2	2.95	2.84	13.5	5.1	26	25	23	20	16	10.5	-		
CH 400	CHT 400	4	3	4.60	4.20	20.5	7.6	31.8	31.6	29.7	27.8	23	18.6	12.3		
-	CHT 550	5.5	4	-	5.10	-	10	37	37	35.5	33	29.4	25	19		

TYPE	DIMENSIONS (mm)											Kg			
	A	B	C	D	E	F	Ø	H1	H2	DNA	DNM	I	L	M	
CH 350	105	70	425	240	190	240	14	126	306	3" G	2" G	460	270	360	34.5
CHT 350	105	70	385	240	190	240	14	126	306	3" G	2" G	400	270	360	28.5
CH 400	105	70	445	240	190	240	14	126	306	3" G	2" G	460	270	360	38.7
CHT 400	105	70	425	240	190	240	14	126	306	3" G	2" G	460	270	360	33.2
CHT 550	105	70	445	240	190	240	14	126	306	3" G	2" G	460	270	360	38.7

CHARACTERISTICS

USES - Single impeller centrifugal pumps, medium sliding high delivery with 2", 3" and 4" delivery openings; mainly used in agriculture and applications requiring high capacities delivery.

CONSTRUCTION FEATURES -Cast iron pump casing with threaded openings; cast iron motor bracket; cast iron impeller, and brass impeller for models CSB100 and CSB150 ; ceramic - graphite mechanical seal; motor shaft in AISI 416 steel (CS 75-100), in AISI 303 the hydraulic side in other models; world leading brand ball bearings; liquid temperature range 0 - 90 °C; max. operating pressure 6 bar.

MOTOR - 2 pole electric induction motor for continuous operations; stator made with low-loss laminated electric sheet steel; insulation Class F; IP 44 protection level; thermal protection for single-phase models (excluding models CS200, CS300 and CS450); the user is responsible for supplying protection for the three-phase models.

ON REQUEST - Other operating voltages and frequencies; special mechanical seal; special liquids.



CS 75/2

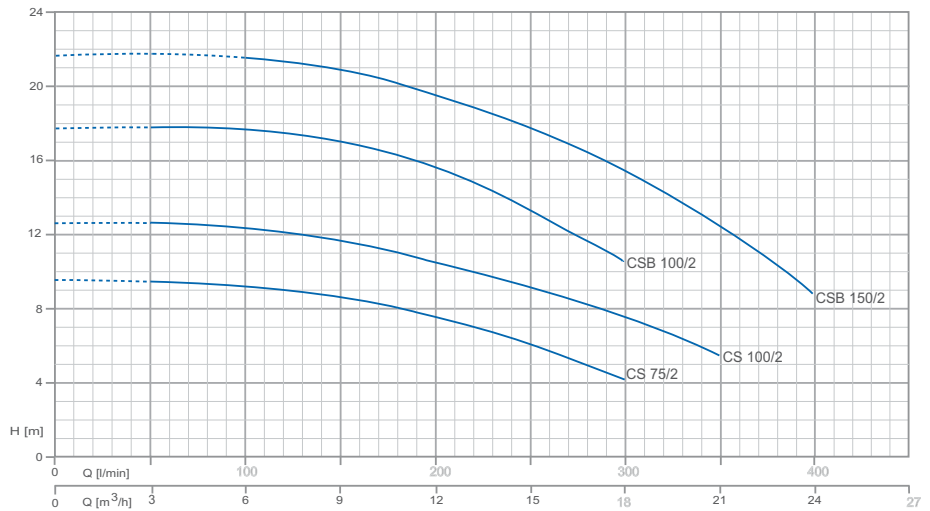

Dimensions

TYPE		P2P1		AMPERE				Q (m ³ /h - l/min)								
1~	3~	(HP)	(kW)	(kW)		1~3~		0	3	6	9	12	15	18	21	24
				1~3~	1x230V 50Hz	3x400V 50Hz	0	50	100	150	200	250	300	350	400	
CS 75/2	CST 75/2	0.8	0.59	0.63	0.7	2.9	1.3	9.5	9.4	9.2	8.5	7.3	6	4.2	-	-
CS 100/2	CST 100/2	1	0.74	0.92	1.05	4.3	2.3	12.6	12.5	12.3	11.5	10.3	9.3	7.5	5.5	-
CSB 100/2	-	1	0.74	1.23	-	6.0	-	17.5	17.5	17.5	16.7	15.2	13.2	10.5	-	-
CSB 150/2	CSBT 150/2	1.5	1.1	1.78	1.65	8.5	3.0	21.5	21.5	21.5	20.6	19.2	17.5	15.3	12.3	8.8



CST 400/3

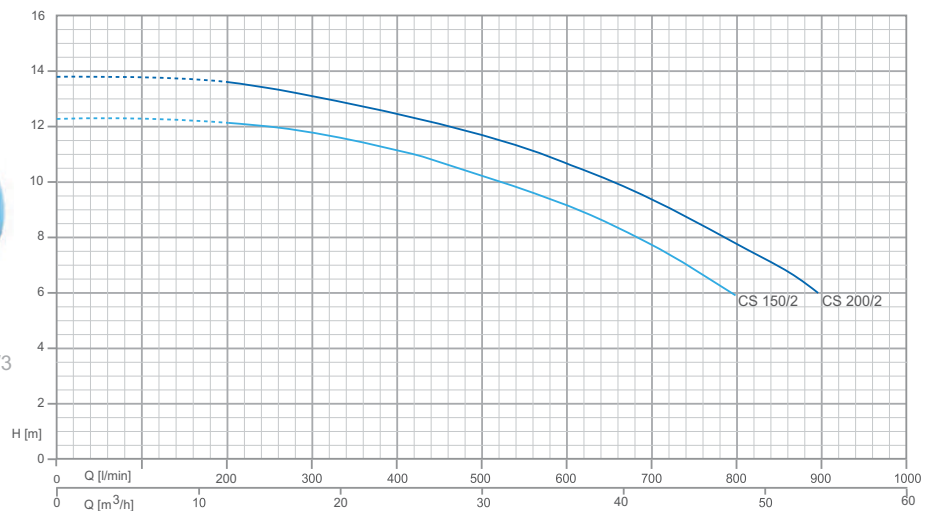

Dimensions

TYPE		P2P1		AMPERE				Q (m ³ /h - l/min)									
1~	3~	(HP)	(kW)	(kW)		1~3~		0	6	12	18	24	30	36	42	48	54
				1~3~	1x230V 50Hz	3x400V 50Hz	0	100	200	300	400	500	600	700	800	900	
CS 150/2	CST 150/2	1.5	1.1	1.85	1.8	8.8	3.3	12.3	12.3	12.2	11.8	11	10.2	9.1	7.7	6	-
CS 200/2	CST 200/2	2.2	1.65	2.1	2.1	10.0	3.9	13.8	13.8	13.6	13.1	12.4	11.6	10.6	9.4	7.8	6

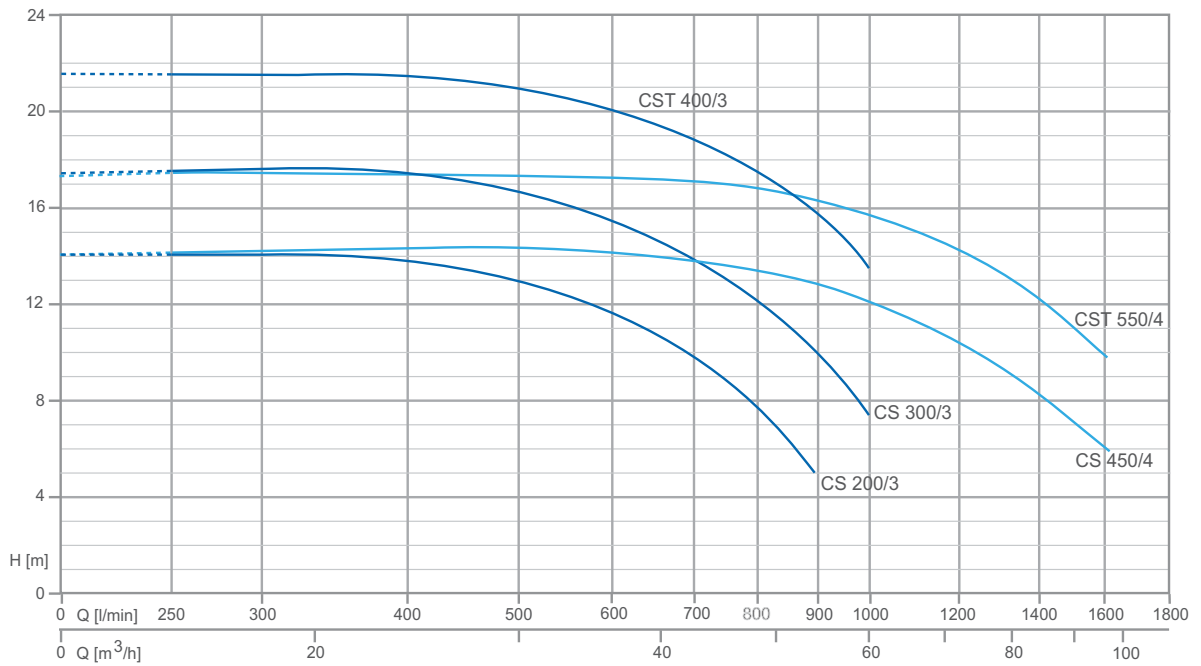

Dimensions

TYPE		P2P1		(kW)		AMPERE		Q (m³/h - l/min)								
1~	3~	(HP)	(kW)	1~3~		1~3~		0	15	24	36	48	60	72	84	96
230 V - 50 Hz	230 / 400 V - 50 Hz					1x230V 50Hz	3x400V 50Hz	0	250	400	600	800	1000	1200	1400	1600
								H (m)								
CS 200/3	CST 200/3	2.2	1.65	2.35	2.15	11.0	3.6	14.2	14.2	13.8	11.7	7.8	-	-	-	-
CS 300/3	CST 300/3	3	2.2	3.3	2.9	15.0	4.9	17.5	17.5	17.2	15.3	12.3	7.5	-	-	-
-	CST 400/3	4	3	-	4	-	6.7	21.5	21.5	21.4	19.9	17.7	13.5	-	-	-
CS 450/4	CST 450/4	4	3	3.7	3.6	18.0	6.2	13.5	-	-	14.1	13.4	12.1	10.3	8.3	6.1
-	CST 550/4	5.5	4	-	5.05	-	8.8	17	-	-	17.3	16.8	15.7	14.4	12.2	10

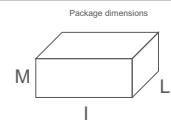
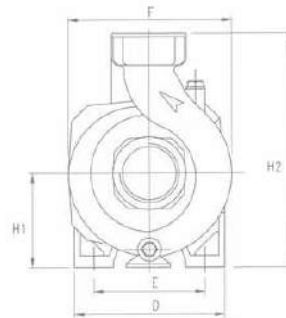
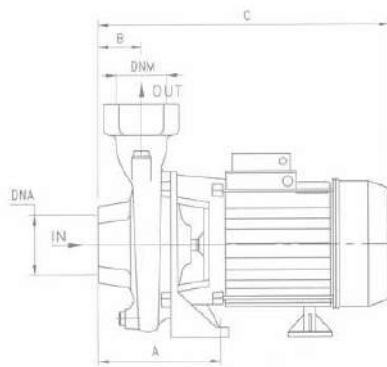

Technical data

TYPE	DIMENSIONS (mm)									Package dimensions			Kg	
	A	B	C	D	E	F	H1	H2	DNM	DNA	I	LM		
CS 75/2	127	45	315	155	115	178	97	247	2"G	2"G	340	195	280	14.2
CS 100/2	127	45	315	155	115	178	97	247	2"G	2"G	340	195	280	15.5
CS 150/2	150	53	370	180	140	218	115	285	2"G	2"G	390	230	325	23.3
CS 200/2	150	53	370	180	140	218	115	285	2"G	2"G	390	230	325	24.3
CSB 100/2	130	70	365	180	130	195	90	240	2"G	2"G	390	230	325	18.2
CSB 150/2	130	70	365	180	130	195	90	240	2"G	2"G	390	230	325	19.1
CS 200/3	160	80	455	200	140	225	112	292	3"G	3"G	480	245	330	28.3
CS 300/3	160	80	455	200	140	225	112	292	3"G	3"G	480	245	330	31.5
CST 400/3	160	80	455	200	140	225	112	292	3"G	3"G	480	245	330	31.6
CST 450/4	165	85	480	220	160	250	130	330	4"G	4"G	510	275	365	41.1
CST 550/4	165	85	480	220	160	250	130	330	4"G	4"G	510	275	365	41.1

CHARACTERISTICS

USES - Two impeller centrifugal pumps for constructing pressurisation systems for civil and industrial plant; the two counter-posed impellers guarantee high head with good delivery.

CONSTRUCTION FEATURES - Cast iron pump casing with threaded openings; cast iron motor bracket; impeller in brass and Noryl® (mod. CB100 + 751, CBT 900), brass impeller CBT 800, 1000 + 1500; ceramic - graphite mechanical seal; motor shaft in AISI 416 steel CB 100, in 303 the hydraulic side in other models; world leading brand ball bearings; Liquid temperature range 0 - 90 °C (0 - 50 °C if impeller in Noryl®); max. operating pressure: 6 bar for CB100, 10 bar up to CBT 751 and CBT 900, 11 bar for larger models.

MOTOR - 2 pole electric induction motor for continuous operations; stator made with low-loss laminated electric sheet steel; insulation Class F; IP 44 protection level; thermal protection for single-phase models (excluding models CB400 and CB600); the user is responsible for supplying protection for the three-phase models.

ON REQUEST - Other operating voltages and frequencies; special mechanical seal; special liquids.

Dimensions

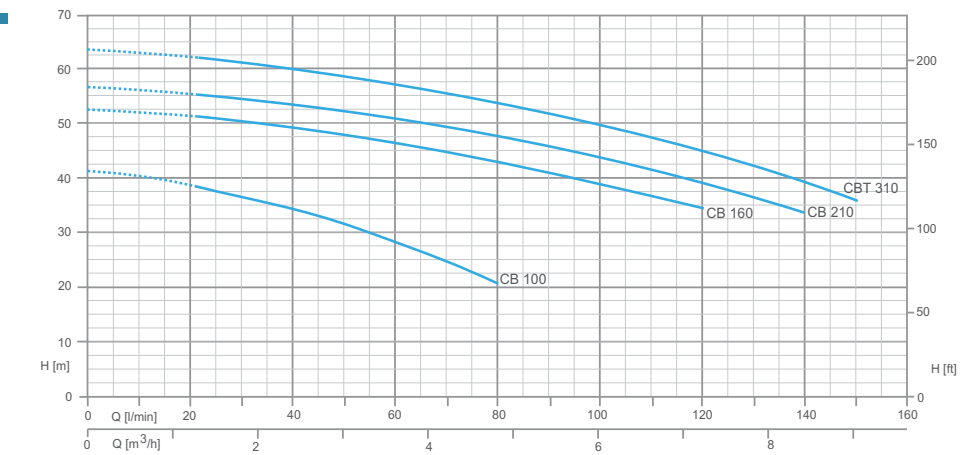

TYPE		P2		P1 (kW)		AMPERE		Q (m³/h - l/min)											
1~	3~	(HP)	(kW)	1-3~		1-3~		H (m)											
230 V - 50 Hz	230 / 400 V - 50 Hz					1x230V 50Hz	3x400V 50Hz	0	0.6	1.2	1.8	2.4	3.6	4.8	6	7.2	8.4	9	
								0	10	20	30	40	60	80	100	120	140	150	
CB 100	CBT 100	1	0.74	1.17	1.15	5.4	2.4	42	40.8	39.4	37.4	34.7	29.2	21	-	-	-	-	
CB 160	CBT 160	1.5	1.1	2.30	2.20	10.2	4.1	53	52.5	52	51	50	46.9	43.3	39.7	35	-	-	
CB 210	CBT 210	2	1.5	2.60	2.45	11.5	4.8	57.3	56.9	56	55.1	54	51.5	48.4	44.4	39.5	34	-	
-	CBT 310	3	2.2	-	2.80	-	5.2	64	63.5	63	61.9	60.6	57.7	54.1	50	45.4	39.4	36	

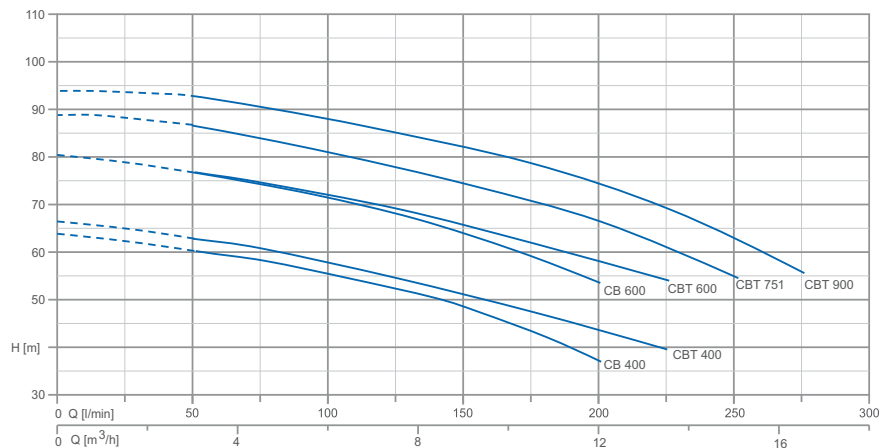

TYPE		P2		P1 (kW)		AMPERE		Q (m³/h - l/min)																	
1~	3~	(HP)	(kW)	1-3~		1-3~		H (m)																	
230 V - 50 Hz	230 / 400 V - 50 Hz					1x230V 50Hz	3x400V 50Hz	0	1.5	3	4.5	6	7.5	9	10.5	12	13.5	15	16.5						
								0	25	50	75	100	125	150	175	200	225	250	275						
CB 400	-	4	3	4.3	-	19	-	64.4	62.7	60.8	58.3	55.6	52.6	48.7	43.5	37.9	-	-	-						
-	CBT 400	4	3	-	4.6	-	7.9	66.9	65.2	63.3	61	58.4	55.2	51.5	47.8	44.3	40.1	-	-						
CB 600	-	5.5	4	5.7	-	26	-	80.4	79.1	77.1	74.5	71.8	68.4	64	59.2	54.1	-	-	-						
-	CBT 600	5.5	4	-	5.65	-	9.8	80.4	79.1	77.1	75	72.2	69.4	66	62.4	58.6	54.5	-	-						
-	CBT 751	7.5	5.5	-	6.8	-	11.6	89.5	88.3	86.7	84.1	81.3	78.3	74.7	71.1	66.9	61.3	55	-						
-	CBT 900	9	6.6	-	7.6	-	13.2	94.2	93.8	92.8	91.2	88.7	85.7	82.5	79.1	75	69.4	64.4	56						

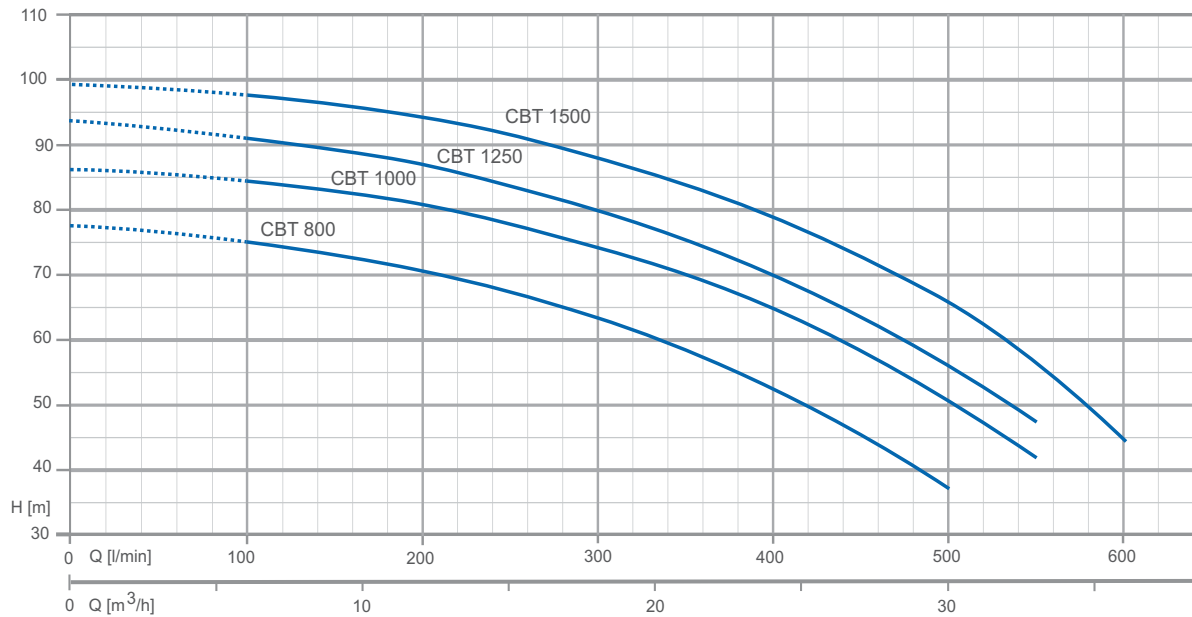

TYPE	P2		P1 (kW)	AMPERE 3~	Q (m ³ /h - l/min)							
					0	6	12	18	24	30	33	36
3~			3~	3~	0	100	200	300	400	500	550	600
400 / 690 V - 50 Hz	(HP)	(kW)	3~	3x400V 50Hz	H (m)							
CBT 800	7.5	5.5	8.5	15.0	77	74.6	70.5	62.8	51.6	36	-	-
CBT 1000	10	7.5	10.35	17.2	86.4	84.8	80.7	74.3	64	50.2	40.4	-
CBT 1250	12.5	9.2	11.1	18.9	93.6	91	86.3	79.7	68.5	55.2	46	-
CBT 1500	15	11	12.1	20.4	98.7	97.6	94.2	87.6	78.2	65.6	57.5	40.9

Dimensions

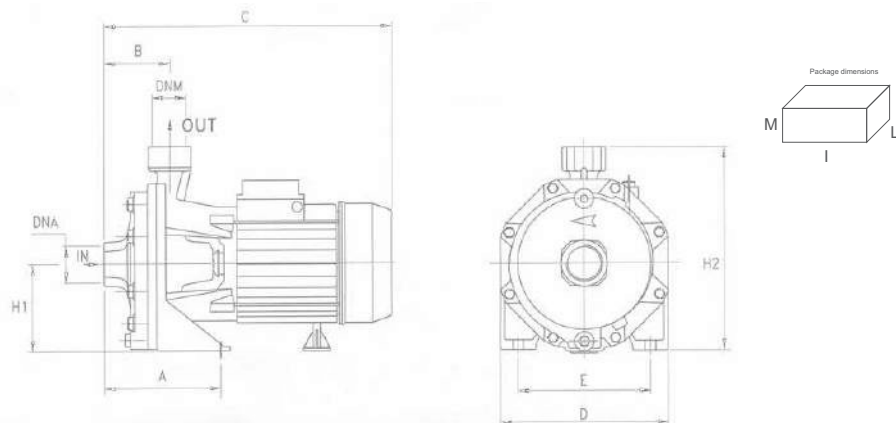

TYPE	DIMENSIONS (mm)												Kg
	A	B	C	D	E	H1	H2	DNA	DNM	I	L	M	
CB 100	122	72	328	180	140	98	228	1" G	1" G	350	195	265	15.3
CB 160	115	82	385	210	170	110	265	1" 1/4 G	1" G	405	225	295	24.7
CB 210	115	82	385	210	170	110	265	1" 1/4 G	1" G	405	225	295	25.6
CB 310	115	82	385	210	170	110	265	1" 1/4 G	1" G	405	225	295	25.6
CB 400	145	95.5	463	266	212	135	305	1" 1/2 G	1" 1/4 G	500	275	350	41
CBT 600	145	95.5	463	266	212	135	305	1" 1/2 G	1" 1/4 G	500	275	350	44.8
CBT 751	145	95.5	480	266	212	135	305	1" 1/2 G	1" 1/4 G	500	275	350	50.5
CBT 900	145	95.5	480	266	212	135	305	1" 1/2 G	1" 1/4 G	500	275	350	55
CBT 800	190	120	605	275	210	150	330	2" G	1" 1/4 G	640	310	370	70.5
CBT 1000	190	120	605	275	210	150	330	2" G	1" 1/4 G	640	310	370	77
CBT 1250	190	120	645	275	210	150	330	2" G	1" 1/4 G	640	310	370	85
CBT 1500	190	120	645	275	210	150	330	2" G	1" 1/4 G	640	310	370	92

CHARACTERISTICS

USES - Two impellers compact centrifugal pumps for constructing pressurisation systems irrigation systems, for civil and industrial plant: guarantee good ratio between pressure and delivery.

CONSTRUCTION FEATURES - Cast iron pump casing with threaded openings; cast iron motor bracket; impeller in Noryl® or in brass; ceramic - graphite mechanical seal; motor shaft in AISI 303 steel on the hydraulic side; world leading brand ball bearings; liquid temperature range 0 - 90°C (0 - 50°C if impeller in Noryl®); max. operating pressure 8 bar.

MOTOR - 2 pole electric induction motor for continuous operations; stator made with low-loss laminated electric sheet steel; insulation Class F; IP 44 protection level; thermal protection for single-phase models; the user is responsible for supplying protection for the three-phase models.

ON REQUEST - Other operating voltages and frequencies; special mechanical seal; special liquids.

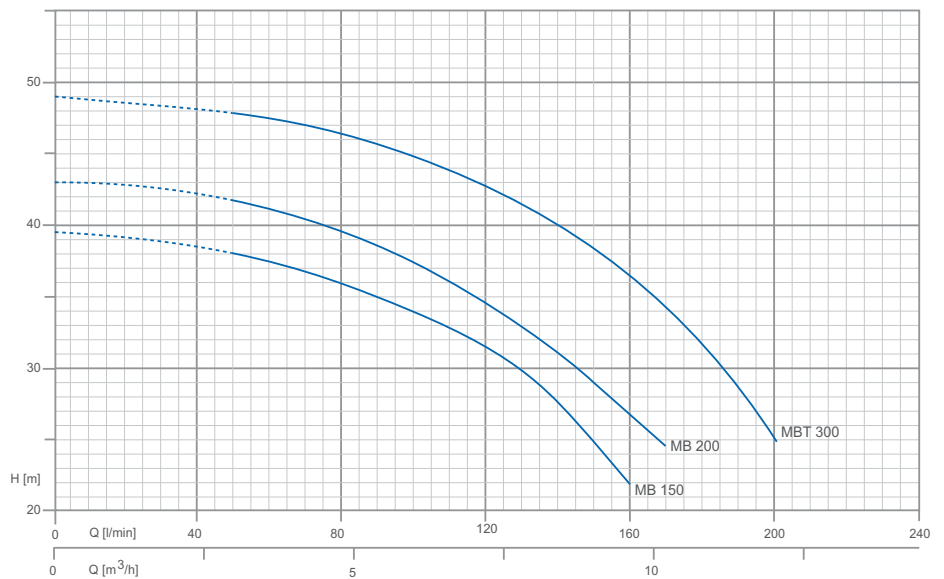

Dimensions

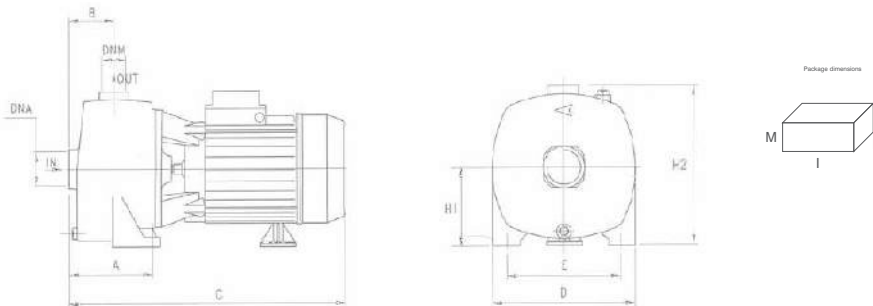

Technical data

TYPE		P2P1		(kW)				AMPERE							
1~	3~	(HP)	(kW)	1~3~		1~3~		0	2.4	4.8	7.2	9.6	12		
230 V - 50 Hz	230 / 400 V - 50 Hz			1~3~		1x230V 50Hz	3x400V 50Hz	0	40	80	120	160	200		
MB 150	MBT 150	1.5	1.1	1.60	1.55	7.7	2.9	39.5	38.5	36	30.8	22	-		
MB 200	MBT 200	2.2	1.65	2	1.90	9.5	3.6	43	42.1	39.5	34.5	26	-		
MB 300	MBT 300	3	2.2	-	2.60	-	4.8	49	48.4	47.2	43.6	36.5	25		

TYPE	DIMENSIONS (mm)											Kg	
	A	B	C	D	E	H1	H2	DNA	DNM	I	L		M
MB 150	108	73	385	205	165	115	242	1"1/2G	1"1/4G	405	225	295	21.2
MB 200	108	73	385	205	165	115	242	1"1/2G	1"1/4G	405	225	295	21.7
MB 300	108	73	385	205	165	115	242	1"1/2G	1"1/4G	405	225	295	21.7

CHARACTERISTICS

USES - Stainless steel multistage horizontal pumps. Pumping of clean non-loaded fluids in the domestic, agricultural and industrial sectors; pressurizing systems; irrigation; drinking and glycol water; water treatment; food industry; heating and air conditioning; washing system.

ADVANTAGES - Closed coupled and compact; silent; excellent efficiency that allows a reduction of running cost and power consumption; economical; over-dimensioned bearing for longer life of the machines: intermediate shaft guiding stage for concentricity of rotation

CONSTRUCTION FEATURES - Capacity: up to 26 m³/h; total Head: up to 78 m.; maximum working pressure: 8 bar (9 bar with 7 impellers); maximum liquid temperature: from -15 up to + 110 °C; ambient temperature: max 40 °C.

MOTOR - 2 pole induction Motor; single phase 230V - 50Hz with thermal protector up to P2= 1,85 Kw; three phase 230-400V - 50 Hz; insulation class F; protection degree IP 44.

MATERIALS - Pump body, impellers, diffusers, mechanical seal disc holder: chromo-nickel steel AISI 304; pump shaft: AISI 304 chromo-nickel steel; motor bracket: aluminum alloy; mechanical seal: ceramic-graphite up to 6 stages - graphite-silicon carbide from 7 stages; intermediate shaft guiding stage bush: ceramic-tungsten carbide; pump body gasket: EPDM.



ULTRA 18S



ULTRA 5S



ULTRA 9S



ULTRA 7S



ULTRA 3S

U 5 S - 120 / 4 T

- Трёхфазные - Three-phase
- Количество рабочих колес - no. of impellers
- Номинальная мощность HPx100 - Nominal Power HPx100
- Нержавеющая сталь с гидравлической стороны - Stainless-steel hydraulic
- Номинальная пропускная способность m³/h - Nominal flow-rate m³/h
- Модель - Type **ULTRA**

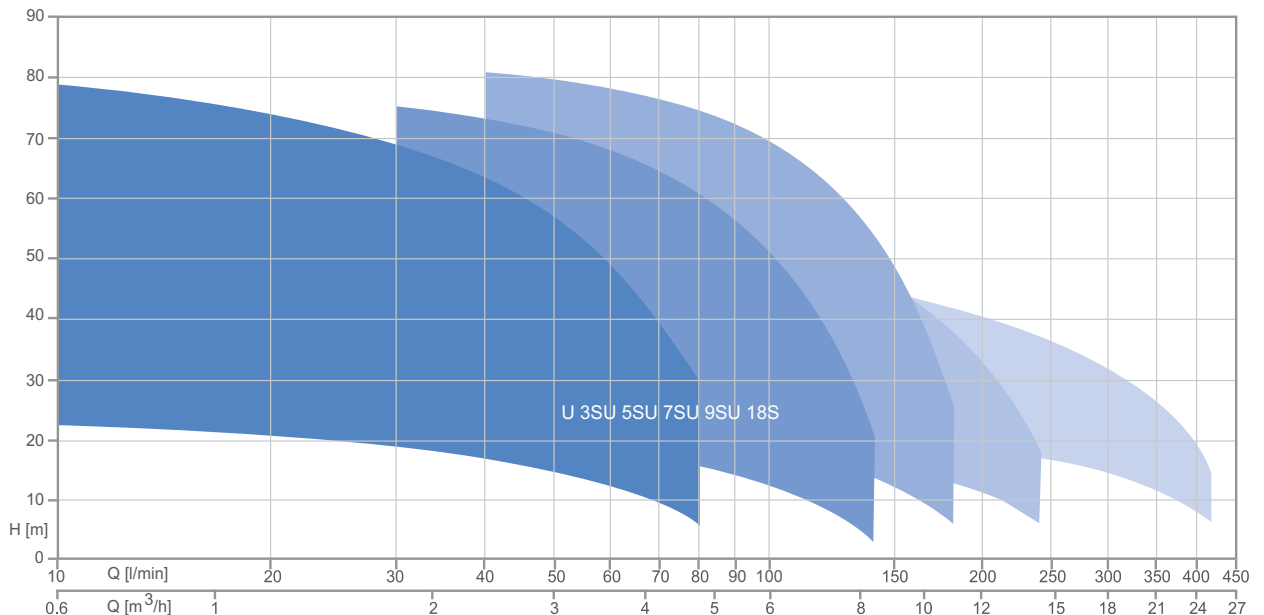

ULTRA 3S

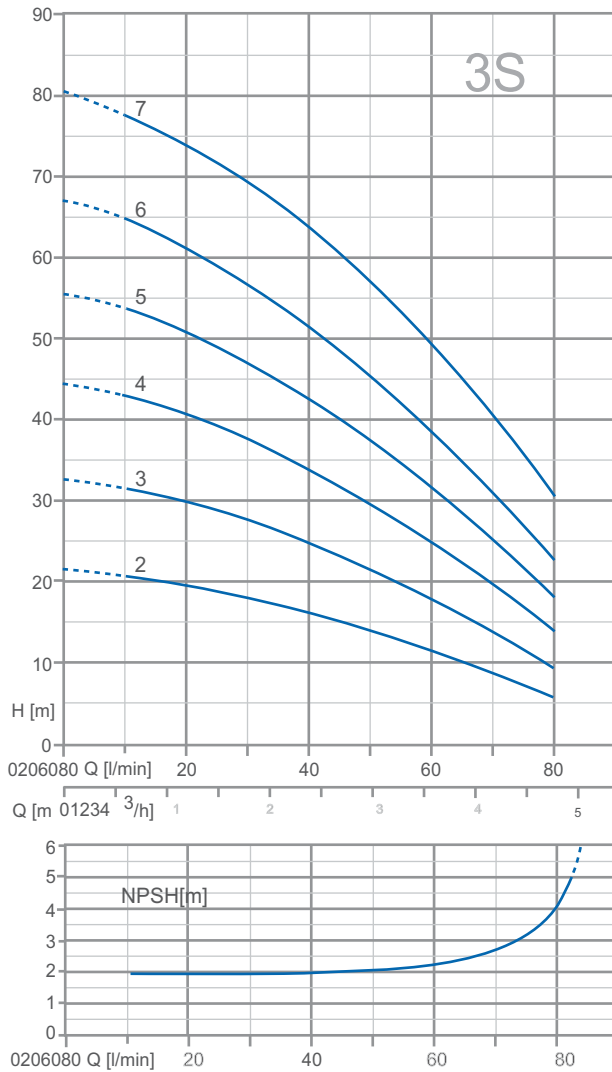

ULTRA 5S

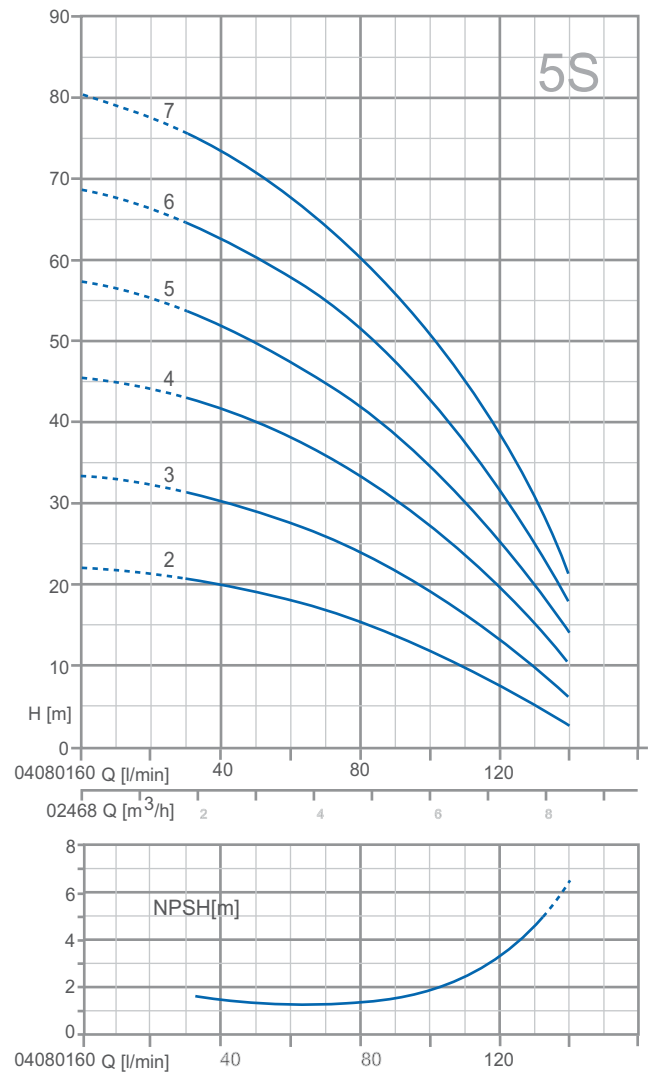

Technical data

TYPE		P2P1		(kW)		AMPERE		Q (m³/h - l/min)						
1~	3~					1-3~		0	0.6	1.2	1.8	2.4	3.6	4.8
						1x230V 50Hz	3x400V 50Hz	0	10	20	30	40	60	80
230 V - 50 Hz	230 / 400 V - 50 Hz	(HP)	(kW)	1~3~				H (m)						
U 3S-50/2	U 3S-50/2 T	0.5	0.37	0.42	0.41	1.8	0.9	21.7	20.9	19.3	17.8	15.9	11.4	5.8
U 3S-70/3	U 3S-70/3 T	0.7	0.51	0.61	0.58	2.7	1.1	32.7	31.3	29.2	26.7	23.9	17.2	9
U 3S-90/4	U 3S-90/4 T	0.9	0.66	0.82	0.8	3.6	1.7	44.3	42.8	40	36.4	33.2	24.5	13.9
U 3S-100/5	U 3S-100/5 T	1	0.75	0.99	0.92	4.4	1.7	55.3	53.5	50.3	46.5	42.1	31.6	17.7
U 3S-120/6	U 3S-120/6 T	1.2	0.9	1.11	1.11	5.1	2.5	66.6	64.4	60.8	56	50.7	38.1	22.4
U 3S-150/7	U 3S-150/7 T	1.5	1.1	1.38	1.31	6.4	2.7	80.1	77.7	74.2	69.1	63.3	48.8	30

TYPE		P2P1		(kW)		AMPERE		Q (m³/h - l/min)							
1~	3~					1-3~		0	1.8	2.4	3.6	4.8	6	7.2	8.4
						1x230V 50Hz	3x400V 50Hz	0	30	40	60	80	100	120	140
230 V - 50 Hz	230 / 400 V - 50 Hz	(HP)	(kW)	1~3~				H (m)							
U 5S-70/2	U 5S-70/2 T	0.7	0.51	0.6	0.58	2.6	1.1	22.3	20.4	19.5	17.5	14.8	11.7	7.8	2.8
U 5S-80/3	U 5S-80/3 T	0.8	0.6	0.8	0.75	3.8	1.4	34	31.1	29.9	27	23.6	19.1	13.1	6
U 5S-120/4	U 5S-120/4 T	1.2	0.9	1.09	1.08	4.9	2.4	45.5	42.2	40.7	37.2	32.9	27.4	19.8	10.4
U 5S-150/5	U 5S-150/5 T	1.5	1.1	1.39	1.31	6.5	2.7	57.2	53.4	51.7	47.6	42.3	35.2	25.7	14
U 5S-180/6	U 5S-180/6 T	1.8	1.3	1.63	1.55	7.3	3	68.9	64.4	62.3	57.5	51.5	43.5	32.6	18.1
U 5S-200/7	U 5S-200/7 T	2	1.5	1.94	1.67	8.7	3.3	81	75.5	73	67.4	60.3	51	38.6	21

ULTRA 7S

ULTRA 9S

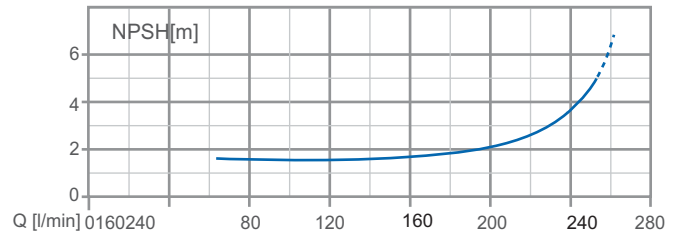
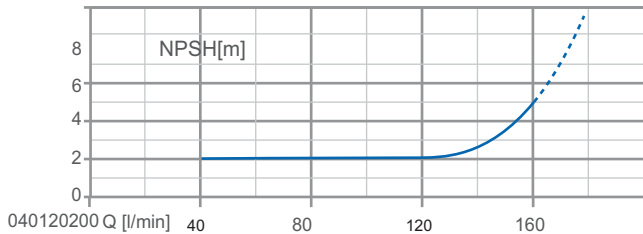
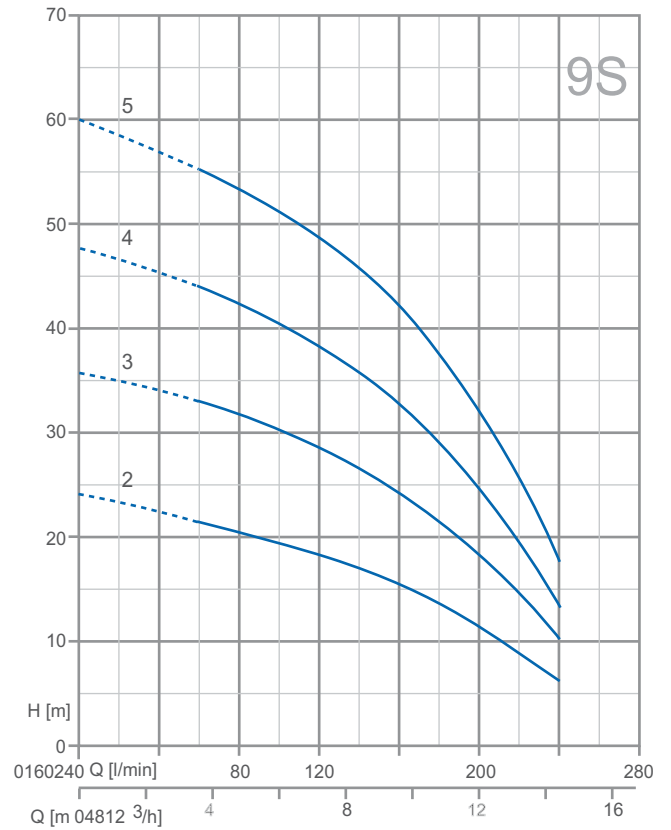
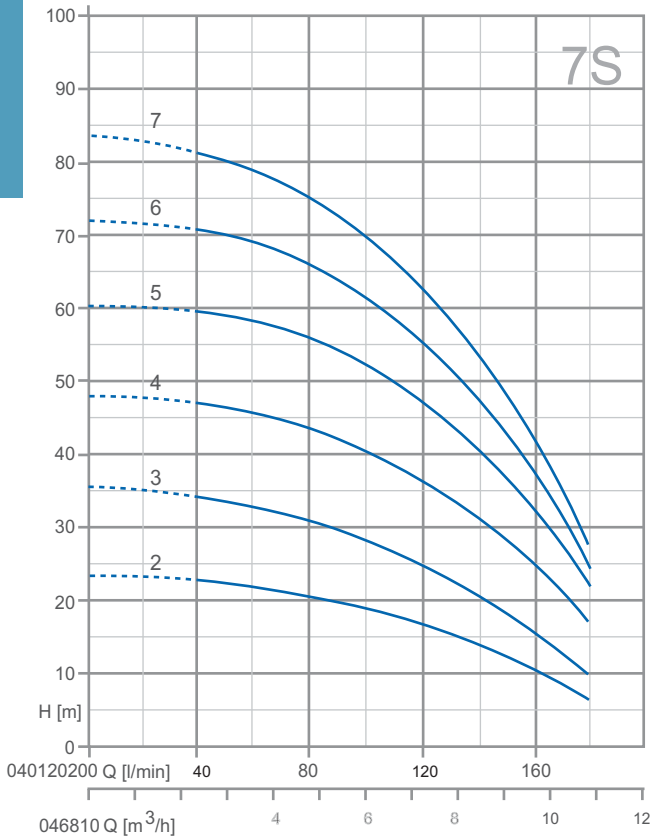

Technical data

TYPE		P2P1		(kW)		AMPERE		Q (m³/h - l/min)								
1~	3~					1-3~		0	2.4	3.6	4.8	6	7.2	8.4	9.6	10.8
								0	40	60	80	100	120	140	160	180
230 V - 50 Hz	230 / 400 V - 50 Hz	(HP)	(kW)	1-3~		1x230V 50Hz	3x400V 50Hz	H (m)								
U 7S-100/2	U 7S-100/2 T	1	0.75	0.91	0.84	4.1	1.6	23.6	22.6	21.8	20.5	18.8	16.7	13.9	10.6	6.7
U 7S-120/3	U 7S-120/3 T	1.2	0.9	1.23	1.22	5.6	2.5	35.6	33.9	32.8	31.2	28.1	24.7	20.8	15.7	10.0
U 7S-180/4	U 7S-180/4 T	1.8	1.3	1.69	1.62	7.7	3.1	48.0	46.3	45.7	43.6	40.4	36.4	31.4	25.0	17.2
U 7S-250/5	U 7S-250/5 T	2.5	1.85	2.19	2.05	10.2	4.1	60.3	59.0	58.2	55.7	52.2	47.4	41.3	33.5	22
U 7S-300/6	U 7S-300/6 T	3	2.2	2.53	2.44	11.4	4.8	72.5	70.5	69.2	66	61.5	55.7	47.8	37.8	24.7
-	U 7S-350/7 T	3.5	2.57	-	2.84	-	5.1	83.5	80.7	78.8	74.7	69.4	62.6	53.9	42.7	27.5

TYPE		P2P1		(kW)		AMPERE		Q (m³/h - l/min)										
1~	3~					1-3~		0	3.6	4.8	6	7.2	8.4	9.6	10.8	12	13.2	14.4
								0	60	80	100	120	140	160	180	200	220	240
230 V - 50 Hz	230 / 400 V - 50 Hz	(HP)	(kW)	1-3~		1x230V 50Hz	3x400V 50Hz	H (m)										
U 9S-100/2	U 9S-100/2 T	1	0.75	0.99	0.95	4.5	1.8	23.9	20.9	20	18.8	17.7	16.5	15	13.0	11	8.7	6
U 9S-150/3	U 9S-150/3 T	1.5	1.1	1.47	1.4	6.8	2.8	35.6	32.5	31.5	30	28.7	26.9	24.6	22	18.7	15	10.7
U 9S-200/4	U 9S-200/4 T	2	1.5	1.88	1.77	8.4	3.3	47.6	43.5	42.1	40.1	38.1	35.7	32.7	28.9	24.2	19	13.1
U 9S-250/5	U 9S-250/5 T	2.5	1.85	2.36	2.23	10.8	4.3	60	54.8	53	51	48.2	45.4	42	37.3	31.6	25	18

ULTRA 18S

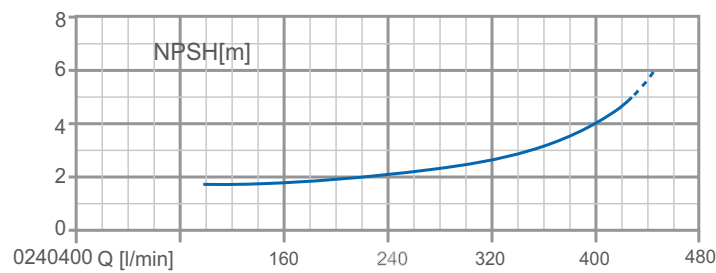
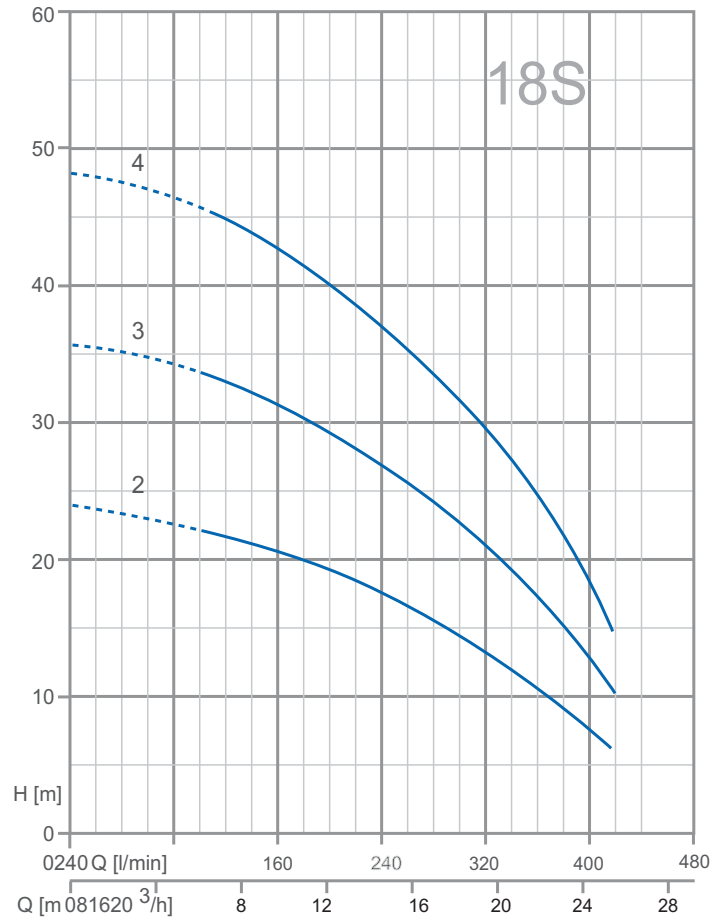

Technical data

TYPE	P2P1		(kW)	AMPERE	Q (m ³ /h - l/min)																		
					H (m)																		
3~				3~	0	6	7.2	8.4	9.6	10.8	12	13.2	14.4	15.6	16.8	18	19.2	20.4	21.6	22.8	24	25.2	
230 / 400 V - 50 Hz	(HP)	(kW)	3~	3x400V 50Hz	0	100	120	140	160	180	200	220	240	260	280	300	320	340	360	380	400	420	
U 18S-180/2 T	1.8	1.3	1.59	3	23.7	21.7	21.1	20.4	20	19.3	18.5	17.7	16.9	16	15.2	14.3	13.1	11.8	10.3	9.1	7.6	6.4	
U 18S-250/3 T	2.5	1.85	2.29	4.4	35.7	33.1	32.3	31.3	30.4	29.4	28.4	27.4	26.3	25.1	24	22.8	21.4	19.6	17.8	15.4	12.9	10.2	
U 18S-400/4 T	4	3	3.11	5.7	47.9	45	44	42.8	41.7	40.5	39.1	37.8	36.6	35.2	33.9	32.2	30.2	28	25.1	22.1	18.1	14.9	

ULTRA 3S - ULTRA 5S

Dimensions

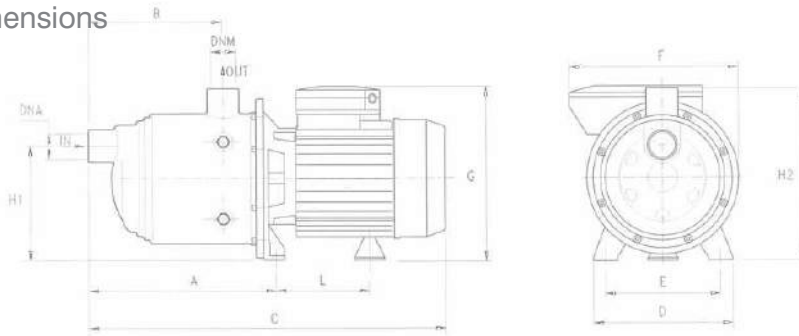

Technical data

TYPE	DIMENSIONS (mm)										Kg	DNA	DNM
	A	B	C	D	E	F	G	L	H1	H2			
U 3S-50/2	166.8	103	333	164	140	178	190	93.7	128	192	6.9	1"G	1"G
U 3S-70/3	166.8	103	333	164	140	178	190	93.7	128	192	8.0		
U 3S-90/4	190.8	127	357	164	140	178	190	93.7	128	192	9.4		
U 3S-100/5	214.8	151	404	164	140	178	203	104.7	128	192	12.0		
U 3S-120/6	238.8	175	428	164	140	178	203	104.7	128	192	12.7		
U 3S-150/7	262.8	199	483	164	140	201	211	128.2	134	198	16.1		
U 5S-70/2	166.8	103	333	164	140	178	195	93.7	128	192	7.7		
U 5S-80/3	166.8	103	357	164	140	178	203	93.7	128	192	10.3		
U 5S-120/4	190.8	127	380	164	140	178	203	104.7	128	192	12.1		
U 5S-150/5	214.8	151	436	164	140	201	211	128.2	134	198	14.9		
U 5S-180/6	238.8	175	459	164	140	201	211	128.2	134	198	16		
U 5S-200/7	262.8	199	483	164	140	201	211	128.2	134	198	18.1		

ULTRA 7S - ULTRA 9S - ULTRA 18S

Dimensions

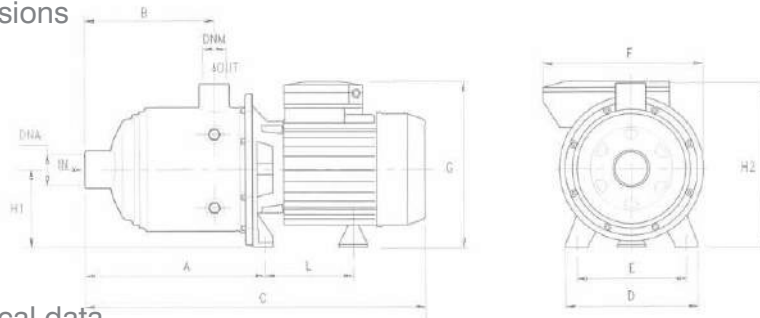

Technical data

TYPE	DIMENSIONS (mm)										Kg	DNA	DNM
	A	B	C	D	E	F	G	L	H1	H2			
U 7S-100/2	166.8	103	356	164	140	178	203	104.7	92	192	10.6	1"1/4 G	1"G
U 7S-120/3	166.8	103	356	164	140	178	203	104.7	92	192	11.6		
U 7S-180/4	190.8	127	411	164	140	201	211	128.2	98	198	15.0		
U 7S-250/5	214.8	151	436	164	140	201	211	128.2	98	198	17.3		
U 7S-300/6	238.8	175	M 503 T 459	164	140	201	M 229 T 211	M 148.2 T 128.2	M 103 T 98	M 203 T 198	20.0		
U 7S-350/7	262.8	199	527	164	140	201	229	148.2	103	203	20.7	1"1/2 G	1"1/4 G
U 9S-100/2	185.8	118	375	164	140	178	203	104.7	92	192	10.8		
U 9S-150/3	185.8	118	375	164	140	201	211	128.2	98	198	14.2		
U 9S-200/4	215.8	148	436	164	140	201	211	128.2	98	198	16.8		
U 9S-250/5	245.8	178	464	164	140	201	211	128.2	98	198	17.7		
U 18S-180/2 T	201	141	432	164	140	201	211	128.2	98	198	14.0	2"G	1"1/2 G
U 18S-250/3 T	238.5	141	432	164	140	201	211	128.2	98	198	15.8		
U 18S-400/4 T	276	178.5	514	164	140	201	229	148.2	103	203	22.6		

CHARACTERISTICS

USES - Multistage vertical pumps. Pumping of clean non-loaded fluids in the domestic, agricultural and industrial sectors; pressurizing systems; irrigation; drinking and glycol water; water treatment; food industry; heating and air conditioning; washing system.

ADVANTAGES - Closed coupled and compact; silent; excellent efficiency that allows a reduction of running cost and power consumption; economical; over-dimensioned bearing for longer life of the machines: intermediate shaft guiding stage for concentricity of rotation

CONSTRUCTION FEATURES - Capacity: up to 26 m³/h; total Head: up to 125 m.; maximum working pressure: 8 bar 6 impellers. 14 bar > 6 impellers; maximum liquid temperature: from -15 to + 90°C (SV); from - 15 to 110°C (SL, SLX) ambient temperature: max 40°C.

MOTOR - 2 pole induction Motor; single phase 230V - 50Hz with thermal protector up to P2= 1,85 kW; three phase 230-400V - 50 Hz; insulation class F; protection degree IP 44.

MATERIALS - Flanged suction and delivery pump body: grey cast iron (SV,SL) AISI 304 chromo-nickel steel (SLX); flanged delivery pump body: cast iron; shell, impellers, diffusers: AISI 304 chromo-nickel steel; pump shaft: AISI 304 chromo-nickel steel; motor bracket: cast iron; mechanical seal: ceramic-graphite up to 6 stages - graphite-silicon carbide from 7 stages; intermediate shaft guiding stage bush: ceramic-tungsten carbide; pump body gasket: EPDM.



SL



18SL...10/11

U18S V/X - 500 / 6 T

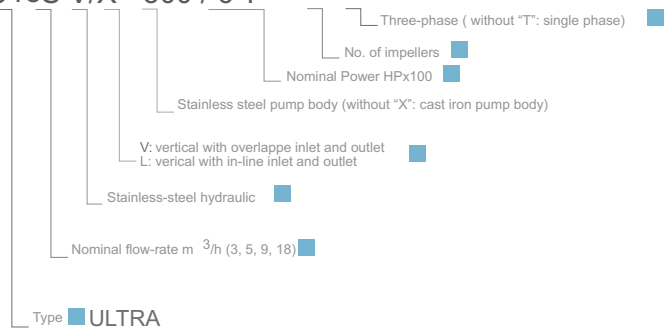

ULTRA SV /SL /SLX	
Construction features	
Flanged suction / delivery pump body	grey cast iron (SV/ SL); AISI 304 chromo-nickel steel (SLX)
Shell, impellers, diffusers, pump shaft:	AISI 304 chromo-nickel steel
Motor bracket	grey cast iron
Mechanical seal:	ceramic-graphite up to 6 stage graphite-silicon carbide from 7 stages
Intermediate shaft guiding stage bush	ceramic-tungsten carbide
Pump body gasket:	EPDM
Motor	
2 pole induction motor	1~ 230V-50Hz with thermal protector up to P2=1.85kW 3~ 230/400V-50Hz
Insulation class	F
Protection degree	IP 44
Limit of use	
Maximum working pressure	8 bar 6 impellers 14 bar > 6 impellers
Maximum liquid temperature	-15 + 90°C (SV); -15 + 110°C (SL/ SLX)
Ambient temperature	max 40°C

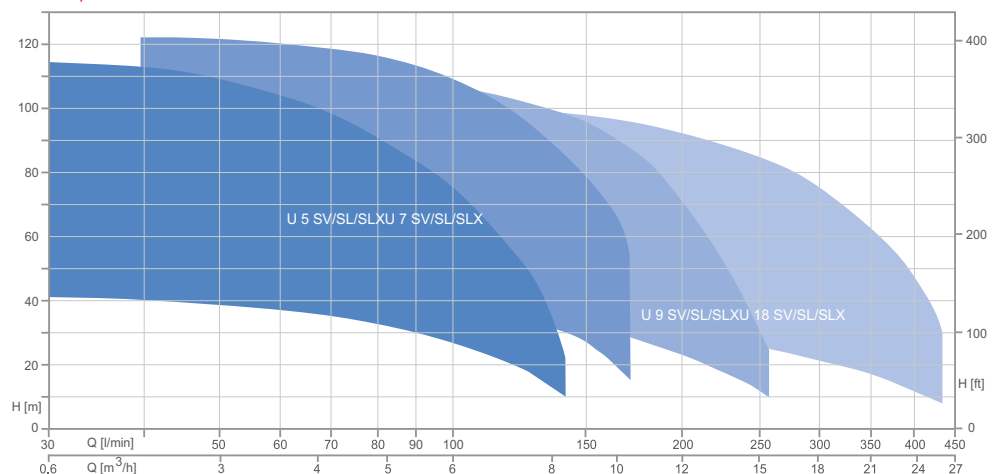

ULTRA 5 SL

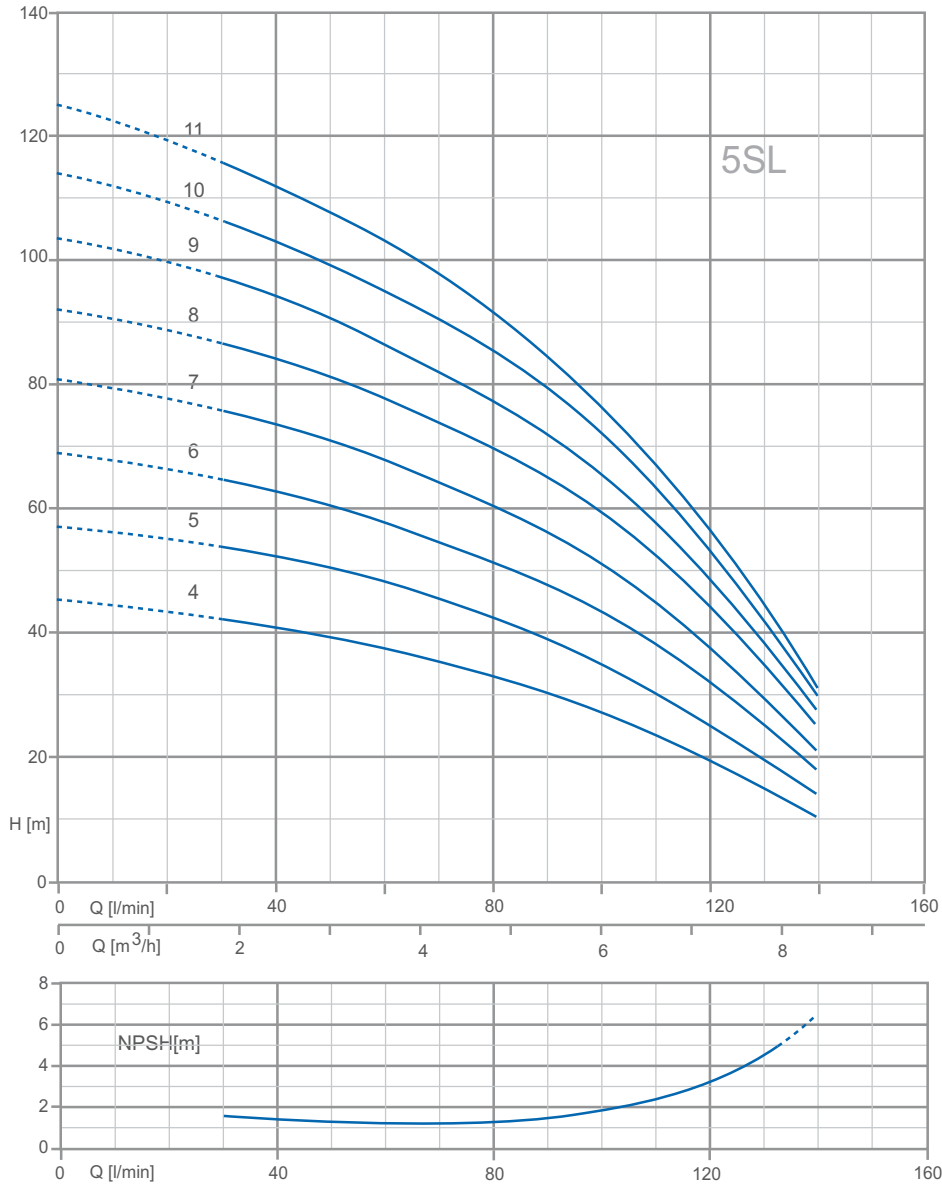

Technical data

ULTRA 5... SV / SL / SLX		P2P1		(kW)		AMPERE		Q (m³/h - l/min)							
1~	3~					1~3~		0	1.8	2.4	3.6	4.8	6	7.2	8.4
230 V - 50 Hz	230 / 400 V - 50 Hz	(HP)	(kW)	1~3~		1x230V 50Hz	3x400V 50Hz	0	30	40	60	80	100	120	140
U 5SV -120/4*	U 5SV-120/4 T*	1.2	0.9	1.09	1.08	4.9	2.4	45.5	42.2	40.1	37.2	32.9	27.4	19.8	10.4
U 5...-150/5	U 5...-150/5 T	1.5	1.1	1.39	1.31	6.5	2.7	57.2	53.4	51.7	47.6	42.3	35.2	25.7	14
U 5...-180/6	U 5...-180/6 T	1.8	1.3	1.63	1.55	7.3	3	68.9	64.4	62.3	57.5	51.5	43.5	32.6	18.1
U 5...-200/7	U 5...-200/7 T	2	1.5	1.94	1.77	8.7	3.3	81	75.5	73	67.4	60.3	51	38.6	21
U 5...-250/8	U 5...-250/8 T	2.5	1.85	2.2	2.07	10.1	4	92.1	86.5	84	77.8	70.1	60	45.5	26
U 5...-280/9	U 5...-280/9 T	2.8	2.1	2.45	2.27	11	4.2	103.4	96.7	93.5	86	77.1	65.6	48.7	27.6
U 5...-300/10	U 5...-300/10 T	3	2.2	2.67	2.57	11.9	4.7	114.2	106.4	102.9	95.2	85.2	72	53.3	30
U 5...-350/11	U 5...-350/11 T	3.5	2.57	2.85	2.76	12.9	4.9	125.1	115.7	111.8	102.6	91.6	77.1	57.1	30.7

* 120/4 : only SV type; solamente para el modelo SV; seulement pour le modèle SV; Только для модели SV;

ULTRA 7 SL

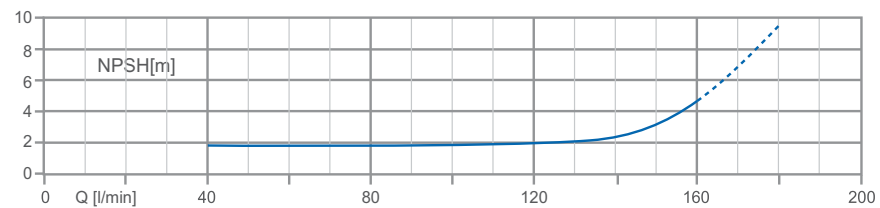
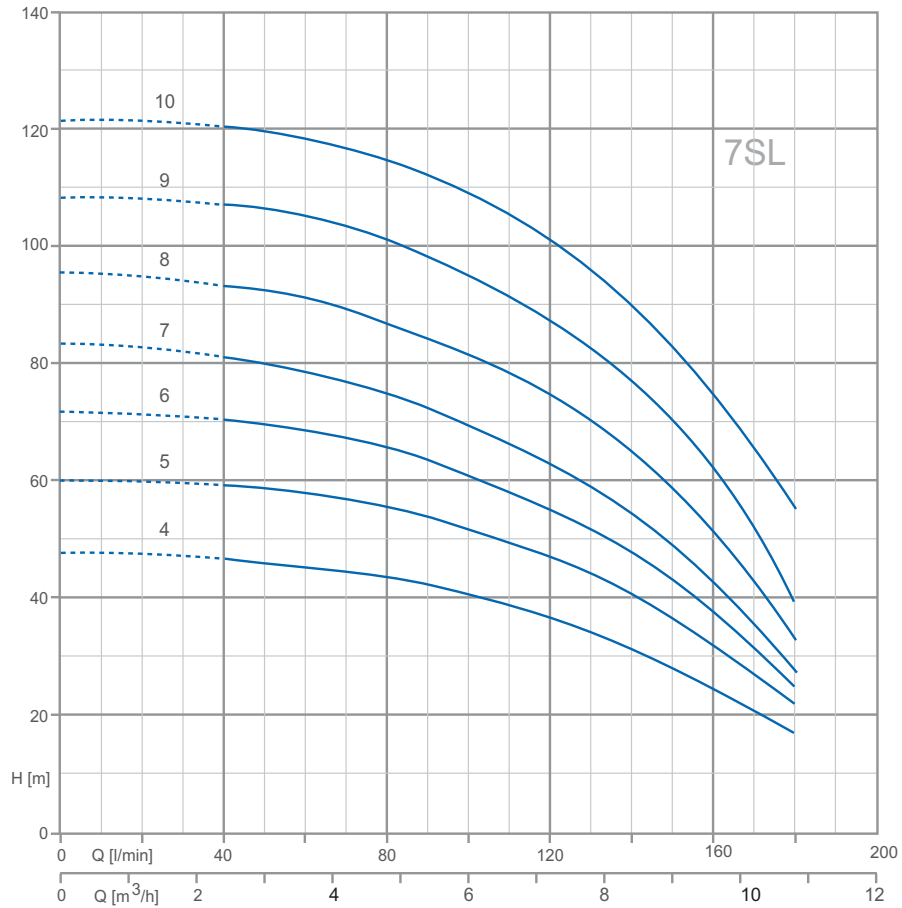

Technical data

ULTRA 7...SV / SL / SLX		P2		P1 (kW)		AMPERE		Q (m³/h - l/min)									
1~	3~					1~3~		0	2.4	3.6	4.8	6	7.2	8.4	9.6	10.8	
230 V - 50 Hz		230 / 400 V - 50 Hz		(HP)	(kW)	1~3~		0	40	60	80	100	120	140	160	180	
								H (m)									
U 7...-180/4	U 7...-180/4 T	1.8	1.3	1.69	1.62	7.7	3.1	48.0	46.3	45.7	43.6	40.4	36.4	31.4	25.0	17.2	
U 7...-250/5	U 7...-250/5 T	2.5	1.85	2.19	2.05	10.2	4.1	60.3	59.0	58.2	55.7	52.2	47.4	41.3	33.5	22	
U 7...-300/6	U 7...-300/6 T	3	2.2	2.53	2.44	11.4	4.8	72.5	70.5	69.2	66	61.5	55.7	47.8	37.8	24.7	
-	U 7...-350/7 T	3.5	2.57	-	2.84	-	5.1	83.5	80.7	78.8	74.7	69.4	62.6	53.9	42.7	27.5	
-	U 7...-400/8 T	4	3	-	3.3	-	6	95.6	93.3	91.4	87.2	81.6	74.2	64.8	51.9	33.0	
-	U 7...-450/9 T	4.5	3.31	-	3.81	-	6.5	108.5	106.6	105.1	101.0	95.0	87.2	76.6	62.6	39.5	
-	U 7...-550/10 T	5.5	4	-	4.32	-	7.9	121.5	120.1	119.3	115.3	109.2	100.8	89.8	75.0	55.4	

ULTRA 9 SL

ELECTRIC PUMPS
MULTISTAGE

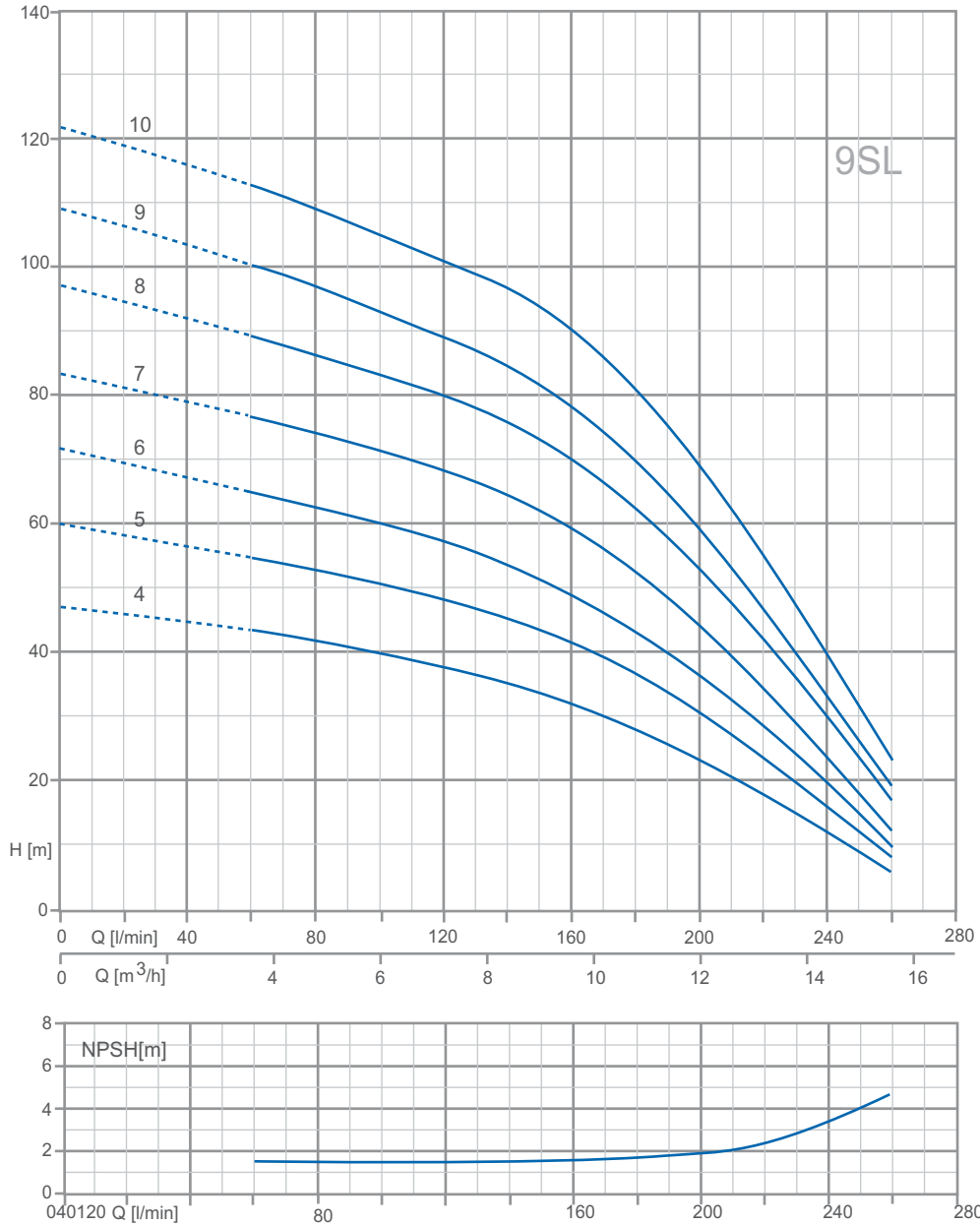

Technical data

ULTRA 9...SV / SL / SLX		P2P1		(kW)		AMPERE		Q (m³/h - l/min)											
1~	3~					1~3~		0	3.6	4.8	6	7.2	8.4	9.6	10.8	12	13.2	14.4	15.6
230 V - 50 Hz	230 / 400 V - 50 Hz	(HP)	(kW)	1~3~		1x230V 50Hz	3x400V 50Hz	H (m)											
U 9...-200/4	U 9...-200/4 T	2	1.5	1.88	1.77	8.4	3.3	47.6	43.5	42.1	40.1	38.1	35.7	32.7	28.9	24.2	19	13.1	7.1
U 9...-250/5	U 9...-250/5 T	2.5	1.85	2.36	2.23	10.8	4.3	60	54.8	53	51	48.2	45.4	42	37.3	31.6	25	18	10.6
U 9...-300/6	U 9...-300/6 T	3	2.2	2.78	2.58	12.5	4.9	71.8	64.9	63	59.9	57	53.7	49.7	44.3	37	29.5	20.8	11.1
-	U 9...-400/7 T	4	3	-	3.13	-	5.8	83.3	76.7	74.9	71.8	68.3	64.6	59.9	53.5	44.8	35.9	25.7	14.3
-	U 9...-450/8 T	4.5	3.31	-	3.72	-	6.4	97.3	89.5	87.3	84	80.5	76.5	71.6	64.8	54.9	44	32.4	19.7
-	U 9...-500/9 T	5	3.7	-	4.11	-	7	109	100	97.6	93.6	89.5	85	79.4	71.6	60.1	48	34.9	21.9
-	U 9...-550/10 T	5.5	4	-	4.58	-	8.3	122	112.8	110.5	106.5	102.2	97.3	91.6	82.8	70.7	57.1	42.3	26.5

ULTRA 18 SL

ELECTRIC PUMPS
MULTISTAGE

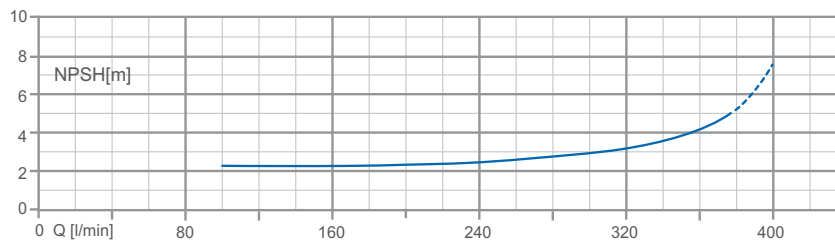
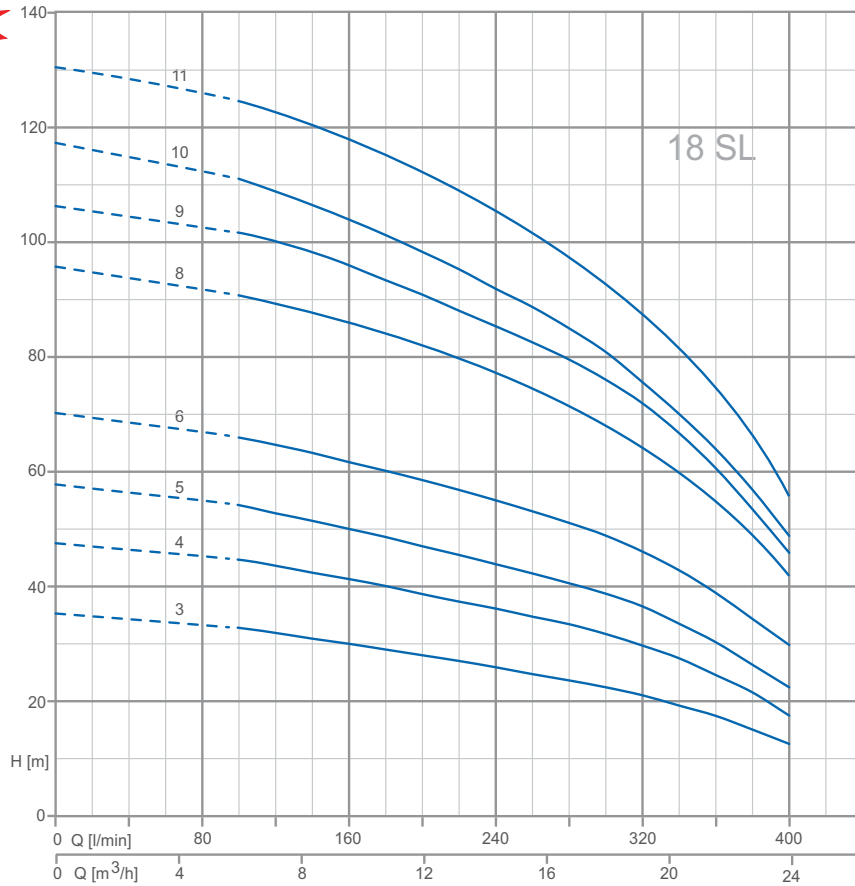

Technical data

ULTRA 18...SV / SL / SLX	P ₂		P ₁	Q (m ³ /h - l/min)																	
				AMPERE																	
				3~	0	6	7.2	8.4	9.6	10.8	12	13.2	14.4	15.6	16.8	18	19.2	20.4	21.6	22.8	24
3~	(HP)	(kW)	3~	3x400V 50Hz	H (m)																
U 18...-250/3 T	2.5	1.85	2.29	4.4	35.7	33.1	32.3	31.3	30.4	29.4	28.4	27.4	26.3	25.1	24	22.8	21.4	19.6	17.8	15.4	12.9
U 18...-400/4 T	4	3	3.11	5.7	47.9	45	44	42.8	41.7	40.5	39.1	37.8	36.6	35.2	33.9	32.2	30.2	28	25.1	22.1	18.1
U 18...-450/5 T	4.5	3.31	3.79	6.7	58.1	54.3	53.1	51.8	50.4	49	47.4	45.9	44.3	42.7	41	39.2	37	34	30.8	26.9	23
U 18...-550/6 T	5.5	4	4.63	8.7	70.5	66.4	65	63.6	62	60.5	58.9	57.2	55.4	53.5	51.5	49.3	46.3	43.3	39.4	34.9	30.4
U 18...-750/8 T	7.5	5.5	6.15	10.9	95.9	90.9	89.58	88	86.1	83.9	81.6	79.5	76.8	74.37	71.8	68.6	65	60.4	55.2	49	42.2
U 18...-900/9 T	9	6.6	7	12.7	106.4	101.8	100.4	98.6	96.1	93.5	91	88.2	85.5	82.7	79.7	76.2	72.1	66.9	60.8	53.67	46.1
U 18 SL/ SLX-850/10 T*	8.5	6.3	7.4	12.6	117.4	111.3	109.2	106.7	104	101.3	98.4	95.4	92	88.8	85.1	81	75.7	70.2	64.1	57	49
U 18 SL/ SLX-1000/11 T*	10	7.5	8.4	14.6	130.5	125	122.8	120.2	117.3	114.4	111.5	108.4	105.4	101.9	98	93.8	88.6	81.7	74.3	65.5	56.8

* - 850/10 T, - 1000/11 T: only SL / SLX type; seulement pour le modèle SL / SLX; solamente para el modelo SL / SLX;

ULTRA 5-7 SL

Dimensions

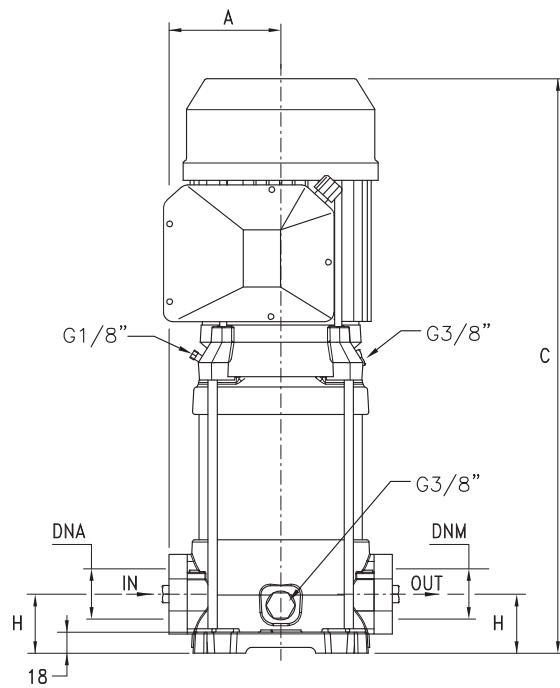
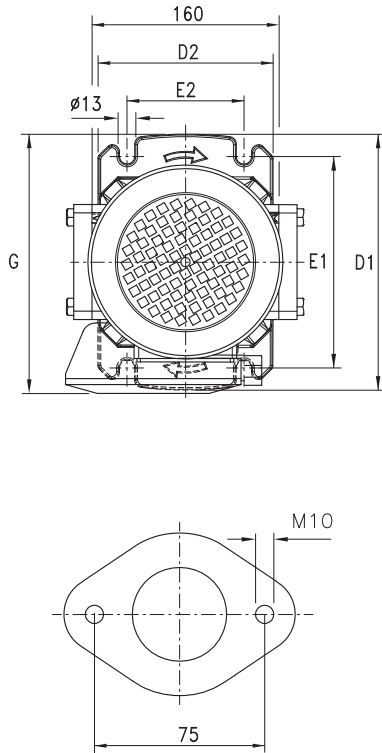

Technical data

ULTRA SL / L / SLX	DIMENSIONS (mm)								Kg			DNA	DNM
	A	C	D1	D2	E1	E2	G	H					
U 5...-150/5	98	459	220	150	180	100	228	50	23.7	22.4	22.2	1"1/4	1"1/4
U 5...-180/6	98	483	220	150	180	100	228	50	24.9	23.3	23.4		
U 5...-200/7	98	507	220	150	180	100	228	50	27.0	25.1	25.5		
U 5...-250/8	98	531	220	150	180	100	228	50	28.0	25.7	26.4		
U 5...-280/9	98	M 600	220	150	180	100	M 236 T 228	50	30.8	28.2	29.2		
		T 555											
U 5...-300/10	98	M 624	220	150	180	100	M 236 T 228	50	31.4	28.6	29.9		
		T 579											
U 5...-350/11	98	648	220	150	180	100	236	50	34.7	31.6	33.2		
U 7...-180/4	98	435	220	150	180	100	228	50	23.8	22.7	22.3		
U 7...-250/5	98	459	220	150	180	100	228	50	26.1	24.7	24.6		
U 7...-300/6	98	M 528	220	150	180	100	M 236 T 228	50	29.0	27.3	27.5		
		T 483											
U 7...-350/7	98	552	220	150	180	100	236	50	29.8	27.7	28.3		
U 7...-400/8	98	576	220	150	180	100	236	50	33.3	30.6	31.5		
U 7...-450/9	98	633	220	150	180	100	251	50	37.7	34.9	36.1		
U 7...-550/10	98	657	220	150	180	100	251	50	41.0	38.0	39.5		

ULTRA 9-18 SL

Dimensions

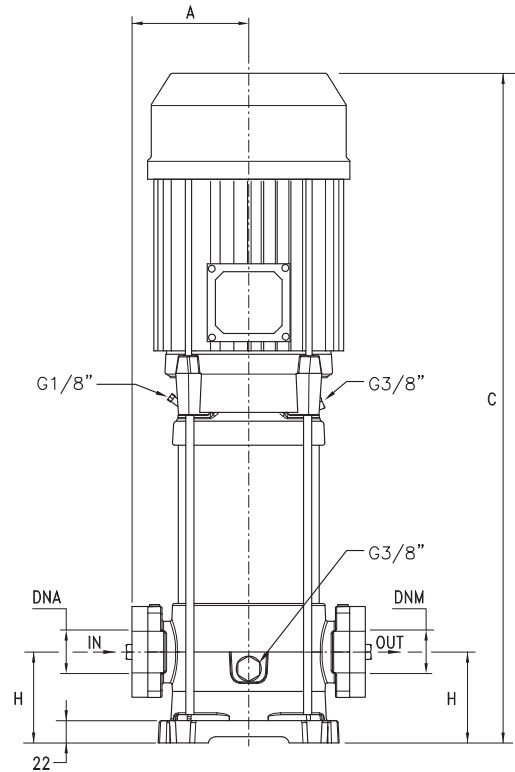
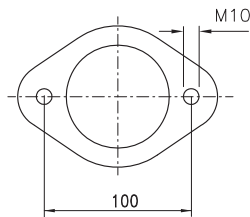
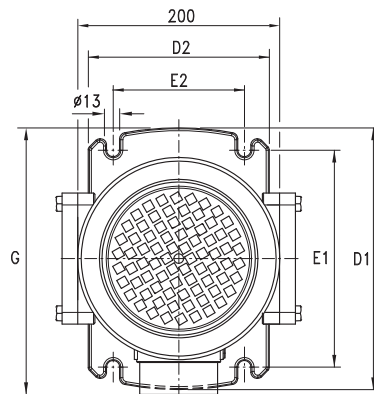

Technical data

ULTRA SL / L / SLX	DIMENSIONS (mm)								Kg			DNA	DNM
	A	C	D1	D2	E1	E2	G	H					
U 9...-200/4	118	490	260	180	215	130	248	80	29.9	28.6	28.1	1"1/2	1"1/2
U 9...-250/5	118	520	260	180	215	130	248	80	30.8	29.2	29.0		
U 9...-300/6	118	M 595 T 550	260	180	215		M 256 T 248	80	33.8	31.8	32.0		
U 9...-400/7	118	625	260	180	215	130	256	80	37.6	35.0	35.5		
U 9...-450/8	118	688	260	180	215	130	271	80	41.3	38.6	39.5		
U 9...-500/9	118	718	260	180	215	130	271	80	42.1	39.1	40.3		
U 9...-550/10	118	748	260	180	215	130	271	80	45.5	42.1	43.7	2"2"	
U 18...-250/3	118	492	260	180	215	130	248	90	33.5	32.1	31.6		
U 18...-400/4	118	575	260	180	215	130	256	90	36.1	34.2	34.2		
U 18...-450/5	118	646	260	180	215	130	271	90	40.4	38.1	38.5		
U 18...-550/6	118	683	260	180	215	130	271	90	44.4	41.5	42.5		
U 18...-750/8	118	804	260	180	215	130	280	90	54.3	50.4	52.4		
U 18...-900/9	118	842	260	180	215	130	280	90	54.6	50.3	52.7		
U 18...-850/10	118	1020	260	180	215	130	307	90	68.6	63.8	66.7		
U 18...-1000/11	118	1057	260	180	215	130	307	90	75.6	70.3	73.7		

CHARACTERISTICS

USES - Drainage pump with set-back Vortex type impeller for pumping charged waters and liquids with suspended solids; ideal for civil and household applications.

CONSTRUCTION FEATURES - Steel case and stainless steel suction grid; pump casing in stainless steel with openings measuring 1"1/2 and 2"; stainless steel set-back Vortex type impeller; double seal with oil barrier; silicon carbide on pump side, sealing ring on motor side; motor shaft in AISI 416 steel; world leading brand ball bearings; liquid temperature range 0 - 40 °C; supplied with 10 meters of H07 RNF cable. Available with or without float.

MOTOR - 2 pole electric induction motor in oil bath suitable for continuous operations; stator made with low-loss laminated electric sheet steel; insulation Class F; IP 68 protection; condenser inside. Thermal protection for single-phase models; the user is responsible for supplying protection for the three-phase models.

ON REQUEST - Other operating voltages and frequencies; special liquids.

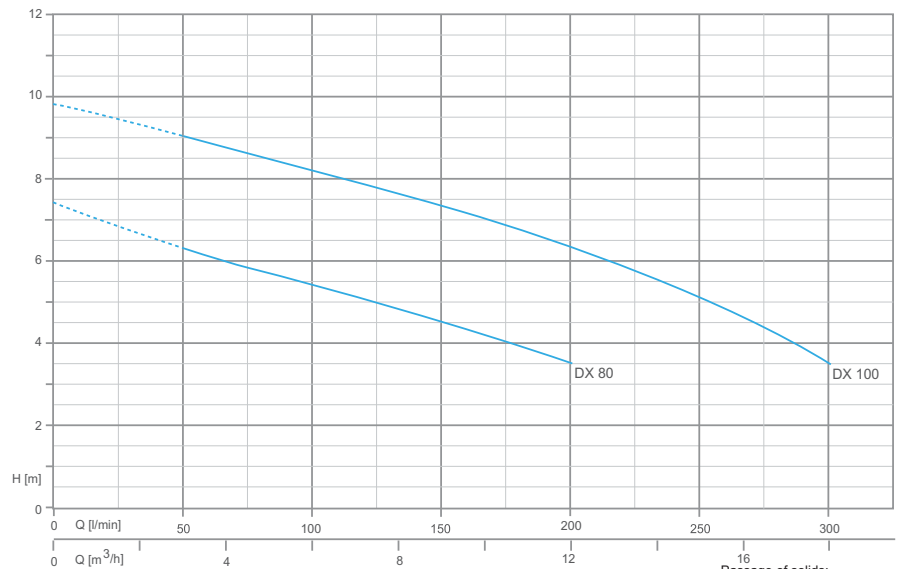

Dimensions

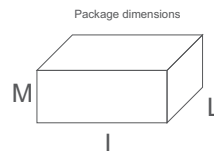
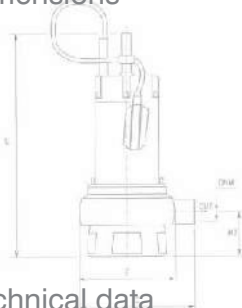

16
Passage of solids:
max.
Ø 28 mm

Depth of immersion:
max. 5m

Technical data

TYPE		P1	AMPERE		Q (m³/h - l/min)						
1~	3~		1~3~		0	3	6	9	12	15	18
					(W)	1x230V 50Hz	3x400V 50Hz	0	50	100	150
230 V - 50 Hz	230 / 400 V - 50 Hz	(W)	1x230V 50Hz	3x400V 50Hz	H (m)						
DX 80 G	-	1050	4.7	-	7.4	6.3	5.4	4.5	3.5	-	-
DX 80	DXT 80	1050	4.7	2.2	7.4	6.3	5.4	4.5	3.5	-	-
DX 100 G	-	1350	6.2	-	9.8	9	8.3	7.3	6.3	5.1	3.5
DX 100	DXT 100	1350	6.2	2.8	9.8	9	8.3	7.3	6.3	5.1	3.5

TYPE	DIMENSIONS (mm)								
	C	D	E	H2	DNM	I	L	M	
DX 80 G	395	183	160	100	1" 1/2	170	235	450	10
DX 100 G	395	183	160	100	1" 1/2	170	235	450	11.5

CHARACTERISTICS

USES - Drainage pump with set-back Vortex type impeller for pumping charged waters and liquids with suspended solid parts; ideal for civil and domestic use.

CONSTRUCTION FEATURES -Steel case and stainless steel suction grid; cast iron pump casing with openings measuring 1"1/2 and 2"; stainless steel set-back Vortex type impeller; double seal with oil barrier; silicon carbide on pump side, sealing ring on motor side; motor shaft in AISI 416 steel ; world leading brand ball bearings; liquid temperature range 0 - 40 °C; supplied with 10 meters of H07 RNF cable. Available with or without float.

MOTOR - 2 pole electric induction motor in oil bath suitable for continuous operations; stator made with low-loss laminated electric sheet steel; insulation Class F; IP 68 protection; condenser inside. Thermal protection for single-phase models; the user is responsible for supplying protection for the three-phase models.

ON REQUEST - Other operating voltages and frequencies. Special liquids.

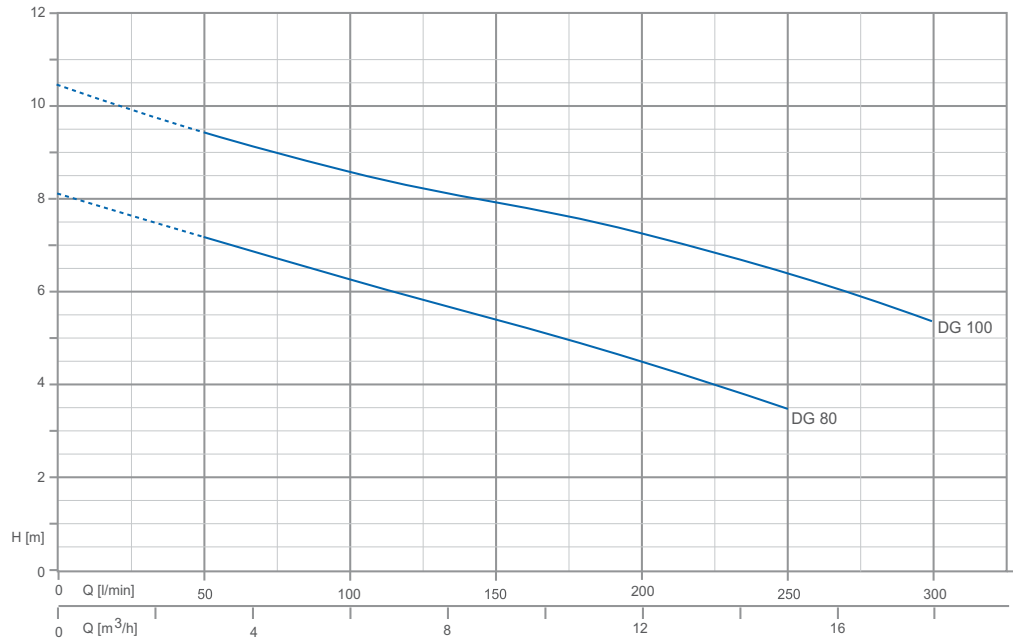

Dimensions

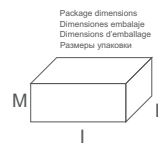
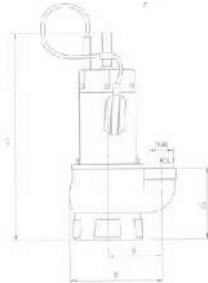

Passage of solids:
max.
Ø 35 mm

Depth of immersion:
max. 5m

Technical data

TYPE		P1 (W)	AMPERE		Q (m³/h - l/min)						
1~	3~		1~3~		0	3	6	9	12	15	18
					0	50	100	150	200	250	300
230 V - 50 Hz	230 / 400 V - 50 Hz		1x230V 50Hz	3x400V 50Hz	H (m)						
DG 80 G	-	1050	4.7	-	8.3	7.4	6.4	5.6	4.8	3.7	-
DG 80	DGT 80	1050	4.7	2.2	8.3	7.4	6.4	5.6	4.8	3.7	-
DG 100 G	-	1350	6.2	-	10.4	9.4	8.7	8.1	7.4	6.6	5.7
DG 100	DGT 100	1350	6.2	2.8	10.4	9.4	8.7	8.1	7.4	6.6	5.7

TYPE	DIMENSIONS (mm)								 Kg
	B	C	D	H2	DNM	I	L	M	
DG 80 G	110	410	230	160	1" 1/2	170	235	450	12
DG 100 G	110	410	230	160	1" 1/2	170	235	450	13.5

CHARACTERISTICS

USES - impeller rotor for pumping liquids with suspended solids. Characterised by head in ratio to the type and size of the machine.

CONSTRUCTION FEATURES - Steel case and stainless steel suction grid; pump casing in stainless steel with openings measuring 1"1/2 and 2"; brass impeller; double seal with oil barrier; silicon carbide on pump side, sealing ring on motor side; motor shaft in AISI 416 steel; world leading brand ball bearings; liquid temperature range 0 - 40°C; supplied with 10 meters of H07 RNF cable. Available with or without float.

MOTOR - 2 pole electric induction motor in oil bath suitable for continuous operations; stator made with low-loss laminated electric sheet steel; insulation Class F; IP 68 protection; condenser inside. Thermal protection for single-phase models; the user is responsible for supplying protection for the three-phase models.

ON REQUEST - Other operating voltages and frequencies; special liquids.

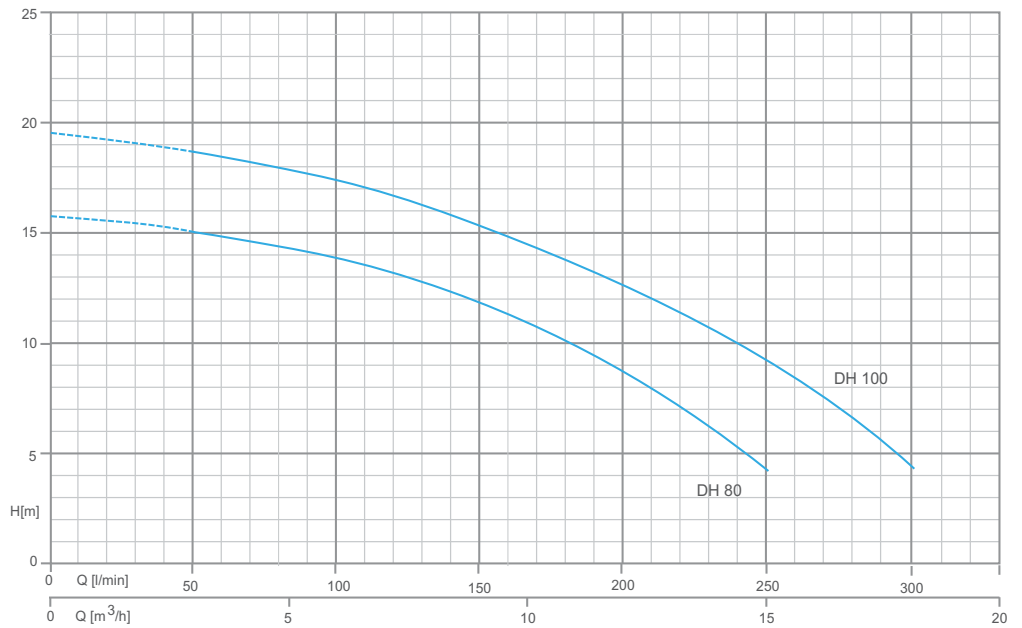

Dimensions

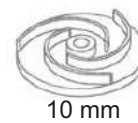
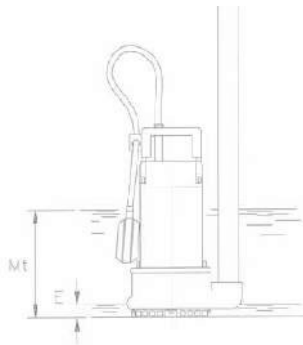
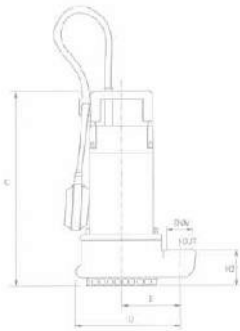

Package dimensions
Maximum emptying level:
15 mm (E min.)
Depth of immersion:
max. 5m

Technical data

TYPE		P1	AMPERE		Q (m³/h - l/min)							
1~	3~		1~3~		0	3	6	9	12	15	18	
230 V - 50 Hz	230 / 400 V - 50 Hz	W	1x230V 50Hz	3x400V 50Hz	H (m)							
DH 80 G	-	980	4.3	2.1	15.7	14.9	13.8	11.7	8.6	4.3	-	
DH 80	DH 80 T	980	4.3	2.1	15.7	14.9	13.8	11.7	8.6	4.3	-	
DH 100 G	-	1370	4.3	2.8	19.4	18.5	17.1	15.2	12.6	9.3	4.4	
DH 100	DH 100 T	1370	4.3	2.8	19.4	18.5	17.1	15.2	12.6	9.3	4.4	

TYPE	DIMENSIONS (mm)										
	B	C	D	H2	DNM	E min.	Mt	I	L	M	
DH 80 G	105	330	218.5	70	1" 1/4	15	170	180	255	380	12
DH 100 G	105	330	218.5	70	1" 1/4	15	170	180	255	380	14



CHARACTERISTICS

USES - Single-channel centrifugal drainage pump: besides the high capacity it guarantees excellent head; ideal for civil and industrial applications; specifically designed for very heavy use; available in the mobile or permanent versions with duck foot arrangement.

CONSTRUCTION FEATURES - Cast iron pump casing with flanged delivery opening; impeller in cast iron; double mechanical silicon carbide gasket with oil barrier on pump side, ceramic graphite on motor side; motor shaft in AISI 304 steel on the hydraulic side; liquid temperature range 0 - 40 °C; supplied with 10 meters of H07 RNF cable; for single-phase models a control board must be used complete with starter capacitor (35 F for the version 1,5 HP, 50F for the version 2 HP).

MOTOR - 4 pole electric induction motor in oil bath suitable for continuous operations; stator made with low-loss laminated electric sheet steel; insulation Class F; IP 68 protection; the user is responsible for motor protection.

ON REQUEST - Other operating voltages and frequencies; special liquids.



DV 150-1000

DV 150-1000/P

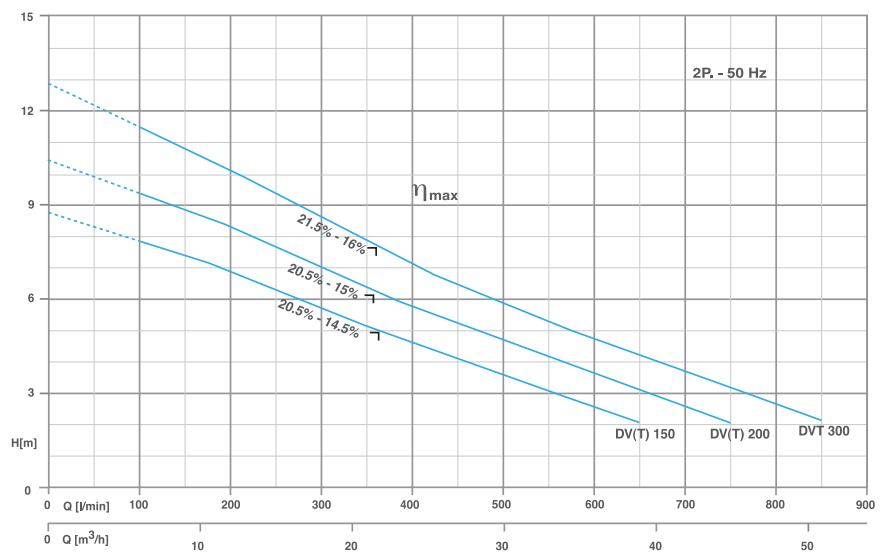

Technical data

TYPE		P2		P1 (kW)		Q (m³/h - l/min)									
1~	3~	(HP)	(kW)	1~	3~	0	6	12	18	24	30	39	45	51	
						0	100	200	300	400	500	650	750	850	
						H (m)									
DV 150 *	DVT 150	1.5	1.1	2.65	2.35	8.7	7.8	6.8	5.6	4.6	3.6	2	-	-	
DV 200 *	DVT 200	2	1.5	3.4	3.1	10.4	9.4	8.3	7	5.7	4.6	3.1	2	-	
-	DVT 300	3	2.2	-	3.42	12.7	11.5	10	8.6	7	5.9	4.4	3.1	2	

(*) Starting capacitor for single phase pumps must be provided by user through an external control box (35kF for 1,5 HP pumps; 50kF for 2 HP pumps) monofase

COMPONENTS	MATERIALS
Motor housing, hydraulic part:	grey cast iron
Electric motor:	asynchronous type, oil immersed
Shaft (pump side):	stainless steel
Motor side mechanical seal:	carbon - ceramic
Pump side mechanical seal:	silicon carbide - silicon carbide
Bolts:	A2 stainless steel
Foot support:	galvanized iron
Gaskets (O-Rings):	NBR rubber

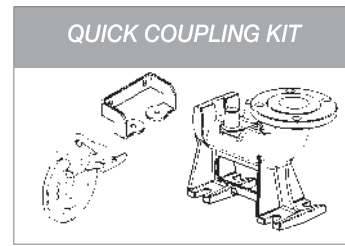

Counterflange

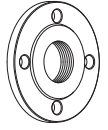

Dimensions

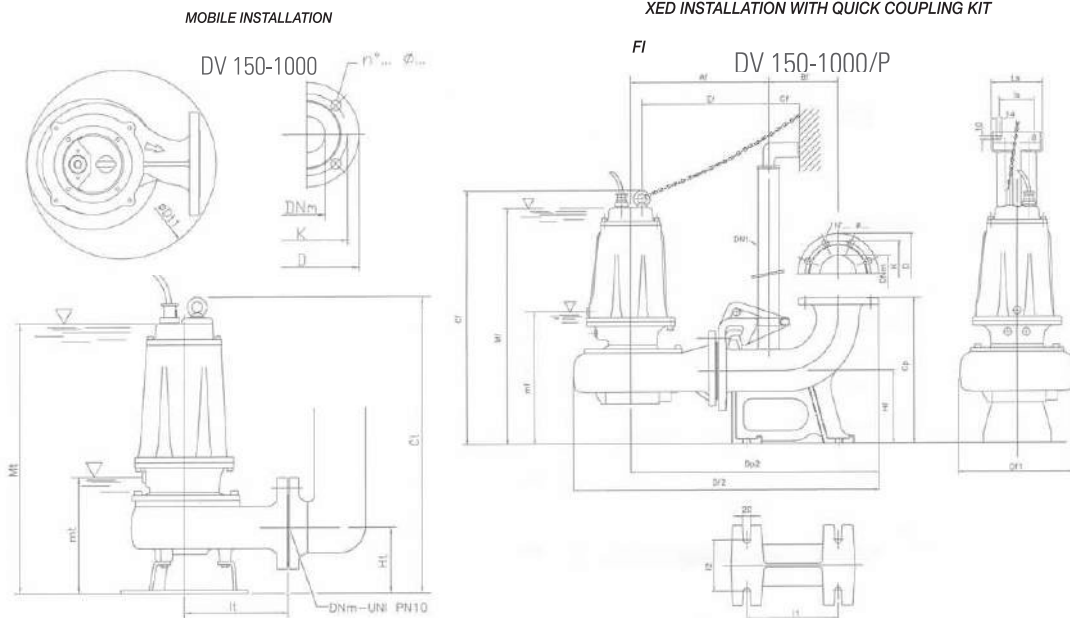

Technical data

mt/mf: lowest working level

Mt/Mf: lowest level for continuous duty

TYPE	DIMENSIONS (mm)					Flange UNI PN 10				Kg
	Ct	Ht	It	mt	Mt	DNm	K	D	n°...N...	
DVT 150	551	123	191	243	513	65	145	185	4...18...	39
DV 150-DVT 200	551	123	191	243	513	65	145	185	4...18...	40
DVT 200-DVT 300	551	123	191	243	513	65	145	185	4...18...	41

TYPE	DIMENSIONS (mm)																Flange UNI PN 10				
	Af	Bf	Cf	Cp	Df1	Df2	Dp2	DNt	Ef	Gf	Hf	I1	I2	Is	LS	mf	Mf	DNm	K	D	n°...N...
DVT 150/P	303	145	559	260	200	639	327.5	1" 1/4	280	55	130	200	100	95	140	251	521	65	145	185	4...18...
DV 150-DVT 200/P	303	145	559	260	200	639	327.5	1" 1/4	280	55	130	200	100	95	140	251	521	65	145	185	4...18...
DV 200-DVT 300/P	303	145	559	260	200	639	327.5	1"1/4	280	55	130	200	100	95	140	251	521	65	145	185	4 18

CHARACTERISTICS

USES - Single-channel centrifugal drainage pump: besides the high capacity it guarantees excellent head; ideal for civil and industrial applications; specifically designed for very heavy use; available in the mobile or permanent versions with duck foot arrangement.

CONSTRUCTION FEATURES - Cast iron pump casing with flanged delivery opening; impeller in cast iron; double mechanical silicon carbide gasket with oil barrier on pump side, ceramic graphite on motor side; motor shaft in AISI 304 steel on the hydraulic side; liquid temperature range 0 - 40 °C; supplied with 10 meters of H07 RNF cable; for single-phase models a control board must be used complete with starter capacitor (35F for the version 1,5 HP, 50F for the version 2 HP).

MOTOR - 4 pole electric induction motor in oil bath suitable for continuous operations; stator made with low-loss laminated electric sheet steel; insulation Class F; IP 68 protection; the user is responsible for motor protection.

ON REQUEST - Other operating voltages and frequencies; special liquids.



DM 160-1000

DMT 160-1000/P

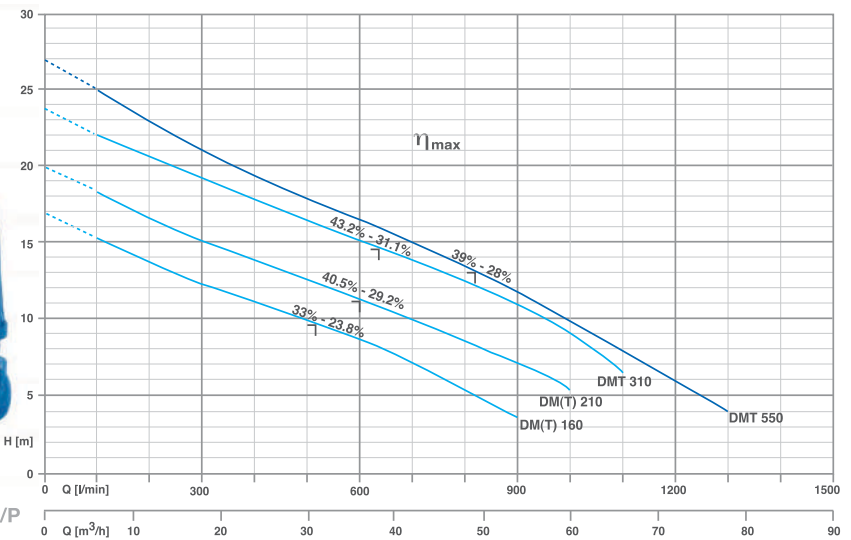

Technical data

TYPE		P2		P1 (kW)		Q (m³/h - l/min)												
1~	3~	(HP)	(kW)	1~	3~	0	6	12	18	24	30	36	42	48	54	60	66	78
						0	100	200	300	400	500	600	700	800	900	1000	1100	1300
						H (m)												
* DM 160	DMT 160	1.5	1.1	2.8	2.6	17.0	15.3	13.8	12.3	11.0	9.8	8.4	7.1	5.5	3.8	-	-	-
* DM 210	DMT 210	2	1.5	3.3	3.1	19.9	18.4	16.7	15.2	13.8	12.4	11.3	10.1	8.6	7.0	5.2	-	-

(*) Starting capacity for single phase units must be provided by user.

Free passage

50 mm (DM 160-210-310)
45 (DMT 550)

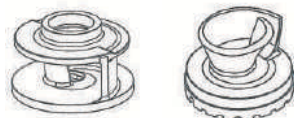

Depth of immersion:
max 20m

ACCESSORIES

COMPONENTS	MATERIALS
Motor housing, hydraulic part:	grey cast iron
Electric motor:	asynchronous type, oil immersed
Shaft (pump side):	stainless steel
Motor side mechanical seal:	carbon - ceramic
Pump side mechanical seal:	silicon carbide - silicon carbide
Bolts:	A2 stainless steel
Foot support:	galvanized iron
Gaskets (O-Rings):	NBR rubber

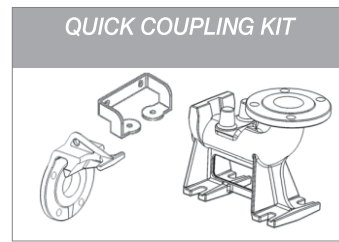

Counterflange

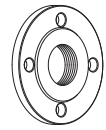

Dimensions

MOBILE INSTALLATION

DM 160-1000

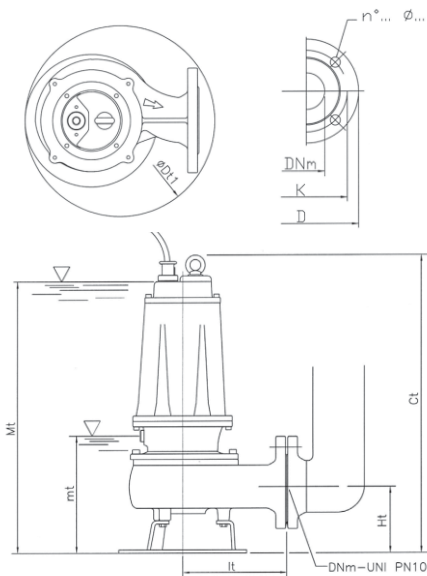

FIXED INSTALLATION WITH QUICK COUPLING KIT

DMT 160-1000/P

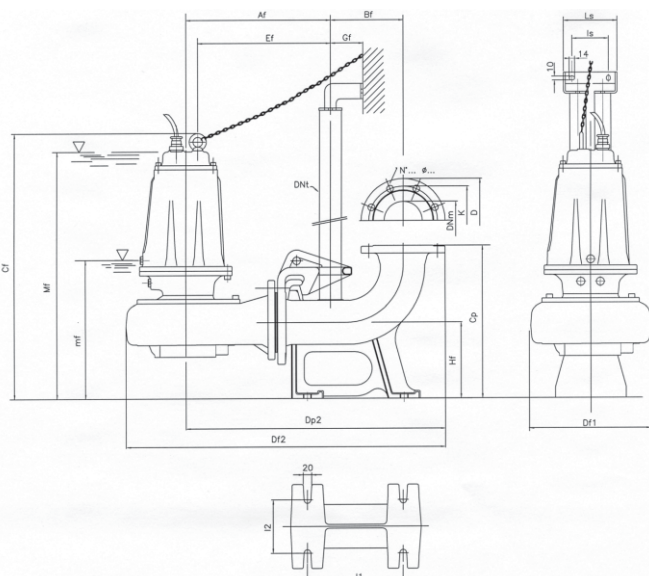

Technical data

Mt/Mf: lowest level for continuous duty
mt/mf: lowest working level

TYPE	DIMENSIONS (mm)						Flange UNI PN10				Kg
	Ct	øDt1	Ht	lt	mt	Mt	DNm	K	D	n°...ø...	
DMT 160	551	308	123	191	243	513	65	145	185	4...18...	39
DM 160-DMT 210	551	308	123	191	243	513	65	145	185	4...18...	40
DM 210-DMT 310	551	308	123	191	243	513	65	145	185	4...18...	41

TYPE	DIMENSIONS (mm)																Flange UNI PN10			
	Af	Bf	Cf	Cp	Df1	Df2	Dp2	DNt	Ef	Gf	Hf	I1	I2	Is	Ls	mf	Mf	DNm	K	D
DMT 160 / P	303	145	560	260	200	639	327.5	1" 1/4	280	55	130	200	100	95	140	251	521	65	145	185
DM 160-DMT 210 / P	303	145	560	260	200	639	327.5	1" 1/4	280	55	130	200	100	95	140	251	521	65	145	185
DM 210-DMT 310 / P	303	145	560	260	200	639	327.5	1" 1/4	280	55	130	200	100	95	140	251	521	65	145	185

CHARACTERISTICS

Automatic working pressure systems build-up with centrifugal or self-priming electropumps. Each set, ready for the installation, is made by an electropump, a pre-rated and adjustable pressure switch, pressure gauge, connector (and eventually a flexible hose with s.s sheath), membrane tank or protective starting device with built-in check valve and no-flow switch. The set specification and performances are related to the adapted electropump tank capacity and pressure switch rating.



CAM 100-24 I



PM 45-24 I



INOX 100-24 I

Technical data

TYPE		P2P1	(kW)		Pipe		24lt H	24lt V
1~	3~		1~3~		Aspirazione Suction (lG)	Mandata Delivery (lG)		
230 V - 50 Hz	230 / 400 V - 50 Hz	(HP/kW)						
PM 45	-	0.5/0.37	0.49	-	1	1	■	
PM 80	-	1/0.74	1.11	-	1	1		■
CAM 75	-	0.8/0.59	0.8	-	1	1		■
CAM 100	CAMT 100	1/0.74	1.02	-	1	1	■	■
INOX 80	-	0.8/0.59	0.79	-	1	1	■	■
INOX 100	-	1/0.74	0.98	-	1	1	■	■

TANKS



UTILIZATION - Interchangeable membrane expansion tanks; the pre-charge pressure in the tank guarantees a water reserve but also reduces the number of startups of the connected pump; the membranes are certified for use with foodstuffs; they may be in EPDM or butyl depending on the model.

CONSTRUCTION CHARACTERISTICS - Flanges in galvanised steel or AISI 304 stainless steel; tanks in carbon steel coated with powder paint or in AISI 304 stainless steel; pre-charge valve with protective cover.



TYPE	DESCRIPTION
AS 24	24 lt. Spherical tank
ACV 24	24 lt. Horizontal tank
ACZ 24	24 lt. Horizontal tank
AC 24 INOX	24 lt. Stainless steel tank
AC 50	50 lt. Horizontal tank
AC 100	100 lt. Horizontal tank
AC 200	200 lt. Horizontal tank
AV 50	50 lt. Vertical tank
AV 100	100 lt. Vertical tank
AV 200	200 lt. Vertical tank
AV 500	500 lt. Vertical tank

RUBBERS



TYPE	DESCRIPTION
MZ 24	EPDM rubber for ACZ 24 lt.
M 24	EPDM rubber for AS 24 - ACV 24
M 50	Butile rubber for AC 50 - AV 50
M 100	Butile rubber for AC 100 - AV 100
M 200	Butile rubber for AC 200 - AV 200
M 500	Butile rubber for AC 500 - AV 300

**KIT 24 SF**

AS 24 - 24 lt. Spherical tank + Italtecnica PM/5 + 0-6 bar pressure gauge rear connection
+ R5 5 way brass connector

KIT 24 CL

ACV 24 - 24 lt. Horizontal tank + Italtecnica PM/5 + 0-6 bar pressure gauge
rear connection +Flexible hose with bend 1"x 530 x1"+ R5 5 way brass connector

■ ■ ■ PRESSURE SWITCH



TYPE	DESCRIPTION	RANGE AT RISING PRESSURE (bar)
PM / 5	Italtecnica	1 - 5
PM/12	Italtecnica	3 - 12
PT/12	Italtecnica	3 - 12

■ ■ ■ PRESSURE GAUGES

TYPE	DESCRIPTION
PR 6	0-6 bar rear connection
PR 12	0-12 bar rear connection
PR 6R	0-6 bar bottom connection



FLEXIBLES

TYPE	DESCRIPTION
FL 600	Flexible hose with bend 1"x600x1"
FL 850	Flexible hose with bend 1"x850x1"
FL 900	Flexible hose with bend 1"x900x1"

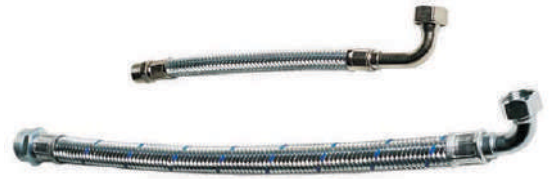

CONNECTORS

TYPE	DESCRIPTION
R3	3 way brass connector
R5	5 way brass connector



VALVES

TYPE	DESCRIPTION
VF 1"	foot valve 1"
VF 1" 1/4	foot valve 1" 1/4
VF 1" 1/2	foot valve 1" 1/2
VF "2	foot valve 1" 1/2
VR 1"	check valve 1"
VR 1" 1/4	check valve 1" 1/4
VR 1" 1/2	check valve 1" 1/2
VR 2"	check valve 1"



FLOAT SWITCHES WITH CONTERWEIGHT

TYPE	DESCRIPTION
GK 2	Key 2 mt. cable length
GK 3	Key 3 mt. cable length
GK 5	Key 5 mt. cable length
GK 10	Key 10 mt. cable length
GF 2	Fox 2 mt. cable length
GF 10	Fox 10 mt. cable length



GK

GF

GENERAL CONSTRUCTION CHARACTERISTICS



TYPE	P ²		Q	H	Tmax	P max
	HP	KW	(l/min)	(m)	water	(bar)
CAM 550	0.6	0.44	5-40	37-20	50	6
CAM 50	0.6	0.44	5-40	37-20	50	6
CAM 575	0.8	0.59	5-40	45-25	50	6
CAM 75	0.8	0.59	5-40	45-25	50	6
CAM 100	1	0.74	10-50	47-27	50	6
JMRC 80	0.8	0.59	5-35	35-11.5	50	6
INOXR 80	0.8	0.59	5-35	42-12	50	6
INOX 80	0.8	0.59	5-35	43-15	50	6
INOX 100	1	0.74	5-45	46-25	50	6
CAB 150	1.5	1.1	20-90	56.5-32	50	8
CAB 200	2.2	1.65	20-110	59.5-34	50	8
CAB 300	3	2.2	20-140	62-32	50	8
PM 45	0.5	0.37	5-35	35-9	90	6
PM 45 BR	0.5	0.37	5-35	35-9	90	6
PM 45 A	0.5	0.37	5-35	35-9	50	6
PM 80	1	0.74	10-50	56-18	90	8
CP 45	0.5	0.37	5-35	35-9	90	6
CP 75	1	0.74	10-50	56-18	90	8
MD 75	0.8	0.59	10-45	41-6	90	8
MD 100	1	0.74	10-45	48-9	90	8
CM 50	0.5	0.37	20-90	20.5-12	50	6
CM 75	0.8	0.59	20-105	26-14	50	6
CM 100	1	0.74	20-105	32.5-21	50	6
CM 160-164	1.5	1.1	20-110	39.3-29.5	90/50	8
CM 210-214	2.2	1.65	20-120	44.1-33.5	90/50	8
CMT 210-214	2.2	1.65	20-120	48.7-39.4	90/50	8
CM 310-314	3	2.2	20-130	54.5-41.9	90/50	8
CM 400	4	3	50-300	46.7-33.5	90	8
CMT 550	5.5	4	50-350	56.5-42.5	90	8
CH 150	1.5	1.1	100-500	24.2-4	90	6
CH 200	2	1.5	100-500	28-8	90	6
CH 300	3	2.2	100-500	32-13.5	90	6
CH 350	3	2.2	100-650	26-7	90	6
CH 400	4	3	100-700	31.8-12.3	90	6
CHT 550	5.5	4	100-700	37-19	90	6
CR 75-76	0.8	0.59	50-250	14-6.5	50	6
CR 100-102	1	0.74	50-280	19.5-10.5	50	6
CM 32-160 C	2	1.5	75-350	24.4-14.1	90	10
CM 32-160 B	3	2.2	100-400	28.5-14.8	90	10
CM 32-160 A	4	3	100-450	36.4-22.3	90	10
CM 32-200 C	5.5	4	100-450	40-27	90	10
CM 32-200 B1	7.5	5.5	100-600	47.5-24.5	90	10
CM 32-200 B	7.5	5.5	100-600	52-28.6	90	10
CM 32-200 A1	10	7.5	100-600	56.0 - 33.0	90	10
CM 32-200 A	10	7.5	100-600	60.5-38.5	90	10
CM 32-250 C	12.5	9.2	125-500	68.5-50.5	90	10
CM 32-250 B	15	11	125-500	81-66.5	90	10
CM 32-250 A1	20	15	125-500	90.0-75.5	90	10
CM 32-250 A	20	15	125-500	92-80	90	10
CM 40-125 C	2	1.5	125-500	17.6-13.3	90	10
CM 40-125 B	3	2.2	125-550	21.3-17	90	10
CM 40-125 A	4	3	150-600	25.8-21.1	90	10

GENERAL CONSTRUCTION CHARACTERISTICS



TYPE	P ₂		Q	H	Tmax	P max
	HP	KW	(l/min)	(m)	water	(bar)
CM 40-160 B	4	3	150-600	30.1-21	90	10
CM 40-160 A	5.5	4	150-650	35.6-25.4	90	10
CM 40-200 B	7.5	5.5	150-650	47-33.4	90	10
CM 40-200 A	10	7.5	150-700	57.8-43.9	90	10
CM 40-250 C	12.5	9.2	150-700	64.3-45.5	90	10
CM 40-250 B	15	11	150-700	74.6-56	90	10
CM 40-250 A1	20	15	150-700	84.0-65.8	90	10
CM 40-250 A	20	15	150-700	90.4-76	90	10
CM 50-125 B	4	3	200-1200	20-11.2	90	10
CM 50-125 A	5.5	4	250-1200	25-16.5	90	10
CM 50-160 B1	7.5	5.5	350-1300	28.3-13.2	90	10
CM 50-160 B	7.5	5.5	350-1300	30.5-16.8	90	10
CM 50-160 A1	10	7.5	350-1300	34.8-20.2	90	10
CM 50-160 A	10	7.5	350-1300	37-24.5	90	10
CM 50-200 C	12.5	9.2	400-1200	45.7-24.5	90	10
CM 50-200 B	15	11	400-1200	51-32	90	10
CM 50-200 A1	20	15	400-1200	57.3-40.0	90	10
CM 50-200 A	20	15	400-1200	58.3-38.8	90	10
CM 50-250 C	20	15	450-1300	70.8-50.5	90	10
CM 50-250 B	25	18.5	450-1300	78-58.3	90	10
CM 50-250 A	30	22	450-1300	89.5-71.7	90	10
CM 65-125 B1	7.5	5.5	500-2000	19.1-10.9	90	10
CM 65-125 B	7.5	5.5	500-2000	21-12.3	90	10
CM 65-125 A1	10	7.5	500-2200	23.1-13.0	90	10
CM 65-125 A	10	7.5	500-2200	24.8-15	90	10
CM 65-160 C	12.5	9.2	700-2400	31.2-16	90	10
CM 65-160 B	15	11	700-2400	34.6-21.1	90	10
CM 65-160 A1	20	15	700-2400	38.5-25.7	90	10
CM 65-160 A	20	15	700-2400	40.6-29.8	90	10
CM 65-200 C1	20	15	900-2200	41.5-27.8	90	10
CM 65-200 C	20	15	900-2200	44.8-32	90	10
CM 65-200 B	25	18.5	900-2200	49.5-38	90	10
CM 65-200 A	30	22	900-2400	56.7-44	90	10
CM 65-250 B	40	30	900-2400	79.5-48.5	90	10
CM 65-250 A	50	37	900-2600	89.5-54	90	10
CM 80-160 E	12.5	9.2	1100-3000	22.4-11.2	90	10
CM 80 -160 D	15	11	1100-3000	26.4-15.1	90	10
CM 80 -160 C1	20	15	1100-3250	29.5-15.2	90	10
CM 80-160 C	20	15	1100-3250	30.7-17.2	90	10
CM 80-160 B	25	18.5	1100-3500	35.0-21.0	90	10
CM 80-160 A	30	22	1100-3750	39.8-23.5	90	10
CM 80-200 B	40	30	1400-3750	50.8-38.6	90	10
CM 80-200 A	50	37	1600-4000	59.6-46.1	90	10
U 5SV-102/4	1.2	0.9	30-140	42.8-10.4	90	8
U 5SV // SL-SLX-150/5	1.5	1.1	30-140	53.4-14	90 // 110	8
U 5 SV // SL-SLX-180/6	1.8	1.3	30-140	64.4-18.1	90 // 110	8
U 5 SV // SL-SLX-200/7	2	1.5	30-140	75.5-21	90 // 110	14
U 5 SV // SL-SLX-250/8	2.5	1.85	30-140	86.5-26	90 // 110	14
U 5 SV // SL-SLX-280/9	2.8	2.1	30-140	96.7-27.6	90 // 110	14
U 5 SV // SL-SLX-300/10	3	2.2	30-140	106.4-30	90 // 110	14
U 5 SV // SL-SLX-350/11	3.5	2.57	30-140	115.7-30.7	90 // 110	14
U 7 SV // SL-SLX-180/4	1.8	1.3	40-180	46.3-17.2	90 // 110	8
U 7 SV // SL-SLX-250/5	2.5	1.85	40-180	59-22	90 // 110	8
U 7 SV // SL-SLX-300/6	3	2.2	40-180	70.5-24.7	90 // 110	8
U 7 SV // SL-SLX-350/7 T	3.5	2.57	40-180	80.7-27.5	90 // 110	14
U 7 SV // SL-SLX-400/8 T	4	3	40-180	93.3-33	90 // 110	14
U 7 SV // SL-SLX-450/9 T	4.5	3.31	40-180	106.6-39.5	90 // 110	14
U 7 SV // SL-SLX-550/10 T	5.5	4	40-180	120.1-55.4	90 // 110	14
U 9 SV // SL-SLX-200/4	2	1.5	60-260	43.5-7.1	90 // 110	14
U 9 SV // SL-SLX-250/5	2.5	1.85	60-260	54.8-10.6	90 // 110	8
U 9 SV // SL-SLX-300/6	3	2.2	60-260	64.9-11.1	90 // 110	8
U 9 SV // SL-SLX-400/7 T	4	3	60-260	76.7-14.3	90 // 110	14
U 9 SV // SL-SLX-450/8 T	4.5	3.31	60-260	89.5-19.7	90 // 110	14
U 9 SV // SL-SLX-500/9 T	5	3.7	60-260	100-21.9	90 // 110	14
U 9 SV // SL-SLX-550/10 T	5.5	4	60-260	112.8-26.5	90 // 110	14
U 18 SV // SL-SLX-250/3 T	2.5	1.85	100-440	31.1-7.5	90 // 110	8
U 18 SV // SL-SLX-400/4 T	4	3	100-440	45-11.2	90 // 110	8
U 18 SV // SL-SLX-400/5 T	4.5	3.31	100-440	54.3-14.3	90 // 110	8
U 18 SV // SL-SLX-500/6 T	5.5	4	100-440	66.4-19.3	90 // 110	8
U 18 SV // SL-SLX-750/8 T	7.5	5.5	100-440	90.9-42	90 // 110	14
U 18 SV // SL-SLX-900/9 T	9	6.6	100-440	101.8-46.1	90 // 110	14
U 18 SL-SLX-750/10 T	8.5	6.3	100-440	111.3-49	110	14
U 18 SL-SLX-900/11 T	10	7.5	100-440	125-56.8	110	14

GENERAL CONSTRUCTION CHARACTERISTICS



TYPE	P ²		Q (l/min)(m)	H (m)	Tmax (°C) water	P max (bar)
	Watt	KW				
DP 40	200		10-80	5.9-2.5	40	2
DP 60	400		20-120	8.1-2.6	40	2
DP 80	800		50-200	9.1-4	40	2
DPV 80	550		25-150	4.8-1.7	40	2
DP 100	1050		50-250	12.2-4.5	40	2
DPV 100	750		25-150	6.6-2.7	40	2
DX 80	1050		50-200	6.3-3.5	40	5
DX 100	1350		50-300	9-3.5	40	5
DG 80	1050		50-250	7.4-3.7	40	5
DG 100	1350		50-300	9.4-5.7	40	5
DH 80	980		50-250	14.9-4.3	40	5
DH 100	1370		50-300	18.5-4.4	40	5

TYPE	P ₂		Q (l/min)	H (m)	Tmax (°C) water	P max (bar)
	HPKW					
DV 150	1.5	1.1	100-650	7.8-2	40	8
DV 200	2	1.5	100-750	9.4-2	40	8
DVT 300	3	2.2	100-850	11.5-2	40	8
DVT 400	4	3	200-1300	19.4-2.8	40	8
DVT 550	5.5	4	200-1500	22.2-2.6	40	8
DVT 750	7.5	5.5	200-1800	22.7-2.8	40	8
DVT 1000	10	7.5	200-2000	25.2-2.6	40	8
DVT 250-4	2	1.5	200-1600	8.3-2.3	40	8
DVT 300-4	3	2.2	200-1800	9.6-2.4	40	8
DVT 400-4	4	3	200-2000	11.3-2.3	40	8
DVT 550-4	5.5	4.0	400-3000	12.2-2.6	40	8
DVT 750-4	7.5	5.5	400-3400	14.2-2.6	40	8
DM 160	1.5	1.1	100-900	15.3-3	40	8
DM 210	2	1.5	100-1000	18.4-3.4	40	8
DMT 310	3	2.2	100-1100	22.2-3.5	40	8
DMT 550	5.5	4	101-1300	24.9-4	40	8
DMT 1000	10.0	7.5	100-2400	32.6-2.1	40	8
DMT 250-4	2	1.5	200-1400	9.8-2.5	40	8
DMT 300-4	3	2.2	200-1500	10.9-3	40	8
DMT 400-4	4	3	200-1600	13-3.9	40	8
DMT 550-4	5.5	4.0	400-3000	13.6-1.7	40	8
DMT 750-4	7.5	5.5	400-3200	15.8-2.4	40	8
DC 160	1.5	1.1	100-600	17.9-3	40	8
DC 210	2	1.5	100-650	22.2-4.5	40	8
DCT 310	3	2.2	100-700	25.4-5.9	40	8
DCT 410	4	3	100-800	31.6-5.9	40	8
DCT 560	5.5	4	100-850	36.1-6.5	40	8
DCT 750	7.5	5.5	200-900	41.1-13.1	40	8
DCT 1000	10.0	7.5	200-900	48.9-22.6	40	8
DTR 150	1.5	1.1	50-300	18.5-9.9	40	8
DTR 200	2	1.5	50-300	21.2-13.4	40	8
DTRT 300	3	2.2	50-300	25.2-18.2	40	8
DTRT 400	4	3	50-300	31.8-21.6	40	8
DTRT 550	5.5	4	50-300	36.9-27.6	40	8
DTRT 750	7.5	5.5	50-300	46.2-36.1	40	8
DTRT 1000	10	7.5	50-300	52.7-42.7	40	8



INCLEDON

BLOEMFONTEIN	Tel: 051 408 9200	BURGERSFORT	Tel: 013 231 7224	GERMISTON	Tel: 011 323 0800	KATHU	Tel: 053 723 2213
KLERKSDORP	Tel: 018 469 4466	LEPHALALE	Tel: 014 763 5824	NELSPRUIT	Tel: 013 752 3121	NORTHRIDING	Tel: 011 462 7555
POLOKWANE	Tel: 015 292 8660	PRETORIA	Tel: 012 653 8520	SECUNDA	Tel: 017 631 4200	WELKOM	Tel: 057 396 1131
DURBAN	Tel: 031 716 2200	EAST LONDON	Tel: 043 736 6022	PORT ELIZABETH	Tel: 041 404 1800		

DPI TRADING (Western Cape)

CAPE TOWN	Tel: 021 957 5600	GEORGE	Tel: 044 874 2327
-----------	-------------------	--------	-------------------



D A W N
Member of the Dawn Group