

Rotary Seals

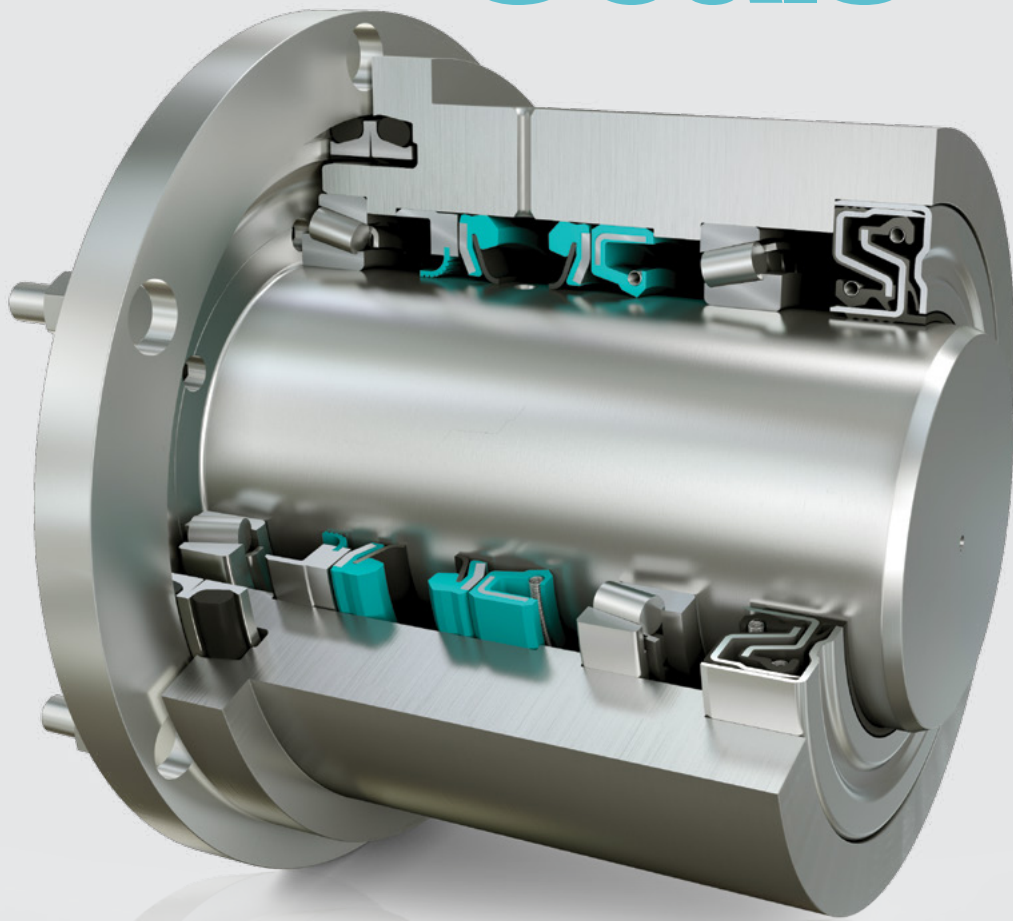



Your Partner for Sealing Technology

Trelleborg Sealing Solutions is a major international developer, manufacturer and supplier of seals, bearings and molded components in polymers. We are uniquely placed to offer dedicated design and development from our market-leading product and material portfolio: a one-stop-shop providing the best in elastomer, silicone, thermoplastic, PTFE and composite technologies for applications in aerospace, industrial and automotive industries.

With 50 years of experience, Trelleborg Sealing Solutions engineers support customers with design, prototyping, production, test and installation using state-of-the-art design tools. An international network of over 70 facilities worldwide includes over 20 manufacturing sites, strategically-positioned research and development centers, including materials and development laboratories and locations specializing in design and applications.

Developing and formulating materials in-house, we utilize the resource of our material database, including over 2,000

proprietary compounds and a range of unique products. Trelleborg Sealing Solutions fulfills challenging service requirements, supplying standard parts in volume or a single custom-manufactured component, through our integrated logistical support, which effectively delivers over 40,000 sealing products to customers worldwide.

Facilities are certified to ISO 9001:2008 and ISO/TS 16949:2009. Trelleborg Sealing Solutions is backed by the experience and resources of Trelleborg Group, one of the world's foremost experts in polymer technology.

ISO 9001:2008

ISO/TS 16949:2009

The information in this brochure is intended to be for general reference purposes only and is not intended to be a specific recommendation for any individual application. The application limits for pressure, temperature, speed and media given are maximum values determined in laboratory conditions. In application, due to the interaction of operating parameters, maximum values may not be achieved. It is vital therefore, that customers satisfy themselves as to the suitability of product and material for each of their individual applications. Any reliance on information is therefore at the user's own risk. In no event will Trelleborg Sealing Solutions be liable for any loss, damage, claim or expense directly or indirectly arising or resulting from the use of any information provided in this brochure. While every effort is made to ensure the accuracy of information contained herewith, Trelleborg Sealing Solutions cannot warrant the accuracy or completeness of information.

To obtain the best recommendation for a specific application, please contact your local Trelleborg Sealing Solutions marketing company.
This edition supersedes all previous brochures. This brochure or any part of it may not be reproduced without permission.

© All trademarks are the property of Trelleborg Group. The turquoise color is a registered trademark of Trelleborg Group. © 2018, Trelleborg Group. All rights reserved.

Contents

6	Introduction	81	Type TRQ – Medium-high Pressure Oil Seal
22	Overview Seal Design	83	Type HP20 – High Pressure Oil Seal
31	Radial Oil Seal	88	Type TRK – Medium Grease
33	General Seal Description	91	Type TRG – Medium Grease
35	Design Instructions: Shaft	94	Turbo Seals with Hydrodynamic Sealing Aids
37	Design Instructions: Housing Bore	96	Rotary and Axial Seal Combination
38	Material Recommendations	98	Type TRJ/TRL
41	Working Parameters		
47	Installation Instructions		
48	Standard Radial Oil Seal		
49	Type TRA		
57	Type TRE		
64	Type TRC		
67	Type TRD		
69	Type TRB		
73	Type TRF		
75	Non Standard Radial Oil Seals		
76	Type TRU – Medium Pressure Oil Seal		
79	Type TRP – Medium Pressure Oil Seal		
		113	Cassette Seal
		115	General Description
		115	System 500
		116	System 2000
		117	System 3000
		118	System 5000
		119	System CLS 1500
		122	Materials
		123	Application
		126	Installation
		128	Type APJ – Combined Oil Seal

131 End Covers

133 General Description

133 Type YJ 38

137 Type YJ 39

139 Shaft Repair Kit

141 General Description

143 Installation Recommendation – Metric Sizes

145 Installation Recommendation – Inch Sizes

149 Forsheda® V-Ring

151 General Description

152 Materials

155 Installation

158 V-Ring Type A

161 V-Ring Type S

163 V-Ring Type L/LX

166 V-Ring Type RM/RME

171 V-Ring Type AX

173 GAMMA Seal

175 General Description

179 Type TBP/RB

182 Type TBR/9RB

185 Turcon® Roto L

187 General Description

191 Turcon® Varilip® PDR

193 Introduction

194 Product Range

196 Materials

198 Operating Conditions

205 Design Guidelines

207 Installation Requirements

207 Packaging

207 Storage

208 Fitting Instructions

209 Installation Recommendations

210 Size Ranges

220 Ordering Information

221 Turcon® and Zurcon® Roto Seals**223 Turcon® Roto Glyd Ring®****235 Turcon® Roto Glyd Ring® K****247 Turcon® Roto Glyd Ring® V****261 Zurcon® Roto Glyd Ring® S****271 Turcon® Roto Variseal****281 Turcon® Roto VL Seal® F****295 Turcon® Roto VL Seal®****307 Installation Instructions****345 Storage Advice****347 General Quality Criteria****347 Guidelines for the Storage of Polymer Products
Based on ISO 2230**

**317 Turcon® Buffer Ring
with Back-pressure Relief**

327 Mechanical Face Seals**329 General Description****330 Applications****331 Materials****332 Design Instructions****332 Storage Conditions****332 Installation Instructions****336 Installation Recommendations for Type D0
in Bearing and Cast Iron Steel****342 Installation Recommendations for Type DF
Bearing Steel**

Welcome to Trelleborg Sealing Solutions

SEALING TECHNOLOGY

Trelleborg Sealing Solutions offers an outstandingly comprehensive sealing portfolio – a one-stop-shop providing the best in elastomer, silicone, thermoplastic, PTFE and composite technologies; solutions that feature in virtually every application conceivable within the aerospace, industrial and automotive industries.

A WORLDWIDE PRESENCE

We are uniquely placed to offer a dedicated design and development service for sealing solutions; globally servicing, supporting and supplying customers through an unrivaled international network.

COMMITMENT – TO CUSTOMERS, NEEDS LONG-TERM

Trelleborg Sealing Solutions is one of the world's foremost experts in polymer sealing technology. Using our expertise and experience, we facilitate customers in achieving cost-effective, durable solutions that match their specific business requirements.



For more information watch the Trelleborg movie on the Trelleborg website: www.tss.trelleborg.com

A world leader in engineered polymer solutions

THE TRELLEBORG GROUP



Trelleborg Coated Systems

Leading global supplier of unique customer solutions for polymer-coated fabrics deployed in a variety of industrial applications.



Trelleborg Industrial Solutions

Market leader in such industrial application areas as hose systems, industrial antivibration solutions and selected industrial sealing systems.



Trelleborg Offshore & Construction

Leading global supplier of polymer-based critical solutions for deployment in highly demanding environments.



Trelleborg Wheel Systems

Trelleborg Wheel Systems is a leading global supplier of tires and complete wheels for agricultural and forestry machines, materials handling and construction vehicles, and two-wheeled vehicles.



Trelleborg Sealing Solutions

One of the world's leading developers, manufacturers and suppliers of precision seals. It supports its aerospace, industrial and automotive customers through over 20 production facilities and more than 50 marketing companies globally.

THE BLUE DIMENSION™

At Trelleborg, we believe that the benefits of our solutions stretch beyond functionality and business performance. For more information visit <http://trelleborg.com/bluedimension>



Our Global Resources

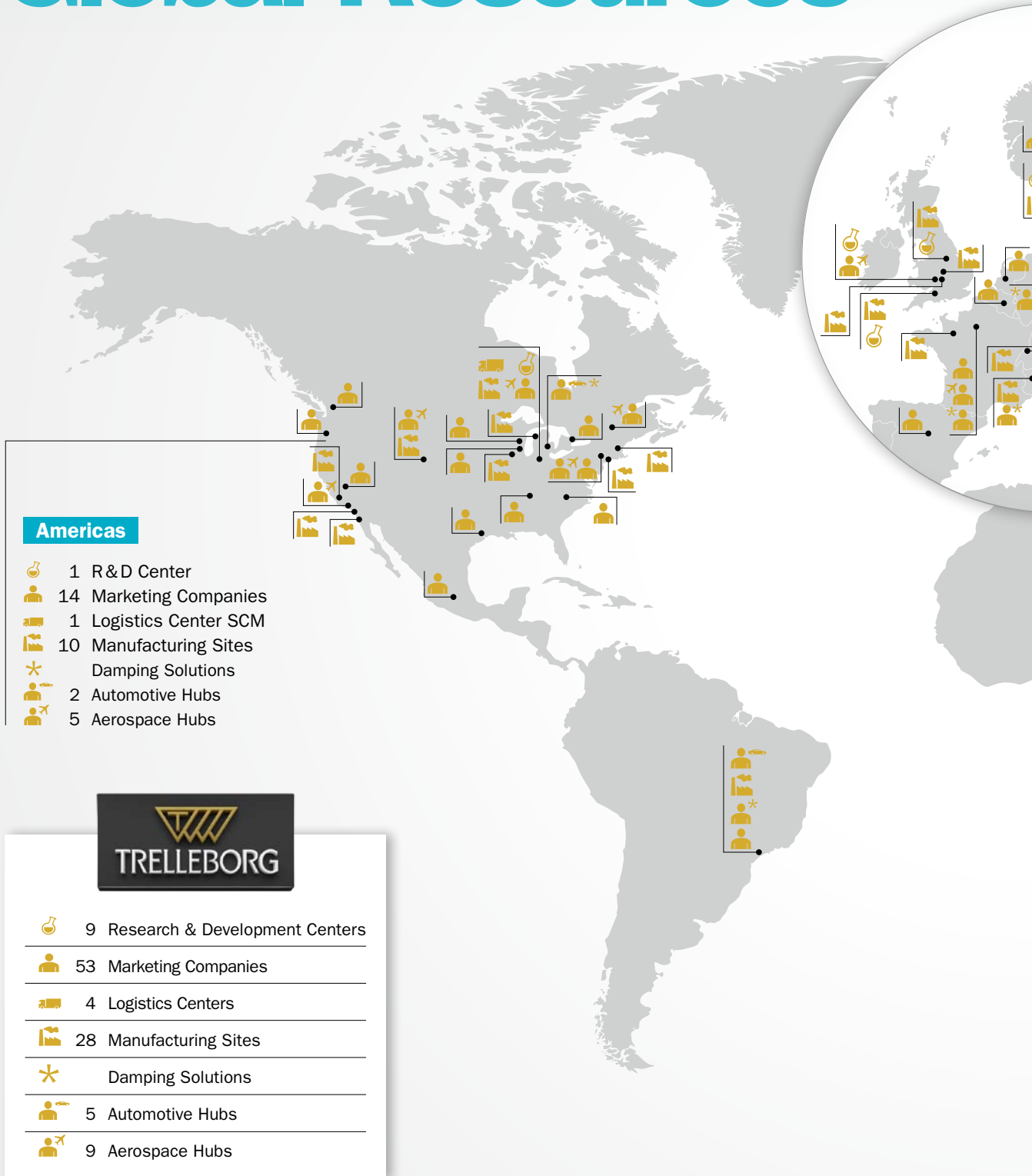

5,800
employees

82
worldwide
locations

More than
2,000
proprietary material
formulations

How local is your
global seal supplier?

www.global-but-local.com

Europe

-  7 R&D Centers
-  22 Marketing Companies
-  1 Logistics Center SCM
-  16 Manufacturing Sites
-  Damping Solutions
-  1 Automotive Hub
-  2 Aerospace Hubs

Asia

-  1 R&D Center
-  17 Marketing Companies
-  2 Logistics Centers SCM
-  2 Manufacturing Sites
-  Damping Solutions
-  2 Automotive Hubs
-  2 Aerospace Hubs

Products, Brands and Materials

Decades of experience designing and manufacturing polymer solutions has led Trelleborg Sealing Solutions to develop, manufacture and supply a range of unique materials and proprietary product designs, many of which have become industry standards. Development is ongoing, ensuring that our solutions meet the changing needs of our customers, as well as the latest industry trends and regulations.

WORLD RENOWNED NAMES UNITED

We own many of the longest established and leading names within the seal industry. These include:

- American Variseal
- Busak+Shamban
- Dowty Seals
- Chase Walton
- Forsheda
- GNL
- Impervia
- Nordex
- Orkot
- Palmer Chenard
- Polypac
- SSF
- SF Medical
- Shamban
- Silcofab
- Silcotech
- Skega
- Stefa
- Wills

PROPRIETARY MATERIALS

Ongoing development has yielded some of the most successful sealing and bearing materials available.

- HiMod®
- Isolast®
- Orkot®
- Turcite®
- Turcon®
- Turel®
- Zurcon®

OUR PIONEERING PRODUCTS

Trelleborg Sealing Solutions is pioneering and is continuously developing innovative products.

- Turcon® AQ Seal®
- D-A-S Compact Seal®
- Turcon® Double Delta®
- Turcon® Excluder®
- Turcon® Glyd Ring® T
- Turcon® Hatseal
- Zurcon® L-Cup®
- Turcite® Slydring®
- Turcite® B-Slydway®
- Turcon® Stepseal® 2K
- Turcon® Stepseal® V
- V-Ring®
- Turcon® Varilip® PDR
- Turcon® Variseal®
- Turcon® VL Seal®
- Turcon® Wedgpak®
- Wills Rings®
- Zurcon® Wynseal



To design a solution for your specific needs, contact your local Trelleborg Sealing Solutions marketing company.



Markets and Applications



Aerospace



Automotive

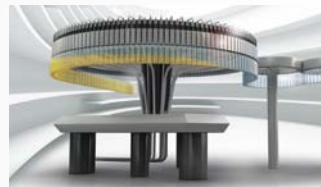

Food & Beverage



Chemical & Processing



Fluid Power - Hydraulics



Fluid Power - Pneumatics



Machine Tools



Alternative Energy



Healthcare & Medical



Agriculture



Construction vehicles



Semiconductor



Oil & Gas



Marine



Sanitary & Heating



Films and Animations

SEEING IS BELIEVING

Complex sealing configurations can feature a large number of sealing elements. Trying to illustrate these on a 2-D page is difficult and can never properly show their function or characteristics. Trelleborg Sealing Solutions turned to the latest graphic technologies to produce 3-D animations of applications and typical sealing solutions for them.

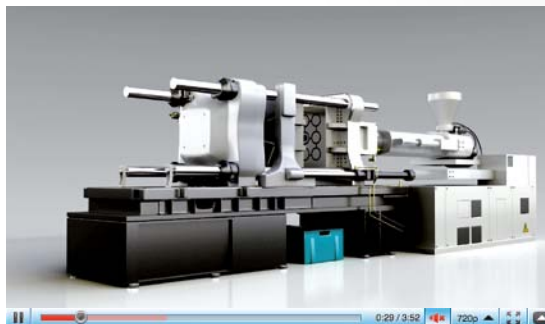

View at
[YouTube.com/
trelleborgseals](https://www.youtube.com/trelleborgseals)
YouTube



View at
[tss.trelleborg.com/
films](https://tss.trelleborg.com/films)
TSS



Online 24-7

A range of films specific to different industries and products are available to view on the Trelleborg Sealing Solutions website or via YouTube.



Simplify Your Business Service PLUS

Service PLUS aims at uniting various enhanced solutions across the entire value chain, simplifying the processes of engineering, logistics, manufacturing and aftermarket for the customer.



Engineering

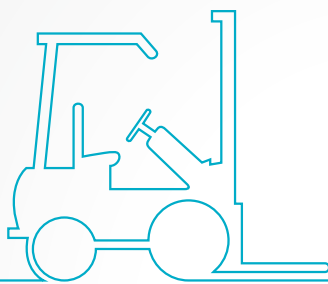

Logistics



Manufacturing

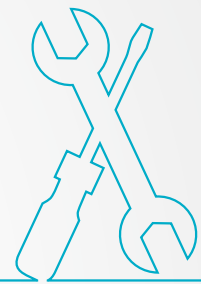

Aftermarket



SPECIAL HANDLING

Special Handling bundles an assortment of individual packaging solutions together with additional services that optimize the mounting and handling of seals.



ADVANCED DELIVERY

Our Advanced Delivery services simplify your stock replenishment process by managing your different vendors and stock levels – be it through a Kanban system or complete C-Part Management.



ENGINEERING SUPPORT SERVICES

Trelleborg provides world-class expert support for your engineering needs, from extensive design & compound competence to leading edge product testing.



ASSEMBLY

Trelleborg is willing and able to offer pre-assembled parts put together by specially trained staff, delivered directly to the customer.



QUICKSEAL

QuickSeal covers your short-notice needs for sealing solutions, whether you require a prototype, functional sample or a small batch rapidly.



DIGITAL TOOLS

Online resources and apps developed to make an engineer's life easier.

Discover our wide range of digital tools at www.tss.trelleborg.com





Digital Services

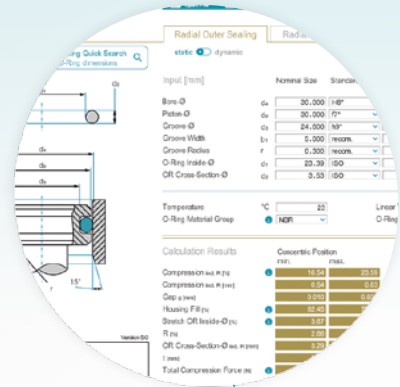

ONLINE TOOLS MAKE LIFE EASIER

Trelleborg Sealing Solutions has developed a number of online tools that make the working life of an engineer specifying seals easier. All these industry-leading tools are available free-of-charge from the Trelleborg Sealing Solutions website at www.tss.trelleborg.com. To use these advanced services all you have to do is register on the Members Area.

There is also a continually increasing range of innovative engineering apps available for smartphones, both for iOS and Android devices. Just search for "Trelleborg" in the App Store or GooglePlay to find the tools to optimize your daily productivity.

Materials Search and Chemical Compatibility Check

These two programs allow you to find out the compatibility of sealing materials with hundreds of different media and help identify the most suitable material for your application.

- + Very good suitability
- Good suitability
- Limited suitability
- ✗ Unsuitable
- ? Insufficient information



Versatile CAD Service

The CAD download facility provides thousands of drawings of a wide range of seals. It gives the option of 2- or 3-dimensional files in a range of formats to suit most commonly used CAD systems.

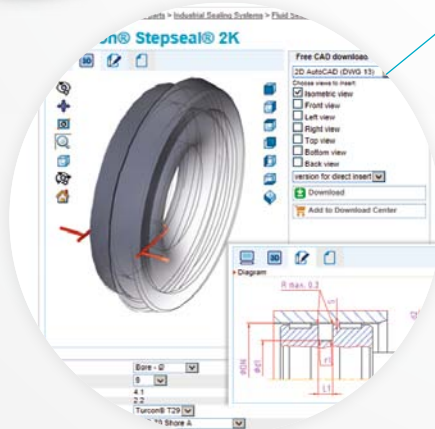



O-Ring Calculator

An industry-leading tool, the easy to use O-Ring calculator includes sizing capabilities, compression forces, design parameter recommendations and complete measurements. Results and comments may be printed, shared or filed as PDF.



Sealing Solutions Configurator

The Sealing Solutions Configurator is the first tool of its kind offered by any seal supplier. It allows engineers to identify a proven sealing solution for their specific application in just four easy steps.

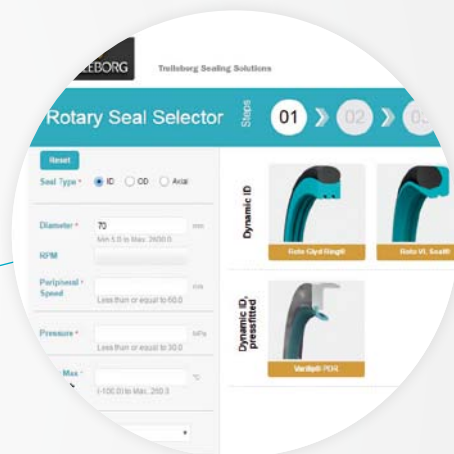

Rotary Seal Selector

The Rotary Seal Selector allows you to search through the wide range of rotary seals and materials available based on application conditions and offers detailed information on installation and seal capabilities.



4.0 Proposal Introduction

Dear Hilde Heens
Thank you for your call. We have had a look sealing solution to your application.

7.1.3 TSS Item No. and installation dimens

1. Turcite® / Zurcon® GR6901000-T47
 Slydring®
 Rod Diameter dN=100.0
 Groove Diameter D2=105.0
 Groove Width L2=6.7
 Turcite® Slydring® GR73A1000-C3
 Rod dN=100.0
 Groove D2=105.0

Technical Proposals Online

Enhance your communication with Trelleborg Sealing Solutions with the Technical Proposals Online tool. Instantly access all your proposed solutions anywhere at any time and benefit from quicker dialog with our sealing specialists.



For more information
www.tss.trelleborg.com

Mobile Apps and Services

We understand the needs of engineers on the go. Check out our latest mobile tools and apps, ranging from an O-Ring calculator to unit and hardness converters. Just search for "Trelleborg" in the App Store or Google Play to find the tools to optimize your daily productivity.

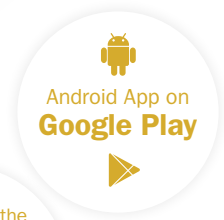

For more information
www.tss.trelleborg.com

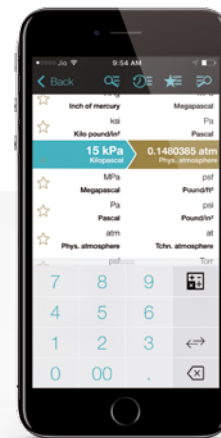
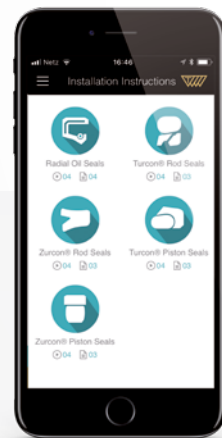
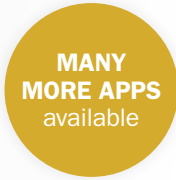

ISO Fits & Tolerances

Simply enter the nominal diameter and select the tolerance classes for bore and shaft to find the complete ISO fits definition with all relevant values including type of fit, with handy graphs to illustrate the classes by bore and shaft.



Technical Glossary

This app provides definitions of more than 2,000 terms from the world of sealing technology and engineering.



Aerospace Groove Selector

This app covers two of the most important SAE aerospace groove standards for hydraulic systems, AS4716 Rev B and AS5857 Rev A, making it really easy to find the size of grooves and hardware needed.



Installation Instructions

Videos demonstrate the best practice methods for installing seals, providing all relevant documentation within the interface, guiding you to a successful installation of Radial Oil Seals and Turcon® and Zurcon® rod and piston seals.



Unit & Hardness Converter

Intuitive and very easy to use, simply select the dimension and enter the value for conversion. The app offers a wide range of engineering and scientific units for each dimension.



in the groove

Our *in the groove* magazine provides news, technical and product information on seals, as well as insights into the markets they are used in. The magazine is also available in print and as an interactive PDF.



Rotary Selector

Bring the popular Rotary Seal Selector webtool with you! Quickly search through Trelleborg Sealing Solutions rotary seals and materials for the optimum product for your application conditions while on the move.



O-Ring Selector

When a user enters installation specifications into the O-Ring Selector app, such as the bore or rod/shaft diameter, the app quickly calculates O-Ring and housing dimensions in both metric and inch.

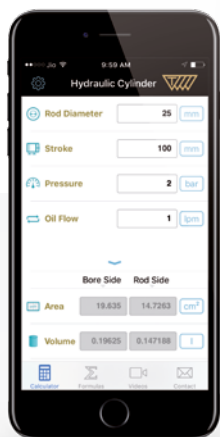

Hydraulic Cylinder Calculator

Quickly calculate areas and volumes in cylinders, extraction and retraction forces, time velocity and outflow by entering the requisite dimensions and parameters of the cylinder. In compliance with ISO 3320, ISO 3321 and ISO 4393.

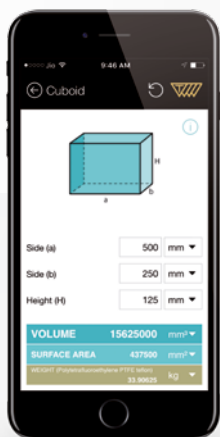

Area and Volume Calculator

Speeds up and simplifies calculating the area and volumes of more than 80 geometric shapes. The app supports both metric and imperial units and conveniently displays the formulas used. Fill your shape with solids or liquids, choosing from 1500 different materials, to calculate the weight.

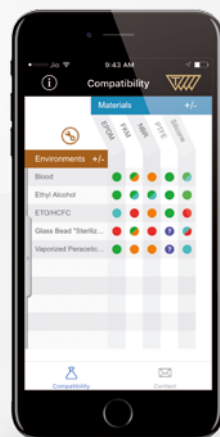

Healthcare Materials

View a quick and easy overview of the compatibility of 34 materials with 35 chemical environments that are commonly encountered in the healthcare and medical industries. Select up to 20 materials and environments at once to produce a chart rating each material from "excellent" to "not recommended".

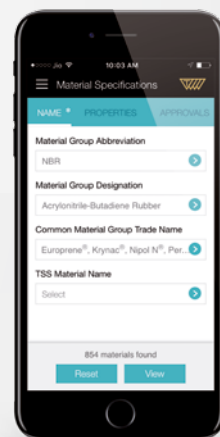













Sealing Materials Selector

Enter material specifications and required parameters, such as application temperature or hardness, to receive instant material proposals. The app features filters to limit searches based on chemical compatibility, institute approvals and product type and data sheets can be requested from within the interface.



■ Overview Seal Design

■ Radial Oil Seals

Family	Seal				Installation Size Range mm	Outer Cover		Dust lip		Technical Data*	
	Profile	Page	TSS Type	Standard (Characteristics)		Rubber Coated	Metal	With	Without	Speed m/s	Pressure MPa max.
Radial Oil Seals 		49	TRA	ISO 6194/1 DIN 3760 Type A	4 - 500	•		•		10	0.05
		57	TRE	ISO 6194/0 DIN 3760 Type AS	6 - 380	•		•		10	0.05
		64	TRC	ISO 6194/1 DIN 3761 Type B	6 - 550			•	•	10	0.05
		67	TRD	ISO 6194/1 DIN 3761 Type BS	15 - 400			•	•	10	0.05
		69	TRB	ISO 6194/1 DIN 3761 Type C	20 - 760			•	•	10	0.05
		73	TRF	ISO 6194/1 DIN 3761 Type CS	35 - 600			•	•	10	0.05
		76	TRU	Pressure seal	8 - 120	•		•		10	0.50
		79	TRP	Pressure seal	11 - 365	•		•		10	0.5
		81	TRQ	Pressure seal	15 - 55	•		•		5	1.0
		83	HP20	Very high pressure seal	17 - 72	•		•		4.7	20
		88	TRK	Low friction, no spring	4 - 70	•		•		10	Without







* The data below are maximum values and cannot be used at the same time. The maximum pressure depends on temperature.

■ Radial Oil Seals

Family	Seal				Installation Size Range mm	Outer Cover		Dust lip		Technical Data*	
	Profile	Page	TSS Type	Standard (Characteristics)		Rubber Coated	Metal	With	Without	Speed m/s	Pressure MPa max.
Radial Oil Seals		91	TRG	Low friction, no spring	4 - 70		•		•	10	Without
	 	98	TRJ/TRL	Fabric reinforced	100 - 1,954	•			•	10	0.05

* The data below are maximum values and cannot be used at the same time. The maximum pressure depends on temperature.

■ Cassette Seal

Family	Seal				Installation Size Range mm	Outer Cover		Dust lip		Technical Data*	
	Profile	Page	TSS Type	Standard (Characteristics)		Rubber Coated	Metal	With	Without	Speed m/s	Pressure MPa max.
Cassette Seals		115	TC5	System 500	90 - 320		•			10	0.05
		116	TC2	System 2000	143 - 160		•			5	0.05
		117	TC3	System 3000	130 - 190		•	•		4	0.05
	 	118	TC0	System 5000	On demand		•	•		15	0.05
		119	TCY	CLS 1500	On demand		•	•		4	0.05
		128	TCY	APJ Cassette	On demand	•	•	•		10	0.05

* The data below are maximum values and cannot be used at the same time. The maximum pressure depends on temperature.

■ End Covers

Family	Seal				Installation	Outer Cover		Dust lip		Technical Data*	
	Profile	Page	TSS Type	Standard (Characteristics)	Size Range mm	Rubber Coated	Metal	With	Without	Speed m/s	Pressure MPa max.
End Covers		133	YJ 38	End cover	16 - 230	•					0.05
		137	YJ 39	End cover	22 - 270	Half	Half				0.5









* The data below are maximum values and cannot be used at the same time. The maximum pressure depends on temperature.

■ Shaft Repair

Family	Seal				Installation	Outer Cover		Dust lip		Technical Data*	
	Profile	Page	TSS Type	Standard (Characteristics)	Size Range mm	Rubber Coated	Metal	With	Without	Speed m/s	Pressure MPa max.
Shaft Repair		141	TS	Sleeve	12 - 200		•				

* The data below are maximum values and cannot be used at the same time. The maximum pressure depends on temperature.

■ V-Rings

Family	Seal					Installation Size Range mm	Retention/ Clamping Possibilities		Technical Data*	
	Profile	Page	TSS Designation	FORSHEDA-Type	Standard (Characteristics)		With Clamping Band	With Axial Retention	Speed m/s	Pressure MPa max.
V-Ring 		158	VA	A	V-Ring Standard	2.7 - 2,010		•	10	Without
		161	VS	S	V-Ring Extended body	4.5 - 210		•	10	Without
		163	VL	L	V-Ring Small profile	105 - 2,025		•	10	Without
		163	LX	LX	V-Ring Large diameter rigid lip	135 - 2,025		•	10	Without
		166	RM	RM	V-Ring Standard with clamping band, extended body	300 - 2,010	•		10	Without
		166	RME	RME	V-Ring Standard with clamping band	300 - 2,010	•		10	Without
		171	AX	AX	V-Ring Large diameter, flexible lip	200 - 2,020		•	10	Without



* The data below are maximum values and cannot be used at the same time. The maximum pressure depends on temperature.

■ GAMMA Seals

Family	Seal				Installation Size Range mm	Technical Data*	
	Profile	Page	TSS Type	Material		Speed m/s	Pressure MPa max.
GAMMA Seals 		179	TBP	Gamma seal standard	10 - 225	20	Without
		182	TBR	Gamma seal with labyrinth	15-108	20	Without



* The data below are maximum values and cannot be used at the same time. The maximum pressure depends on temperature.

■ Turcon® Roto L

Family	Seal				Installation Size Range mm	Technical Data*	
	Profile	Page	TSS Type	Material		Speed m/s	Pressure MPa max.
Turcon® Roto L 		187	TT	M12/M83	10 - 350	20	1.0

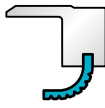

* The values given are maximums. Maximum values should not be combined. The maximum pressure depends on temperature.

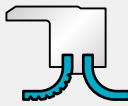
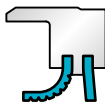
■ Turcon® Varilip® PDR

Family	Seal				Installation Size Range mm	Technical Data*	
	Profile	Page	TSS Type	Standard (Characteristics)		Speed m/s	Pressure MPa max.
Turcon® Varilip® PDR 		194	A	For use with pressure from one side. Use in applications with high speed or poor lubrication or when low friction is required.	Shaft sizes 6 mm to 170 mm as standard for all types.	60	0.5
		194	B	Use for pressure from one side as type A, but with a secondary redundant sealing element incorporated for additional sealing safety.		40	0.5
		194	C	Used in higher pressure applications. Pressure is from one side only.		20	1.0
		194	D	Double sealing arrangement to seal media from both sides.		40	0.5
		194	G	Single-acting seal to work with media from one side but with the addition of a dirt excluder on the environment side. The excluder lip is a transition contact only to reduce friction.		60	0.5



* Speeds up to 90 m/s can be achieved with detailed application analysis and custom designs. Please consult your local Trelleborg Sealing Solutions marketing company.

Turcon® Rotary and Zurcon® Roto Seals

Family	Seal		Application	Standard	Size Range	Function		Technical Data*			Material	Shaft
	Type	Page				Field of Application	ISO/DIN	mm	Single-acting	Double-acting		
Turcon® Roto Glyd Ring®  I.S. = Inner Sealing O.S. = Outer Sealing	Turcon® Roto Glyd Ring® I.S.	223	Rotary distributors Pivoting motors: Mobile hydraulic Machine tools	ISO 7425/2	6 - 2,600	•	•	-45 to +200	1	30	Turcon® T10	> 55 HRc
									2	20	Turcon® T40	> 55 HRc
	Turcon® Roto Glyd Ring® O.S.	223	Rotary distributors Pivoting motors: Mobile hydraulic Machine tools	ISO 7425/1	8 - 2,700	•	•	-45 to +200	1	30	Turcon® T10	> 55 HRc
									2	20	Turcon® T40	> 55 HRc
Turcon® Roto Glyd Ring® K  I.S. = Inner Sealing O.S. = Outer Sealing	Turcon® Roto Glyd Ring® K I.S.	235	For end caps of rotary distributors and unions: High pressure valve stems Manipulators Hydraulic motors Pivoting motors in mobile hydraulic and machine tools		20 - 900	•	•	-100 to +200	0.2	30	Turcon® T40	> 55 HRc
									0.2	25	Turcon® M15	> 55 HRc
	Turcon® Roto Glyd Ring® K O.S.								0.2	30	Zurcon® Z80	> 55 HRc



* The data below are maximum values and cannot be used at the same time. The maximum pressure depends on temperature.

** Temperature range depends on choice of elastomer material.

Family	Seal		Application	Standard	Size Range	Function		Technical Data*			Material	Shaft
	Type	Page				Field of Application	ISO/DIN	mm	Single-acting	Double-acting		
Roto Glyd Ring® V 	Turcon® Roto Glyd Ring® V I.S.	247	For sealing shafts, axels Machine tools Rotary distributors Valve spindles Hydraulic rotator Robotics		35 - 500							
	I.S. = Inner Sealing											
O.S. = Outer Sealing	Turcon® Roto Glyd Ring® V O.S.	247	For sealing cylinder bores Machine tools Hydraulic swivels Robotics		22 - 500							
Zurcon® Roto Glyd Ring® S 	Zurcon® Roto Glyd Ring® I.S.	261	For sealing shafts, axles and rotary transmission leadthroughs with slow rotary or oscillating movement.	ISO 7425/2	10 - 2,200							
	I.S. = Inner Sealing											
O.S. = Outer Sealing	Zurcon® Roto Glyd Ring® O.S.	261		ISO 7425/1	10 - 2,300							
Turcon® Roto Variseal® 	Turcon® Roto Variseal®	271	Rotary distributors Pivoting motors: - Pharmaceuticals - Machine tools - Foodstuffs - Industrial - Chemical		5 - 2,500							

* The data below are maximum values and cannot be used at the same time. The maximum pressure depends on temperature.

** Temperature range depends on choice of elastomer material.

Family	Seal		Application	Standard	Size Range	Function		Technical Data*			Material	Shaft
	Type	Page				Field of Application	ISO/DIN	mm	Single-acting	Double-acting		
Turcon® Roto VL Seal®	Turcon® Roto VL Seal® F I.S.	281	For sealing shafts, axels Machine tools Rotary distributors Injection moulding machines Valve spindles Hydraulic steering units Hydraulic rotator Robotics Bearing grease		6 - 2,600						Turcon® M15 T40	> 55 HRc
			For sealing cylinder bores Machine tools Hydraulic swivels Robotics Bearing grease		14 - 2,700							
I.S. = Inner Sealing O.S. = Outer Sealing	Turcon® Roto VL Seal® I.S.	295	For sealing shafts, axels Machine tools Rotary distributors Injection moulding machines Valve spindles Hydraulic steering units Hydraulic rotator Robotics Bearing grease	ISO 6194	6 - 2,600						Turcon® M15 T40 Zurcon® Z80	> 55 HRc
			For sealing cylinder bores Machine tools Hydraulic swivels Robotics Bearing grease		10 - 2,700							

* The data below are maximum values and cannot be used at the same time. The maximum pressure depends on temperature.

** Temperature range depends on choice of elastomer material.

Turcon® Buffer Ring with Back-pressure Relief

Family	Seal		Application	Standard	Size Range	Function		Technical Data*			Material	Shaft
	Type	Page				Field of Application	ISO/DIN	mm	Single-acting	Double-acting		
Turcon® Buffer Ring 	Turcon® Buffer Ring I.S.	319	Rotary injection molding unit Rotary distributors Peak pressure protection For high pressure low sealing		4 - 2,600	·		-45 to +70	15	30	Turcon® M15 T40 Zurcon® Z53	> 55 HRc
	Turcon® Buffer Ring O.S.				8 - 2,700			+5 to +160				

* The data below are maximum values and cannot be used at the same time. The maximum pressure depends on temperature.

** Temperature range depends on choice of elastomer material.

Mechanical Face Seals

Family	Seal				Installation Size Range mm	Technical Data*	
	Profile	Page	TSS Type	Material		Speed m/s	Pressure MPa max.
Mechanical Face Seals 		336	TLDO	100cr6	45 - 886	2.2	0.15
				Cast iron	51 - 457	3.0	0.15
		342	TLDF	100cr6	59 - 492	3.0	0

* The values given are maximums. Maximum values should not be combined. The maximum pressure depends on temperature.

Radial Oil Seal







■ Radial Oil Seal

■ General Seal Description

GENERAL

Radial Oil Seals, also known as rotary shaft lip seals, are round sealing devices used to seal between two machine parts that rotate relative to each other. They are used to seal lubrication in and/or contamination out, or to separate dissimilar media.

SEAL DESIGN

Although there are many styles of Radial Oil Seal, they all generally consist of a flexible rubber lip bonded to a rigid metal case. Most also contain a third element - a garter spring - fitted into the rubber lip to provide additional sealing force, both

initially and over the life of the seal. The total radial force of the sealing lip is a function of the rubber pre-tension, coupled with the tensile spring force. The sealing lip may be lathe cut or ready molded, and may feature molded-in hydrodynamic aids to assist sealing in demanding applications. The metal case may be exposed or have rubber molded around it for ease of assembly or improved static sealing.

Trelleborg Sealing Solutions offers state-of-the-art Radial Oil Seal design standards based on many years of experience in a wide range of application fields.

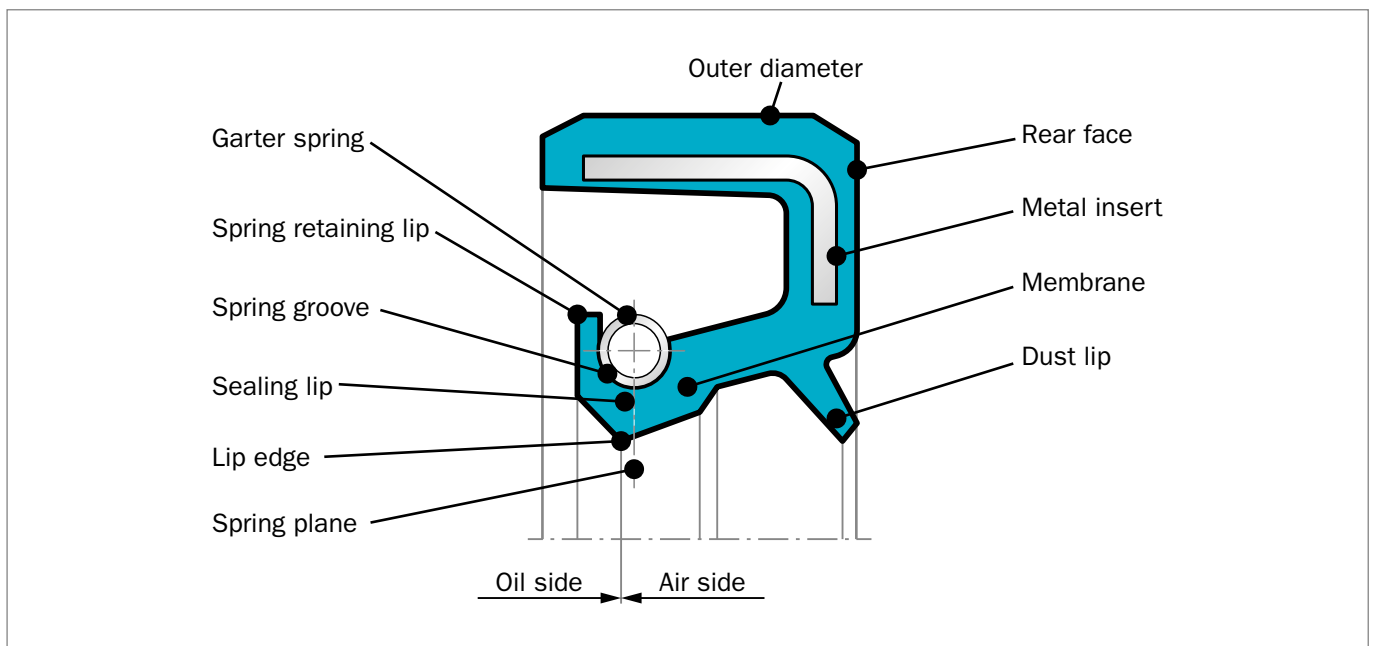

Figure 1: Designation for Rotary shaft lip seals (extract from ISO 6194)



METAL CASE

The metal case is normally made out of formed, cold-rolled steel sheet in accordance with DIN EN 10139. Another material, such as stainless steel or brass may be used, depending on application requirements. If the metal case is rubber-covered, the outside diameter may be either smooth or ribbed. In all cases, the seal outer diameter tolerance is in accordance with ISO 6194-1 and the bore tolerance is in accordance with ISO H8.

Table 1: Tolerance according ISO 6194-1

Nominal Outside Diameter d_2	Diametral Tolerance	
	Metal Cased	Rubber Covered
$D_2 \leq 50$	+0.20	+0.30
	+0.08	+0.15
$50 < D_2 \leq 80$	+0.23	+0.35
	+0.09	+0.20
$80 < D_2 \leq 120$	+0.25	+0.35
	+0.10	+0.20
$120 < D_2 \leq 180$	+0.28	+0.45
	+0.12	+0.25
$180 < D_2 \leq 300$	+0.35	+0.45
	+0.15	+0.25
$300 < D_2 \leq 530$	+0.45	+0.55
	+0.20	+0.30

Note: Ribbed O.D tolerances on request.

GARTER SPRING

Function

When rubber is exposed to heat, pressure or chemical attack, it will gradually lose its original properties. The rubber is then said to have aged, causing the original radial force exerted by the sealing element to diminish. The function of the garter spring is to maintain the radial force during this period.

Experiments have shown that the radial force must vary with the size and type of seal. They have also clearly indicated the significance of maintaining the radial force within narrow limits during the service life of the seal. Extensive investigations in the laboratory have formed the basis for defining the radial force.

The garter spring is closely wound and carries an initial tension. The total force exerted by the spring consists of the force required to overcome the initial tension and the force due to the spring rate. The use of a garter spring with initial tension ensures that, as the sealing element wears, the total radial force from the initial tension will not change.

Material

Spring steel is normally used. If resistance to corrosion is required, stainless steel can be substituted. Garter springs of bronze or similar materials are not recommended, since they tend to fatigue after long service life, or as a result of exposure to high temperatures. In special cases, the garter spring can be protected against damage by means of a thin rubber cover.



■ Design Instructions: Shaft

SURFACE FINISH, HARDNESS AND MACHINING METHODS

The shaft design is vital for the sealing performance and ensures the maximum useful life of the seal (see Figure 4). As a basic principle, the hardness of the shaft should be higher as peripheral speeds increase. The Standard DIN 3760 specifies that the shaft must be hardened to at least 45 HRC.

As the peripheral speeds increase, the hardness must be increased, and at 10 m/s a hardness of 60 HRC is required. The choice of a suitable hardness is dependent not only on the peripheral speed but also on such factors as lubrication and the presence of abrasive particles. Poor lubrication and difficult environmental conditions require a higher shaft hardness. DIN 3760 specifies a surface roughness of Ra 0.2 - Ra 0.8 μm . Laboratory tests have however proved that the most suitable roughness is $R_t = 2 \mu\text{m}$ ($R_a = 0.3 \mu\text{m}$). Rougher as well as smoother surfaces generate higher friction, resulting in increased temperature and wear. Trelleborg Sealing Solutions suggest a surface roughness of Ra 0.2 - 0.5 μm .

Measurements of friction and temperature have also shown that grinding of the shaft is the best method of machining. However, spiral grinding marks may cause a pumping effect. Therefore, plunge grinding should be used, during which even ratios between grinding wheel speed and work-piece should be avoided. Polishing of the shaft surface with a polishing cloth produces a surface which causes higher friction and increases heat generated when compared with plunge grinding. In certain cases it may be impossible to provide the necessary hardness, surface finish and corrosion resistance of the shaft. This problem can be solved by fitting a separate sleeve onto the shaft. If wear should occur, only the sleeve needs to be replaced (see information on Trelleborg Sealing Solutions "Shaft Repair Kit").

SHAFT RUN OUT

Shaft run out should as far as possible be avoided or kept within a minimum. At higher speeds there is a risk that the inertia of the sealing lip prevents it from following the shaft movement. The seal must be located next to the bearing and the bearing play should be maintained at the minimum value possible (see Figure 2).

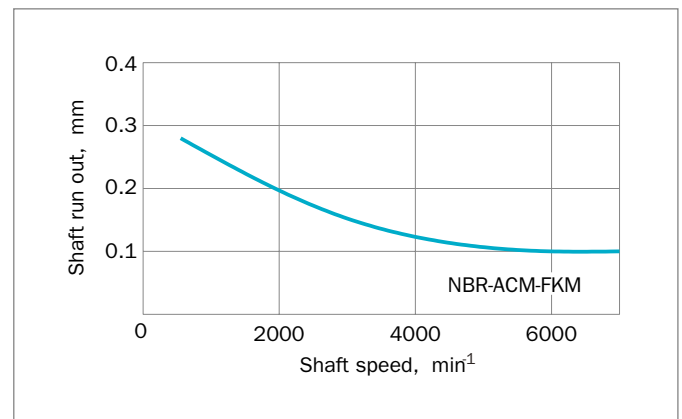

Figure 2: Shaft run out

ECCENTRICITY

Eccentricity between shaft and housing bore centers should be avoided in order to eliminate unilateral load of the lip (see Figure 3).

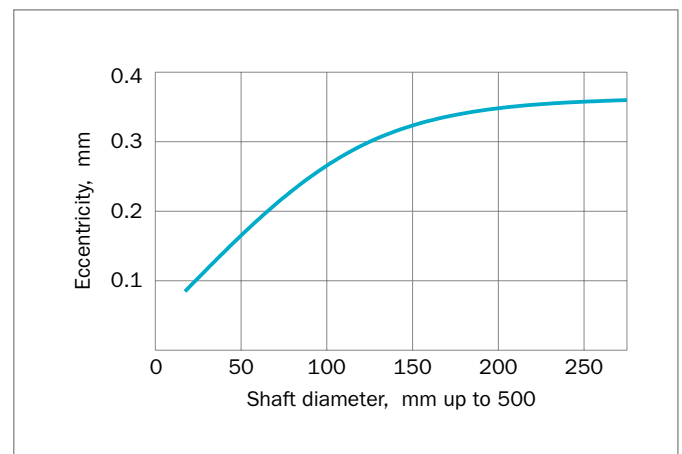

Figure 3: Eccentricity

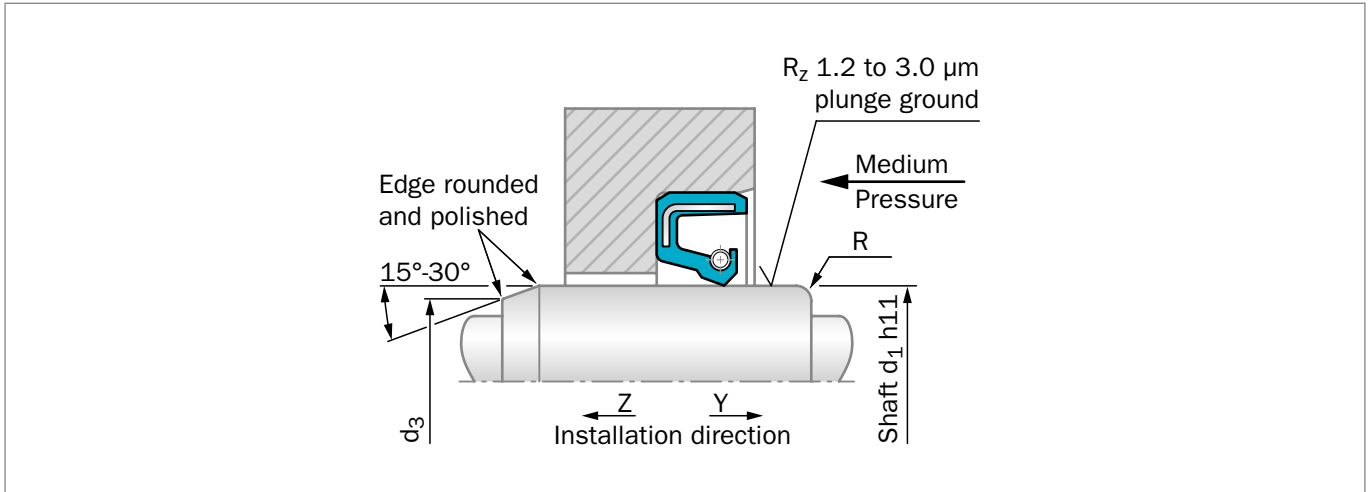

Figure 4: Installation of the Radial Oil Seal

Depending on the installation direction (Y or Z), a chamfer or radius on the shaft is recommended. The dimensions for this are shown in Figure 4 and Table 2.

Table 2: Chamfer Length for Shaft End

d_1	d_3	R
< 10	d1 - 1.5	2
over 10 to 20	d1 - 2.0	2
over 20 to 30	d1 - 2.5	3
over 30 to 40	d1 - 3.0	3
over 40 to 50	d1 - 3.5	4
over 50 to 70	d1 - 4.0	4
over 70 to 95	d1 - 4.5	5
over 95 to 130	d1 - 5.5	6
over 130 to 240	d1 - 7.0	8
over 240 to 480	d1 - 11.0	12

CHARACTERISTICS OF THE SHAFT SURFACE

The running surface for oil seals is specified in DIN 3760/61. The surface should meet the following requirements:

Hardness:	55 HRC or 600 HV, hardness depth min. 0.3 mm
Surface roughness:	$R_a = 0.2$ to $0.5 \mu\text{m}$ $R_z = 1.2$ to $3.0 \mu\text{m}$ $R_{mr} = 50-70\%$, $c = 0.25 \times R_z$

SURFACE ROUGHNESS

The functional reliability and service life of a seal depends to a very great extent on the quality and surface finish of the mating surface to be sealed. Scores, scratches, pores and concentric or spiral machining marks are not permitted. Higher demands must be made on the surface finish of dynamic mating surfaces than on static mating surfaces. Plunge grinding is recommended to eliminate the presence of helical "lead" on the shaft.

The characteristics most frequently used to describe the surface microfinish, R_a , R_z and R_{max} , are defined in ISO 4287. These characteristics alone, however, are not sufficient for assessing the suitability in seal engineering. In addition, the material contact area R_{mr} in accordance with ISO 4287 should be considered. The significance of these surface specifications is illustrated in Figure 5. It shows clearly that specification of R_a or R_z alone does not describe the profile form accurately enough and is thus not sufficient for assessing suitability in seal engineering.

The material contact area R_{mr} is essential for assessing surfaces, as this parameter is determined by the specific profile form. This in term is directly depending on the machining process employed.

Surface profile	R_a	R_z	R_{mr}
closed profile form 	0.1	1.0	70%
open profile form 	0.2	1.0	15%

Figure 5: Examples of various surface profile parameters



■ Design Instructions: Housing Bore

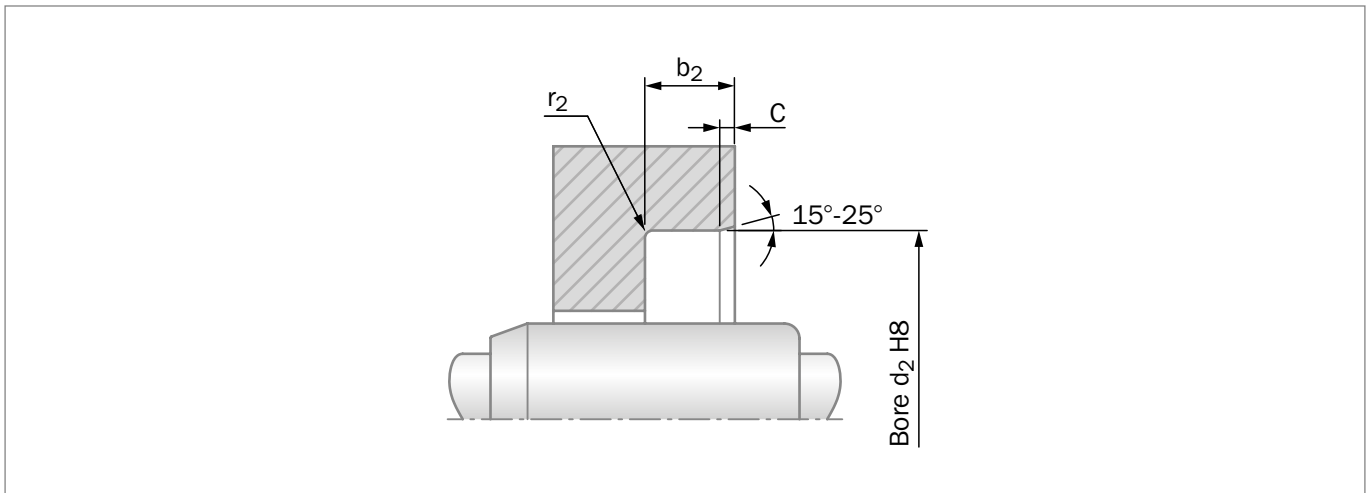

Figure 6: Installation depth and lead-in chamfer

HOUSING BORE

For metric sizes, the tolerances are in accordance with the ISO 6194-1 which provides a suitable press fit for the bore tolerance ISO H8. The inch sizes are in accordance with American Standards. In cases where the housing bore has a different tolerance, the seal can be made to a suitable size. For bearing housings made of soft materials, e.g. light metals, and for bearing housings with thin walls, a special fit between the seal and the housing may be necessary. The tolerances for the seal and housing should then be determined by practical assembly trials. If a component such as a bearing is assembled through the housing bore for the seal, the bore may be damaged. In order to avoid damaging the bore, a seal with a larger outside diameter than that of the bearing should be selected.

Table 3: Housing Dimensions

Ring Width b	C mm	b ₂ (b + 0.3) mm	r ₂ max.
7	0.7 to 1.0	8.2	0.5
8	0.7 to 1.0	9.2	0.5
10	0.7 to 1.0	11.2	0.5
12	1.0 to 1.3	13.5	0.75
15	1.0 to 1.3	16.5	0.75
20	1.0 to 1.3	21.5	0.75

SURFACE ROUGHNESS OF THE HOUSING

Values for the surface roughness in the gland are specified in ISO 6194/1.

General values: $R_a = 1.6 - 3.2 \mu\text{m}$
 $R_z = 6.3 - 12.5 \mu\text{m}$

For metal-to-metal sealing or gas sealing, a good score-free and spiral-free surface finish is necessary. If the rotary shaft lip seal is bonded into the housing, ensure that no adhesive comes into contact with the sealing lip or the shaft.



SEALING ELEMENT

Compound

The material selected must take into account environmental conditions and function requirements.

Some of the requirements associated with environmental considerations are:

- Good chemical resistance
- Good resistance to heat and low temperature
- Good resistance to ozone and weathering

The functional demands include:

- High resistance to wear
- Low friction
- Low compression set
- Good elasticity

In addition, cost considerations render ease of processing a desirable feature. For the optimum material recommendation

Table 4: Material Recommendations

Materials for Sealing Common Media		Material Designation			
		Acrylonitrile Butadiene Rubber NBR	Fluorocarbon Rubber FKM	Polyacrylate Rubber ACM	Hydrogenated Acrylonitrile Butadiene Rubber HNBR
		Material Abbreviation			
		N	V	A	H
		Max. Permissible Constant Temperature (°C)			
Mineral fluids	Engine oils	100	170	125	130
	Transmission oils	80	150	125	110
	Hypoid transmission oils	80	150	125	110
	ATF oils	100	170	125	130
	Hydraulic fluids (DIN 51524)	90	150	120	130
	Greases	90	-	-	100
Flame retardant hydraulic fluids (VDMA 24317) (VDMA 24320)	Oil-water emulsion	70	-	-	70
	Water-oil emulsion	70	-	-	70
	Aqueous solutions	70	-	-	70
	Water-free fluids	-	150	-	-
Other media	Fuel oils	90	-	-	100
	Water	90	100	-	100
	Lyes	90	100	-	100
	Air	100	200	150	130

Due to the different configurations of the media, the above-mentioned temperature ranges are for guidance only. Depending on the media, significant deviations may occur.

for your application, contact your local Trelleborg Sealing Solutions marketing company.

Type and Designations of Materials

Nitrile rubber	(NBR)
Acrylic rubber	(ACM)
Fluorinated rubber	(FKM)
Hydrogenated Nitrile rubber	(HNBR)

In order to satisfy the wide range of demands made on seals, Trelleborg Sealing Solutions has developed special unique compounds of each type of rubber. Other compounds are also available to meet extreme requirements.



■ Description of Rubber Materials

NITRILE RUBBER (NBR)

Advantages:

- Good oil resistance
- Good heat resistance up to +100 °C in oil
- High tensile strength (special compounds over 20 MPa)
- High elongation at break
- Low swelling in water

Limitations:

- Poor weather and ozone resistance
- Poor resistance against polar fluids (ester, ether, ketones and aniline)
- Poor resistance against chlorinated hydrocarbons (carbon tetrachloride, trichlorethylene)
- Poor resistance against aromatic fluids (e.g. benzene, toluene)

Fluids, mineral oils and, above all, high-alloyed mineral oils (hypoid oils) containing larger quantities of aromatic hydrocarbons have a high swelling effect on NBR compounds. The swelling behavior can be improved by increasing the acrylonitrile content.

However an inferior cold flexibility and resistance to compression set must be accepted. The additives in high-alloyed oils can in certain cases cause an additional interaction between the elastomer and the additive, thus influencing the elasticity.

HYDROGENATED NITRILE RUBBER (HNBR)

Advantages:

- Good oil resistance, also in hypoid oils
- Good heat resistance, up to +150 °C
- Good mechanical properties
- Good weather and ozone resistance

Limitations:

- Poor resistance against polar fluids (esters, ethers, ketones and aniline)
- Poor resistance against chlorinated hydrocarbons (carbon tetrachloride, trichlorethylene)
- Poor resistance against aromatic fluids (benzene, toluene)

POLYACRYLIC RUBBER (ACM)

Advantages:

- Good resistance against oils and fuels (better than Nitrile rubber)
- Heat resistance about +50 °C better than for Nitrile rubber, +150 °C in oil and +125 °C in air
- Good weather and ozone resistance

Limitations:

- Not usable in contact with water and water solutions, even smaller quantities of water in oil
- Limited cold flexibility to about -20 °C, somewhat poorer than normal NBR
- Limited tensile strength and tear resistance, especially above +100 °C
- Poor wear resistance (considerably inferior compared to NBR)
- Poor resistance against polar and aromatic fluids and chlorinated hydrocarbons

FLUORINATED RUBBER (FKM)

Advantages:

- The resistance against oils and fuels is better than for any other rubber type
- The only highly elastic rubber material, which is resistant to aromatic and chlorinated hydrocarbons
- Excellent heat resistance, up to +200 °C
- Excellent weather and ozone resistance
- Excellent acid resistance (only inorganic acids, not suitable for organic acids e.g. acetic acid)

Limitations:

- Limited cold flexibility, to approximately +20 °C to -25 °C
- Limited tensile and tear strength, especially above +100 °C
- High compression set in hot water
- Poor resistance to polar solvents



FLUROSILICONE (FVMQ)

Advantages:

- Very low temperature flexibility down to -60 °C
- Excellent heat resistance, up to +230 °C
- Good compatibility with most mineral oils

Advantages:

- Expensive material
- Not suitable with polar fluids

FDA-COMPOUNDS

Trelleborg Sealing Solutions has engineered a set of compounds suitable to be used in rotary sealing applications like gearboxes, mixers and other equipment requiring a separation between lubricants and food or any external chemicals.

The elastomeric lip is energized by a spring and can be designed like any Radial Oil Seal in order to effectively work under pressure, with shaft eccentricities and vibrations, with axial play.

Available types of compounds are updated according to state of the art regulations like the FDA. Most available Radial Oil Seals are molded from EPDM and FKM polymers, bonded to stainless steel metal inserts and energized with special INOX springs. The engineering of these items is usually made according to customer specifications.



■ Working Parameters

TEMPERATURE RESISTANCE

Increasing temperature accelerates the aging of the rubber, the material becomes hard and brittle, the elongation decreases and the compression set increases. Axial cracks at the sealing edge are a typical indication that the seal has been exposed to excessively high temperature.

The aging of the rubber has appreciable significance on the useful life of the seal. The temperature limits for the principal materials are illustrated in Figure 7. They should only be regarded as approximate, since the materials are also affected by contact media. It can generally be said that a temperature increase of +10 °C (in air) will halve the theoretical useful life of the rubber.

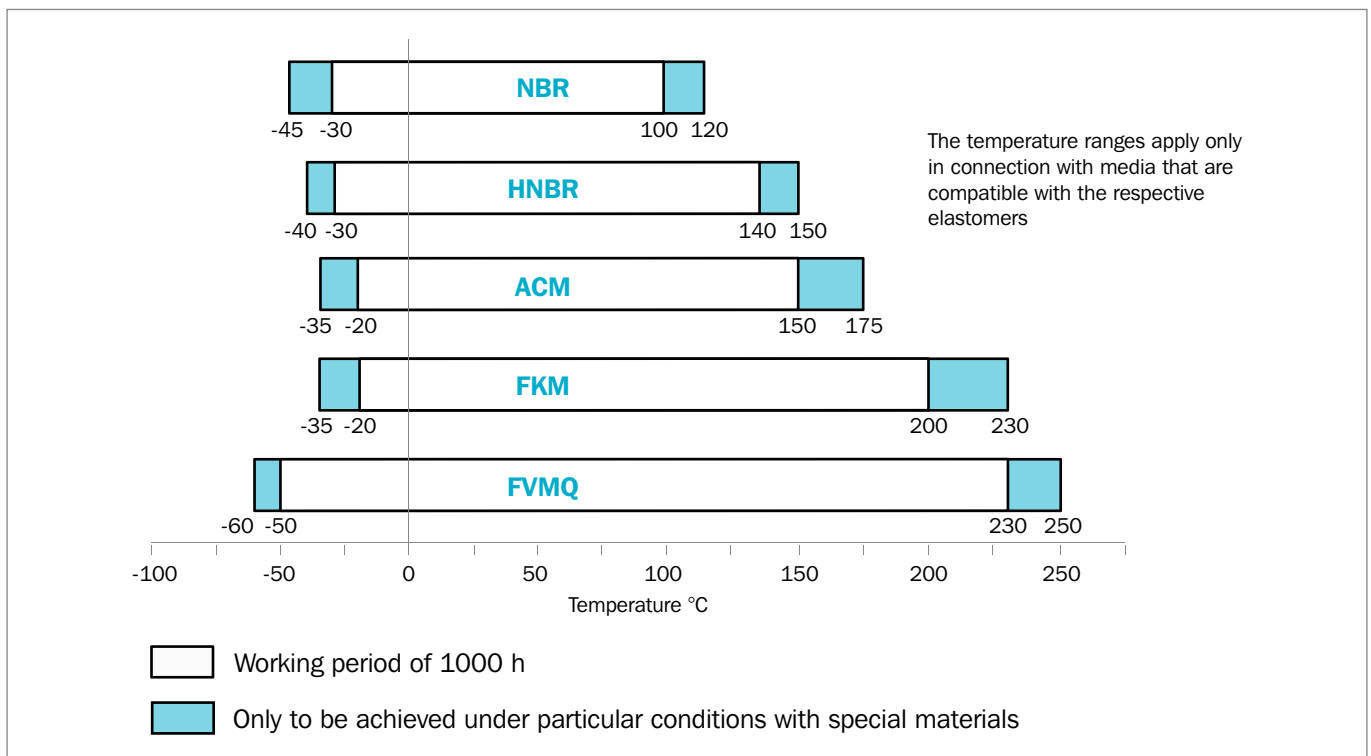

Figure 7: Temperature limits for some common types of rubber

TEMPERATURE

Temperature is the most critical criteria to be considered when selecting a rotary seal.

The temperature limits indicated in the selection tables are maximum operating temperatures of the sealing material in fluids to which the sealing material is compatible (good chemical resistance and controlled swelling/shrinkage).

The above descriptions show that the temperature in the sealing area is influenced by various parameters especially:

- The lubricating capability of the fluid and its ability to dissipate the heat generated under the sealing lip.
- The circumferential velocity
- The pressure applied

The resulting temperature in the sealing area must be considered to select the appropriate material. The initial temperature of the fluid can increase by up to 50% depending on operating parameters. For all applications please refer to the recommendations in the various chapters and contact your local Trelleborg Sealing Solutions marketing company.



MEDIA

The media to be sealed influences heavily the choice of the seal and material type. Mainly liquid media need to be sealed in rotary applications. Pasty media generally restrict the use of rotary seals, especially in terms of circumferential velocity. Gaseous media require specially adapted seal designs.

Liquid media:

Most of the applications relate to lubricating fluids but also hydraulic fluids based on mineral oils acc. DIN 51524 or ISO 6743 or fire resistant hydraulic fluids as well as environmentally friendly hydraulic fluids. In specific applications involving aggressive media with low lubricating capabilities must be sealed. Sealing of other fluids such as water or FDA compliant fluids require in many cases a special sealing solution and will not be covered in detail in this catalog. For specific requirements please contact your local Trelleborg Sealing Solutions marketing company. The media is the first criteria to be considered for the selection of the sealing material type. It will also influence the seal family and the profile.

The evaluation of the compatibility of the seal material with the media to be sealed is based on the analysis of the values of tensile strength, elongation, volume change and hardness change resulting from an immersion test of testing slabs. Please contact your local Trelleborg Sealing Solutions marketing company to select the optimum material for your application.

Mineral oils:

Mainly used in transmissions, elastomer materials have good compatibility with mineral oils within the recommended temperature range. Some mineral oils e.g. hypoid transmission oils contain special additives which produce more demanding operating conditions e.g. temperature range and/or high pressure. For these fields testing is recommended.

Synthetic oils:

For improvement of the viscosity, high temperature and/or service life, new oils with specific additives have been launched as partial or full synthetic oils. Elastomer sealing materials give the same good compatibility to synthetic mineral oils as they do to mineral oils. However, compatibility needs to be checked.

Grease:

Often used for roller and plain bearings, this media requires a specially adapted sealing solution. To reduce the risk of tilting and to allow the sealing lip to open under increasing pressure, the seal is installed in the reverse direction. Another important parameter to be considered is the maximum circumferential velocity. The maximum speed must be reduced to 50% of the permitted speed in oil, due to the poor heat exchange the grease can provide.

Above this limit the change from grease to oil or installation of seal with PTFE-based lip (Turcon®) should be considered.

Poor lubricating media:

For those media an initial lubrication of the seal is required to avoid dry running. In such applications we recommend the radial oil seal with dust lip. The area between the lips will be used as a lubricant reservoir. Two seals in tandem Radial oil seal/Radial oil seal or Radial oil seal/GAMMA seal will provide the same result.

Aggressive media:

Generally aggressive media (e.g. solvents) have poor lubricating properties and therefore we recommend Turcon® Varilip® or PDR seals. Turcon® and other PTFE materials solve the problem of chemical resistance and the metal cage can be produced out of various Stainless Steel materials.



ENVIRONMENTALLY-FRIENDLY HYDRAULIC FLUIDS (BIO OILS)

When machines or process equipment are hydraulically operated, escaping hydraulic oil can pollute surface waters and the ground. One way of minimizing the danger posed by unwanted leakage, is the use of biologically degradable, non-toxic oils. In many countries, there are already statutory regulations and catalogs of requirements for dealing with materials that endanger water. Hydraulic and transmission fluids that protect the environment are already specified in some cases. Figure 8 shows the types of biodegradable fluids.

Environmentally-friendly fluids have application in all systems, which operate in mobile and agricultural machinery and in the water and forestry industries for example. In stationary systems, they are employed in plants where water is at risk, such as locks, water turbines and for foodstuffs and pharmaceutical products.

An important criterion for biologically rapidly-degradable fluids is their compatibility with seals. In Table 5, the resistance of elastomeric materials are given to "bio-oils".

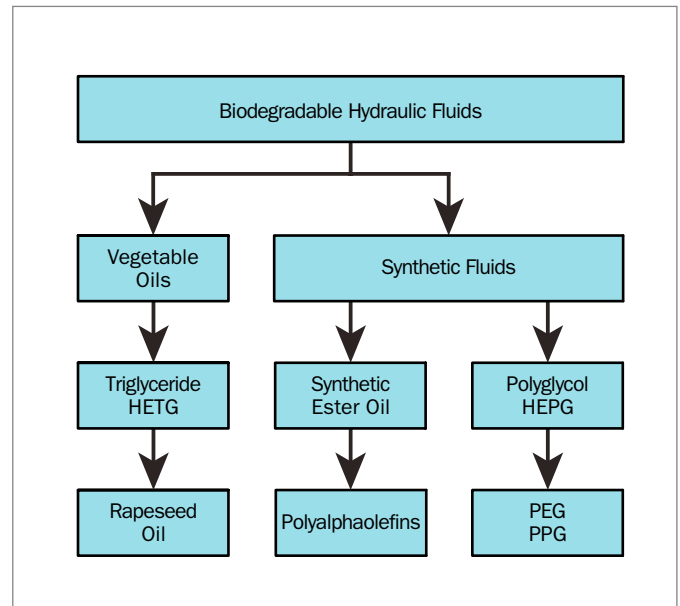

Figure 8: Biodegradable hydraulic fluids

Table 5: Recommendations for the use of standard elastomer materials and accordance with ISO VG 32 to 68 and VDMA Directive 24569

Oil Temperature	< 60 °C	< 80 °C	< 100 °C	< 120 °C
Oil Type / ISO VG	32 - 68	32 - 68	32 - 68	32 - 68
HETG (Rapeseed)	NBR HNBR FKM	NBR HNBR FKM	- - -	- - -
HEES	NBR* HNBR* FKM*	NBR* HNBR* FKM	- - FKM	- - FKM
HEPG (PAG)	NBR* HNBR* FKM*	NBR HNBR FKM**	- HNBR FKM**	- HNBR FKM**
HEPR (PAO)	not yet specified	not yet specified	not yet specified	not yet specified

* For dynamic application, specific test required

** Preferred peroxide cured FKM



OVERPRESSURE

When the sealing element is exposed to pressure it is forced against the shaft and the area of the lip in contact with the shaft increases. The friction, as well as the generated heat, increases. As a result, when the seal is under pressure, the specified values of peripheral speed cannot be maintained but must be reduced in relation to the magnitude of the pressure. At high peripheral speeds even overpressures of 0.01 to 0.02 MPa may cause difficulties. By fitting a separate Back-up Ring, the types (TRA, TRC, TRB) can be used for overpressure above 0.05 MPa. The separate Back-up Ring shape follows the rear profile of the sealing element but without mutual contact when no pressure differential exists (see Figure 9). However, the Back-up Ring requires accurate fitting.

Please ask your local Trelleborg Sealing Solutions marketing company for suitable Back-up Ring drawings. Seal type TRU is formed to support the sealing element (see Figure 9). The type TRP/6CC is designed with a short and sturdy sealing lip, which allows overpressures without using a separate Back-up Ring. When a Back-up Ring is installed or when the types TRU, TRP/6CC are used, overpressures of 0.4 to 0.5 MPa are permissible at moderate peripheral speeds.

At very high pressures, seals with rubber-covered cases should be used to avoid leakage between the periphery of the seal and the housing bore. When the seal is under pressure there is a risk of axial movement in the housing bore (pop-out). This effect can be prevented by locating the seal against a shoulder, with a spacer ring or a circlip.

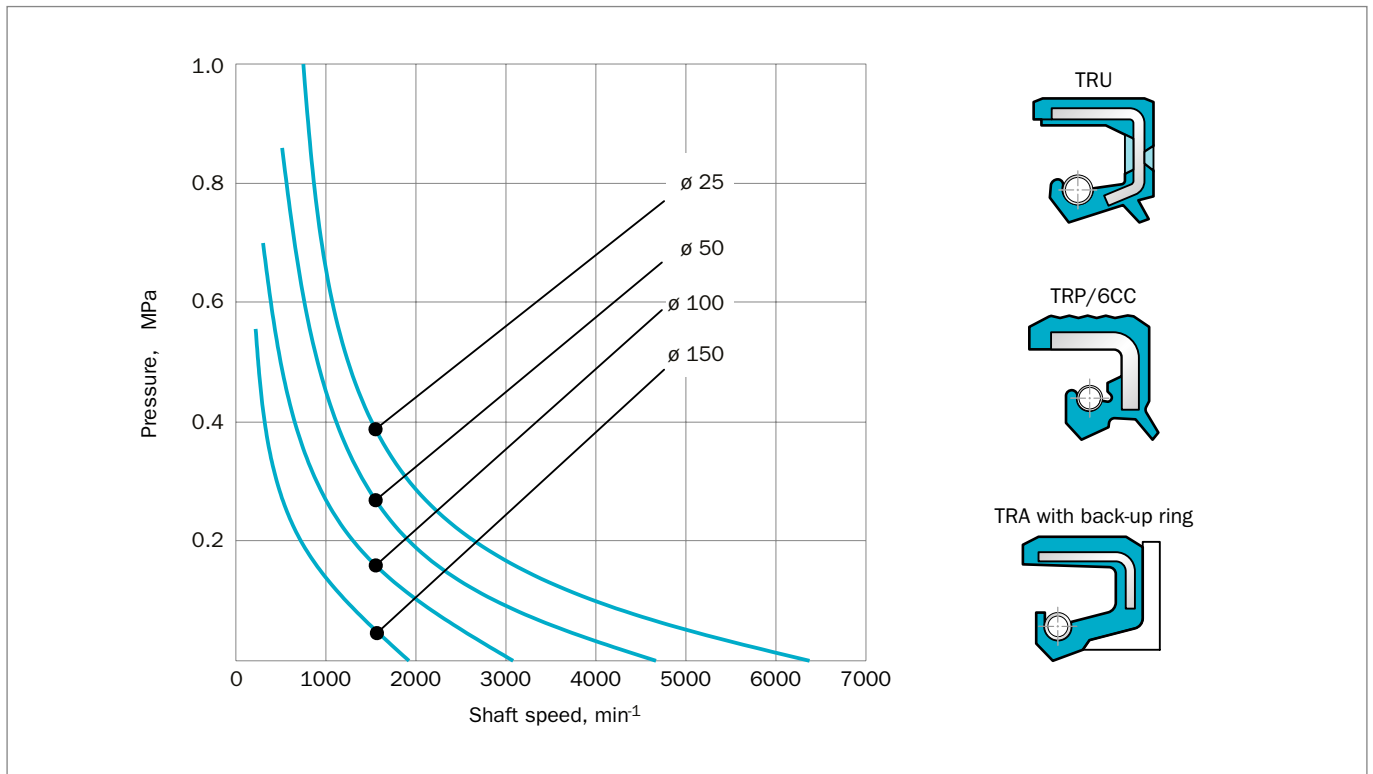

Figure 9: Permissible overpressure for supported lip seals and for pressure seals



PERIPHERAL SPEED AND NUMBER OF REVOLUTIONS

Different designs of the sealing element affect the magnitude of the friction and thus result in varying temperature rises. Various designs of the sealing element allow different maximum peripheral speeds. Figure 10 shows the approximate maximum values for the permissible peripheral speed for sealing elements (without dust lip), i.e. seal type TRC, TRA,

TRB, etc, made with materials NBR or FKM, with no differential pressure, and where adequate lubrication or cooling of the sealing edge by the sealed medium exists. In addition the maximum permissible operating temperatures shown in Table 4 must not be exceeded. The curve shows that higher peripheral speeds are permissible for larger shaft diameters more than for the smaller. This is due to the fact that the cross-sectional area increases in proportion to the square of the diameter, thus increasing the heat dissipation capacity.

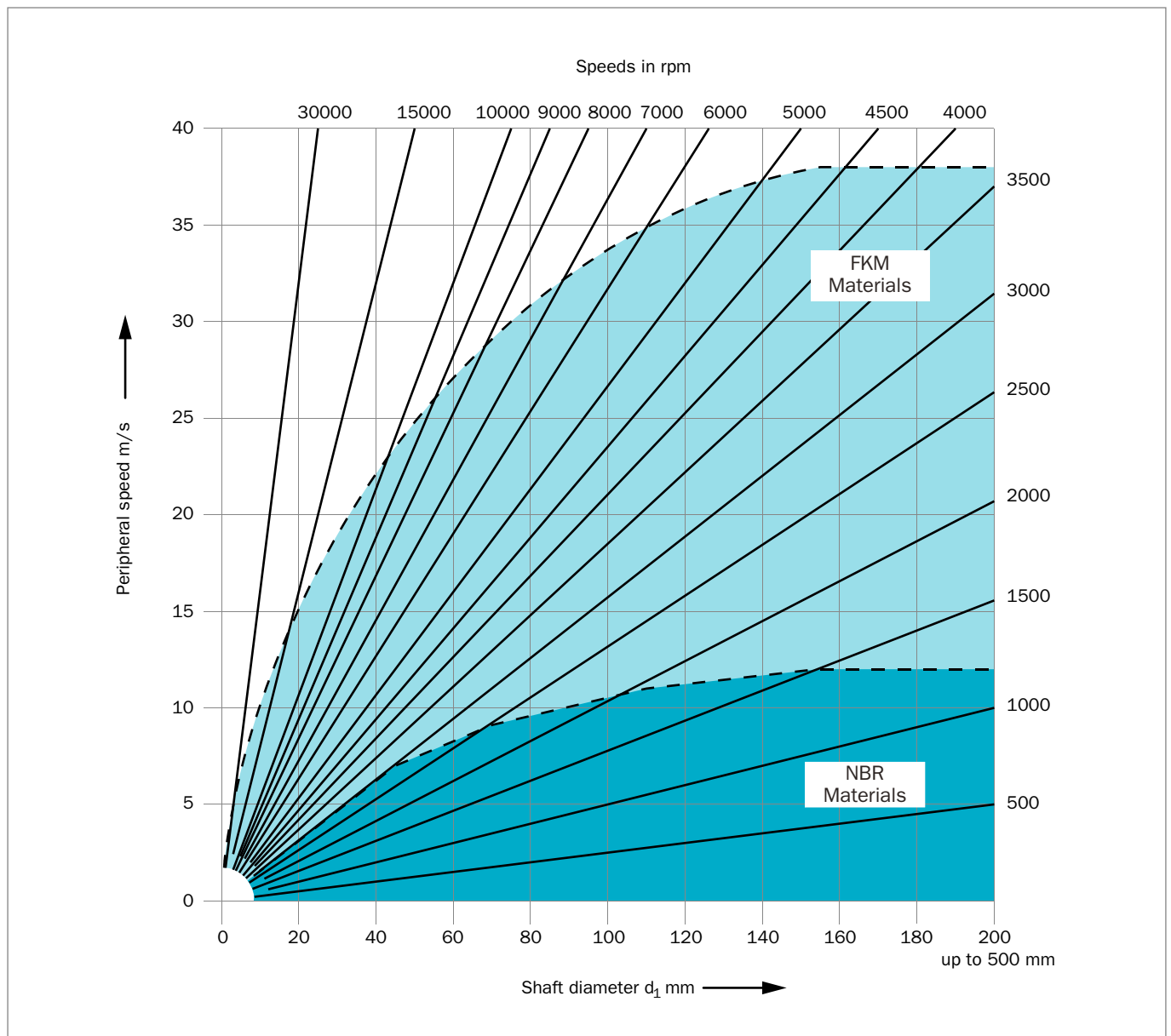

Figure 10: Permissible speeds in pressure-free state to DIN 3761



FRICTIONAL LOSS

The frictional loss is often of significant magnitude, particularly when low powers are transmitted. The frictional loss is affected by the following parameters: seal design and material, spring force, speed, temperature, medium, shaft design, and lubrication. Figure 11 shows the frictional losses in watts caused by a seal without dust lip when fitted in accordance with our technical instructions. In certain cases the frictional loss can be reduced by a special design of the sealing lip, reduction of the spring force or by employing a special grade of rubber. Trelleborg Sealing Solutions engineering teams will be pleased to provide advice on such matters. It should be noted that the frictional loss during the "running in" period is greater than shown in the figure. The normal "running in" period is a few hours.

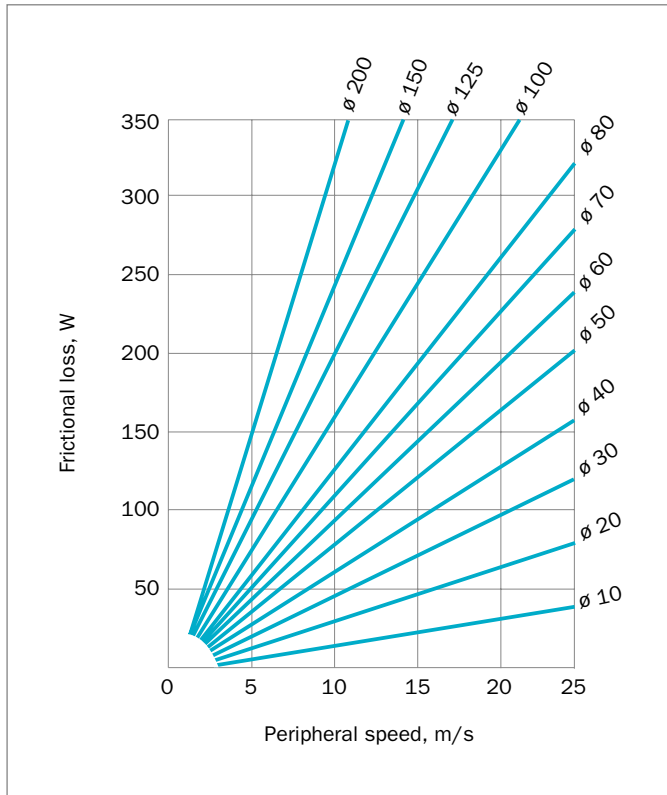

Figure 11: Frictional loss for TRA type seal of Nitrile rubber

LEAKAGE CONTROL

When defining leakage control, one must differentiate between static sealing (sealing of two surfaces without motion relative to one another) and dynamic sealing (relative motion between the two surfaces).

With a moving seal surface, a fluid film separates the sliding surfaces from one another forming a dynamic seal gap. Unlike in static sealing, the leakage path is not fully closed off, so small quantities may escape. Seals in which a dynamic seal gap forms between the seal body and a rotating shaft cannot be tight in the physical sense.

Absolute tightness in the physical sense cannot be achieved with a seal gap alone when sealing moving parts.

For many technical applications, however, it is quite adequate if the "leakage" is reduced to such an extent that there are no negative consequences for the environment or the operation of the assembly. This is called technical tightness.

Technical tightness must be specified by the user or manufacturer of an assembly, i.e. in some circumstances maximum permitted leakage rates must be defined.

For example, leakage classes are defined for oil seals in DIN 3761 Part II (Motor vehicles).

The German standard DIN 3761 classifies the tightness of lip seals into leakage classes 1 to 3. A so called zero-leakage is also defined. Zero-leakage means a function related film of moisture at the sealing edge to a non-drip formation of medium over the back-face of the seal. It is better to accept this "minimum leakage" rather than risking the lip to be damaged due to insufficient lubrication. The permissible leakage in class 1 to 3 is max 1 g to 3 g per seal for a test time of 240 hours.



■ Installation Instructions

The following points must be observed when installing rotary shaft lip seals:

- Before installing, clean the shaft and bore of debris or contamination
- Lubricate the shaft and seal inner diameter with a light coating of grease or oil
- Any sharp-edged transitions on the shaft or bore must either be chamfered or rounded
- When pressing the seal into the bore, take care that it does not deform
- The pressing force must be applied as close as possible to the outer circumference of the seal
- After installation, the seal must be concentric with the bore and at right angles to the shaft
- The end face of the mounting bore is generally used as a depth locator; the seal can also be fixed with a shoulder or a spacer washer.

Figure 12 shows various force fit situations of the rotary shaft lip seal, with suitable installation tools or devices.

IMPORTANT NOTE

The installation of Radial Oil Seals is covered in detail in the Trelleborg Sealing Solutions Installation Instructions app. Search for 'Trelleborg' in the App Store or Google Play to find and download it.

DISMANTLING AND REPLACEMENT

Dismantling of the seal can be accomplished using a screwdriver or similar tool. Take care not to damage the shaft or bore. The seal will be damaged during dismantling and should not be reused.

After repair or maintenance of a machine, a new rotary shaft lip seal must always be installed, even if the old one seems to be still usable. The sealing edge of the new seal should not ride on the same contact area on the shaft as the old seal. This can be achieved by:

- Replacement of shaft sleeves
- Fitting the seal into the bore to a different depth
- Reworking of the shaft and assembling a wear sleeve (see information on Trelleborg Sealing Solutions "Shaft Repair Kit")

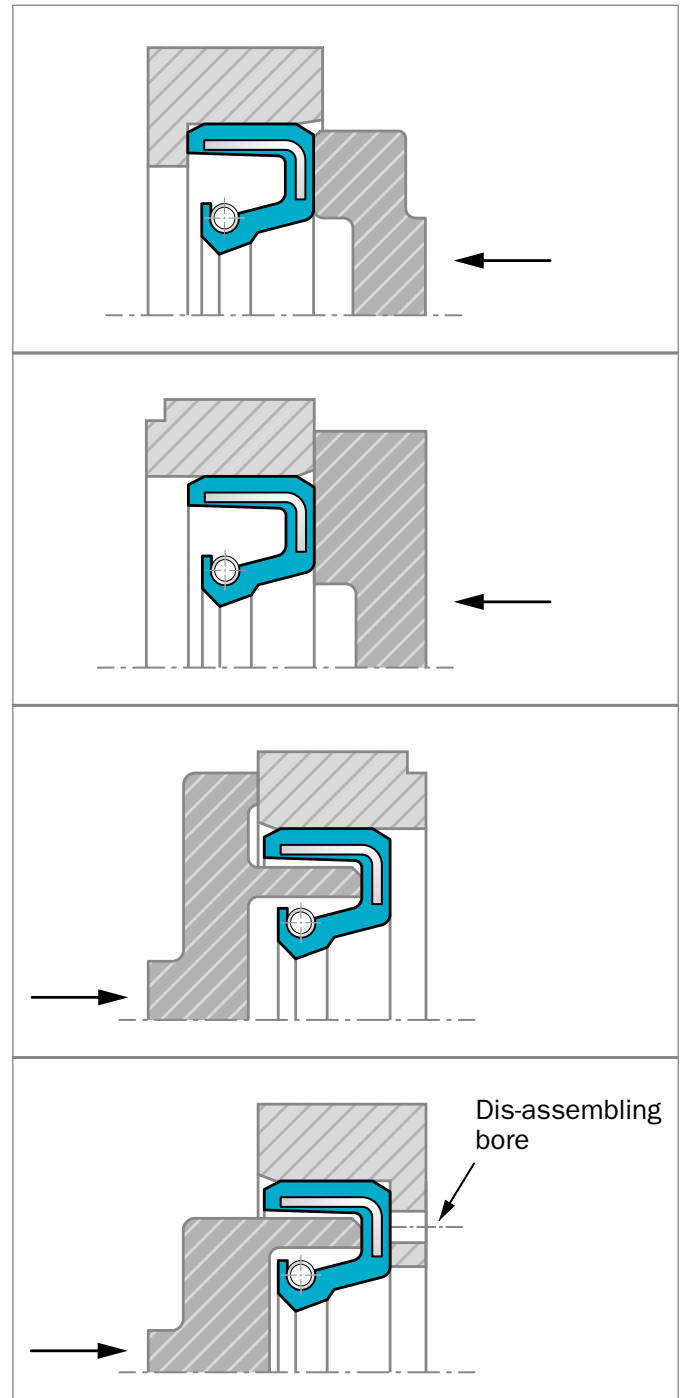

Figure 12: Installation aids for fitting rotary shaft lip seals



■ Standard Radial Oil Seal

Standard elastomeric rotary shaft seals are designed according to DIN 3760 (3761) and ISO 6194/1 recommendations. Types DIN A and DIN AS may have a **wavy or flat outer sheath**.

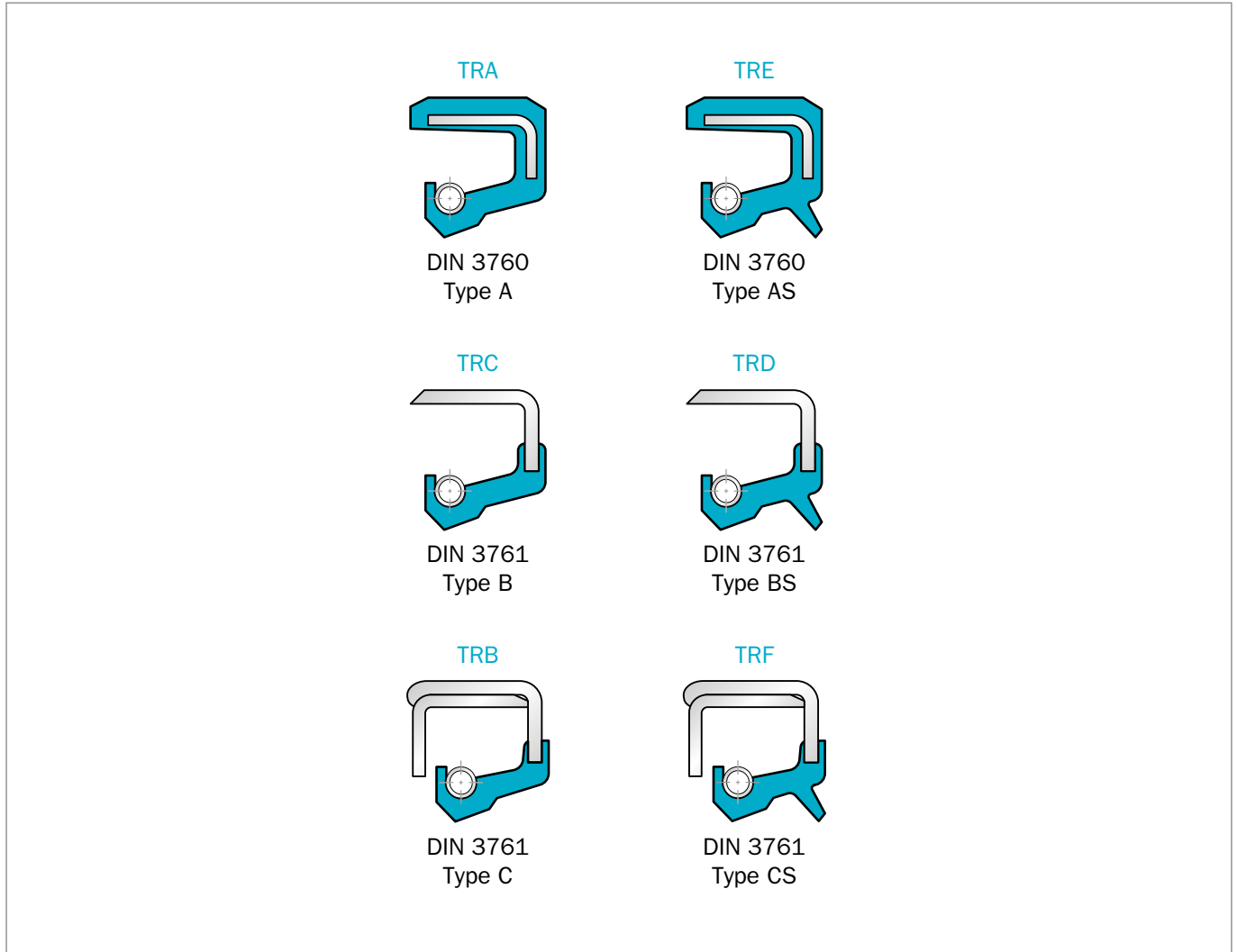

Figure 13: Standard types



■ Type TRA

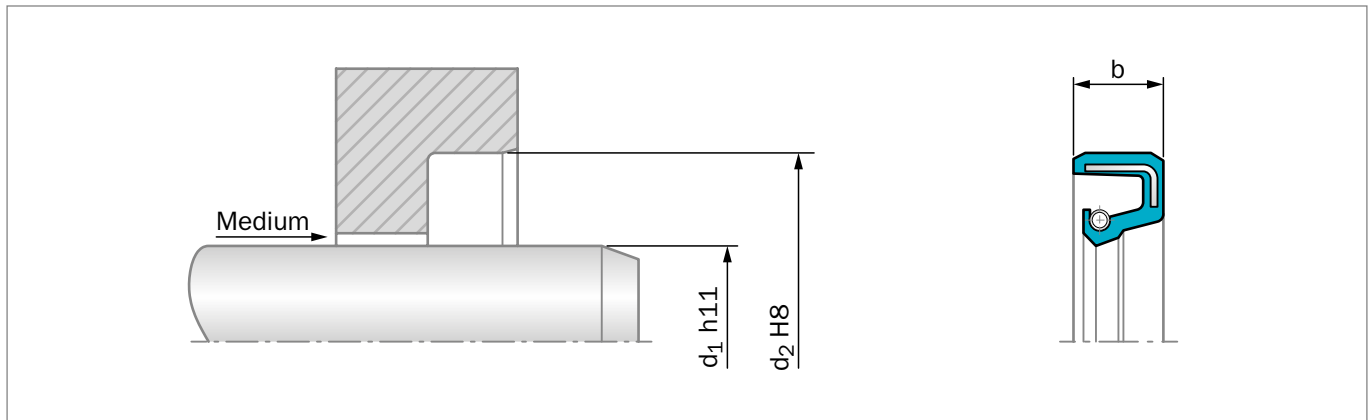

Figure 14: Installation Drawing

GENERAL DESCRIPTION

Trelleborg Sealing Solutions type TRA are seals with completely rubber covered outer diameter. Two different O.D design are available: Flat rubber sheath and wavy.

This type is not recommended for use in heavily polluted environments.

ADVANTAGES

- Good static sealing
- Compensation of different thermal expansion
- Reduced risk of fretting corrosion
- Higher bore surface roughness is allowed
- Installation in split-housings
- Modern lip design provides low radial forces

APPLICATION EXAMPLES

- Transmission systems (e.g. gearboxes)
- Pumps
- Electrical motors
- Machine tools

OPERATING CONDITIONS

Pressure:	Up to 0.05 MPa
Temperature:	-40 °C to +200 °C (depending on material)
Speed:	Up to 10 m/s (depending on material)
Media:	Mineral and synthetic lubricants (CLP, HLP, APGL etc.)

Trelleborg Sealing Solutions has carried out several thousand compatibility tests. Please ask your local Trelleborg Sealing Solutions marketing company for details.

IMPORTANT NOTE

The above data are maximum values and cannot be used at the same time, e. g. the maximum operating speed depends on material type, pressure and temperature.



Table 6: Materials

TSS Compound Reference	Standard Compound	Temperature °C	Standard Metal Insert	Standard Spring
N7MMR	NBR (70 Shore A)	-30 °C - 100 °C	Carbon steel	Carbon steel
4N011/4NV11	NBR (75 Shore A)	-30 °C - 100 °C	Carbon steel	Carbon steel
VCBVR	FKM (70 Shore A)	-20 °C - 200 °C	Carbon steel	Stainless steel
4V012	FKM (75 Shore A)	-20 °C - 200 °C	Carbon steel	Stainless steel

Special grades and other materials (ACM, EACM, EPDM, HNBR, VMQ) on request.
Metal insert and spring can be supplied in different materials on request.

ORDERING EXAMPLE OIL SEAL TSS TYPE

TSS Type:	A
Code:	TRA
Dimensions:	Shaft diameter 25 mm Housing diameter 40 mm Width 7 mm
Material:	NBR
Material Code:	N7MMR

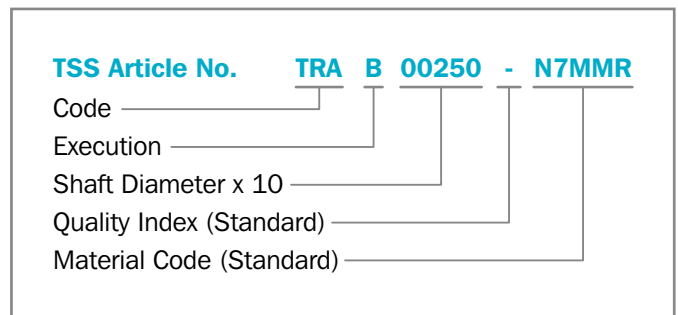

Table 7: Preferred Series / Dimension, TSS Part Numbers

Dimension			TSS Part No.	Material	
d ₁	d ₂	b		NBR	FKM
4	12	6	TRA100040	●	
5	16	7	TRA100050	●	
5	19	5	TRA400050	●	
5.5	22	7	TRA000055	●	
6	12	5.5	TRA400060	●	●
6	15	4	TRA000060	●	●
6	16	5	TRA100060	●	
6	16	7	TRAA00060	●	●
7	17	7	TRA200070	●	
7	22	7	TRAA00070	●	●
8	14	4	TRA700080	●	
8	16	5	TRA100080	●	
8	16	7	TRA200080	●	●
8	18	5	TRA300080	●	●
8	20	8	TRA800080	●	●
8	22	4	TRA500080	●	●
8	22	7	TRAA00080	●	●
9	22	7	TRAA00090	●	
9.5	25.4	8	TRA000095	●	
10	18	4	TRA200100	●	●
10	19	7	TRA400100	●	●
10	20	5	TRAH00100	●	
10	22	6	TRAE00100		●
10	22	7	TRAA00100	●	
10	24	7	TRAB00100	●	●
10	26	7	TRAC00100	●	●
11	19	7	TRA100110	●	
11	26	7	TRAB00110	●	
12	19	5	TRA000120	●	●
12	20	5	TRA200120	●	
12	22	4	TRAF00120	●	●
12	22	7	TRAA00120	●	●
12	24	7	TRAB00120	●	●
12	25	5	TRA600120	●	
12	26	7	TRA800120	●	●
12	28	7	TRAC00120	●	●
12	30	7	TRAD00120	●	●
12	32	7	TRAH00120	●	
12	37	10	TRAK00120	●	
13	25	5	TRA100130	●	
13	26	7	TRA200130	●	
13	30	8	TRA300130	●	
14	22	4	TRA000140	●	●
14	22	7	TRA400140	●	

● In one of the preferred materials
○ In other commercial materials



Dimension			TSS Part No.	Material		Dimension			TSS Part No.	Material	
d ₁	d ₂	b		NBR	FKM	d ₁	d ₂	b		NBR	FKM
14	24	4	TRAE00140			20	30	7	TRAA00200	●	●
14	24	7	TRAA00140	●	●	20	30	8	TRAJ00200		●
14	25	5	TRA100140	●		20	32	7	TRAB00200	●	●
14	28	7	TRAB00140	●	●	20	35	6	TRA600200	●	
14	30	7	TRAC00140	●	●	20	35	7	TRAC00200	●	●
15	24	5	TRAF00150	●	●	20	37	7	TRAM00200	●	
15	24	7	TRA200150	●	●	20	37	8	TRA900200	●	
15	25	5	TRA300150	●		20	40	4	TRAL00200	●	
15	26	6	TRA400150	●		20	40	7	TRAD00200	●	●
15	28	7	TRA600150	●	●	20	42	7	TRAG00200	●	●
15	30	7	TRAB00150	●	●	20	47	7	TRAE00200	●	●
15	32	7	TRAC00150	●	●	20	52	7	TRA400200	●	
15	32	9	TRA800150	●		20	52	10	TRAK00200	●	
15	35	7	TRAD00150	●	●	21	30	6.5	TRA100210	●	
15	37	7	TRAE00150	●		22	32	7	TRAA00220	●	●
15	40	7	TRAN00150		●	22	35	5	TRA200220	●	
15	42	7	TRAG00150	●	●	22	35	7	TRAB00220	●	●
16	24	4	TRA500160	●	●	22	37	7	TRA300220	●	
16	24	5	TRA200160	●		22	40	7	TRAC00220	●	●
16	24	7	TRA300160	●	●	22	52	7	TRAN00220		●
16	26	7	TRA400160	●	●	22.5	53	10	TRA000225		●
16	28	7	TRAA00160	●	●	23	40	10	TRA100230	●	
16	30	7	TRAB00160	●	●	24	35	7	TRAA00240	●	●
16	32	7	TRAC00160	●		24	37	7	TRAB00240	●	
17	25	4	TRA100170	●	●	24	40	7	TRAC00240	●	●
17	26	6	TRA300170	●		24	47	7	TRAD00240	●	●
17	28	5	TRA400170	●	●	25	32	6	TRA000250	●	●
17	28	7	TRAA00170	●	●	25	33	6	TRA300250	●	●
17	30	7	TRAB00170	●	●	25	35	7	TRAA00250	●	●
17	32	7	TRAC00170	●	●	25	37	7	TRA700250	●	●
17	35	7	TRAD00170	●	●	25	38	7	TRA800250	●	●
17	37	7	TRAN00170	●		25	40	5	TRA900250	●	
17	40	7	TRAE00170	●	●	25	40	7	TRAB00250	●	●
17	47	7	TRAG00170	●	●	25	40	10	TRAG00250	●	●
18	24	4	TRA500180		●	25	42	7	TRAC00250	●	●
18	30	7	TRAA00180	●	●	25	43	10	TRAU00250		●
18	35	7	TRAC00180	●	●	25	45	7	TRAI00250	●	●
18	35	10	TRA300180	●		25	47	7	TRAD00250	●	●
19	27	6	TRA600190	●		25	47	8	TRAK00250	●	●
19	32	7	TRA200190	●		25	47	10	TRAL00250	●	●
19	35	7	TRA300190	●		25	52	7	TRAE00250	●	●
19.3	35	6	TRA000193	●		25	52	10	TRA000250	●	
20	28	6	TRA100200	●							
20	30	5	TRA200200	●	●						

- In one of the preferred materials
- In other commercial materials



Dimension			TSS Part No.	Material	
d ₁	d ₂	b		NBR	FKM
25	62	10	TRAR00250	●	
26	34	4	TRA100260	●	
26	37	7	TAA00260	●	
26	47	7	TRAC00260	●	●
27	37	7	TRA300270	●	
27	42	7	TRA000270	●	
27	50	8	TRA100270	●	
28	38	7	TRA000280	●	●
28	40	7	TAA00280	●	●
28	47	7	TRAB00280	●	●
28	47	10	TRA500280	●	●
28	52	7	TRAC00280	●	●
28	80	7	TRA100280	●	
30	40	7	TAA00300	●	●
30	42	5	TRAMGA004	●	
30	42	5.7	TRAV00300	●	
30	42	7	TRAB00300	●	●
30	45	7	TRA400300	●	●
30	45	8	TRA500300	●	
30	47	4	TRA800300	●	
30	47	7	TRAC00300	●	●
30	47	8	TRA900300	●	
30	47	10	TRAF00300	●	●
30	48	8	TRAG00300	●	
30	48	10	TRAMGA008	●	
30	52	7	TRAD00300	●	●
30	55	7	TRAN00300	●	●
30	55	10	TRA000300	●	●
30	62	7	TRAE00300	●	●
30	62	10	TRAR00300	●	●
30	72	8	TRAT00300	●	
30	72	10	TRAU00300	●	●
31	47	7	TRA000310	●	
32	45	7	TAA00320	●	●
32	47	7	TRAB00320	●	●
32	47	10	TRAM00320	●	
32	50	8	TRA400320	●	●
32	52	6	TRAJ00320	●	
32	52	7	TRAC00320	●	●
32	54	8	TRA900320		●
34	52	8	TRA300340	●	●
34	62	10	TRA600340	●	
35	45	7	TRA000350	●	●
35	47	7	TAA00350	●	●

Dimension			TSS Part No.	Material	
d ₁	d ₂	b		NBR	FKM
35	50	7	TRAB00350	●	●
35	52	7	TRAC00350	●	●
35	52	10	TRA500350	●	●
35	55	8	TRA600350	●	●
35	55	10	TRA700350	●	●
35	56	10	TRA900350	●	●
35	60	10	TRAH00350	●	
35	62	7	TRAD00350	●	●
35	62	10	TRAJ00350	●	●
35	68	10	TRAW00350		●
35	72	7	TRAM00350	●	
35	72	10	TRAN00350	●	●
35	72	12	TRA000350	●	
35	80	10	TRAQ00350	●	
35	80	13	TRAS00350	●	
36	47	7	TAA00360	●	●
36	50	7	TRAB00360	●	
36	52	7	TRAC00360		●
37	62	10	TRA200370	●	
38	50	7	TRA000380	●	●
38	52	7	TAA00380	●	●
38	54	6.5	TRA900380	●	●
38	55	7	TRAB00380	●	●
38	62	7	TRAC00380	●	●
38	65	8	TRAK00380	●	
40	50	8	TRA000400	●	●
40	52	7	TAA00400	●	●
40	55	7	TRAB00400	●	●
40	55	10	TRA500400	●	
40	58	10	TRAF00400		●
40	60	10	TRAH00400	●	●
40	62	7	TRAC00400	●	●
40	62	10	TRAI00400	●	●
40	65	10	TRAK00400	●	●
40	68	7	TRAM00400	●	●
40	68	10	TRAN00400		●
40	72	7	TRAD00400	●	●
40	72	10	TRAQ00400	●	●
40	80	7	TRAS00400		●
40	80	10	TRAT00400	●	●
40	85	10	TRAU00400	●	
40	90	8	TRAV00400	●	

- In one of the preferred materials
- In other commercial materials



Dimension			TSS Part No.	Material		Dimension			TSS Part No.	Material	
d ₁	d ₂	b		NBR	FKM	d ₁	d ₂	b		NBR	FKM
40	90	12	TRAW00400	●		50	80	8	TRAD00500	●	
42	55	7	TRA000420	●	●	50	80	10	TRAH00500	●	
42	55	8	TRAA00420	●	●	50	90	10	TRAK00500	●	
42	56	7	TRA100420	●	●	52	68	8	TRAA00520	●	●
42	60	10	TRA200420	●		52	72	8	TRAB00520	●	●
42	62	7	TRA300420	●	●	52	75	12	TRA300520		●
42	62	8	TRAB00420	●	●	52	85	10	TRA700520	●	
42	62	10	TRA400420	●		54	80	10	TRA400540	●	
42	72	7	TRA700420	●		55	68	8	TRA000550	●	●
42	72	8	TRAC00420	●		55	70	8	TRAA00550	●	●
42	72	10	TRA800420	●		55	70	10	TRA100550	●	
44	62	10	TRA100440	●		55	72	8	TRAB00550	●	●
45	55	7	TRA200450	●		55	72	10	TRA200550	●	
45	60	7	TRA400450	●	●	55	75	10	TRA400550	●	●
45	60	8	TRAA00450	●	●	55	80	7	TRAL00550	●	●
45	62	7	TRA600450	●	●	55	80	8	TRAC00550	●	●
45	62	8	TRAB00450	●	●	55	80	10	TRA600550	●	●
45	62	10	TRA800450	●	●	55	85	8	TRAD00550	●	
45	65	8	TRAC00450	●	●	55	85	10	TRA900550	●	●
45	65	10	TRAF00450	●	●	55	90	8	TRAP00550	●	
45	72	8	TRAD00450	●	●	55	90	10	TRAG00550	●	
45	72	10	TRAK00450	●	●	55	100	12	TRAK00550	●	
45	72	12	TRAW00450		●	56	72	8	TRAB00560	●	
45	75	8	TRAM00450	●		58	72	8	TRAA00580	●	
45	75	10	TRAN00450	●	●	58	80	8	TRAB00580	●	●
45	80	8	TRAA00450	●		58	80	10	TRA200580	●	
45	80	10	TRAP00450	●		58.5	100	12	TRA000585	●	
45	85	10	TRAR00450	●		60	70	7	TRA000600	●	
47	62	6	TRA000470	●		60	72	8	TRA100600	●	●
48	62	8	TRAA00480	●	●	60	75	8	TRAA00600	●	●
48	72	8	TRAB00480	●	●	60	78	10	TRA300600		●
48	80	10	TRA600480	●		60	80	7	TRA400600		●
50	62	7	TRA000500	●	●	60	80	8	TRAB00600	●	●
50	65	7	TRA200500		●	60	80	10	TRA500600	●	●
50	65	8	TRAA00500	●	●	60	85	8	TRAC00600	●	●
50	65	10	TRA200500	●	●	60	90	8	TRAD00600	●	●
50	68	8	TRAB00500	●	●	60	90	10	TRAF00600	●	●
50	68	10	TRA300500	●	●	60	95	10	TRAH00600	●	●
50	70	8	TRA500500	●	●	60	100	10	TRAI00600		●
50	70	10	TRA600500	●	●	60	110	10	TRA200600	●	
50	72	6	TRA800500	●		60	110	12	TRAN00600	●	
50	72	7	TRAE00500	●		60	110	13	TRAJ00600	●	●
50	72	8	TRAC00500	●	●						
50	75	10	TRAG00500	●							

- In one of the preferred materials
- In other commercial materials



Dimension			TSS Part No.	Material		Dimension			TSS Part No.	Material	
d ₁	d ₂	b		NBR	FKM	d ₁	d ₂	b		NBR	FKM
62	75	10	TRA000620	●		80	110	12	TRA400800		●
62	80	9	TRA100620	●		80	115	10	TRA600800	●	●
62	80	10	TRA200620	●	●	80	120	12	TRA700800		●
62	85	10	TRAA00620	●	●	80	120	13	TRA900800	●	
62	90	10	TRAB00620	●		85	100	9	TRA300850		●
62	95	10	TRA300620	●		85	105	12	TRAG00850		●
63	85	10	TRAA00630	●	●	85	110	10	TRA100850	●	
65	80	8	TRA000650	●		85	110	12	TRAA00850	●	●
65	85	8	TRA200650		●	85	120	12	TRAB00850	●	●
65	85	10	TRAA00650	●	●	88	110	12	TRA000880	●	
65	90	7	TRAD00650		●	90	110	7.5	TRAE00900		●
65	90	10	TRAB00650	●	●	90	110	8	TRA100900	●	
65	95	10	TRA600650	●		90	110	10	TRA200900	●	●
65	100	10	TRAC00650	●	●	90	110	12	TRAA00900	●	●
65	110	10	TRA900650		●	90	115	12	TRAF00900		●
68	85	10	TRA000680	●		90	120	12	TRAB00900	●	●
68	90	10	TRAA00680	●	●	90	130	13	TRA800900	●	
70	85	7	TRA000700	●		90	140	13	TRA900900	●	●
70	85	8	TRA100700	●	●	95	110	12	TRA500950		●
70	85	10	TRAC00700	●		95	115	13	TRA100950	●	●
70	90	7	TRA800700	●	●	95	120	12	TRAA00950	●	●
70	90	10	TRAA00700	●	●	95	125	12	TRAB00950	●	●
70	95	10	TRA400700	●		95	140	12	TRAC00950	●	●
70	100	6	TRAJ00700	●		95	145	13	TRA700950	●	
70	100	10	TRAB00700	●	●	96	117	10	TRA000960		●
70	110	8	TRA900700	●		100	115	9	TRAG01000	●	●
70	110	12	TRAG00700	●		100	120	6	TRAD01000	●	
72	95	10	TRAA00720	●	●	100	120	7.5	TRAE01000		●
72	100	10	TRAB00720	●		100	120	10	TRA001000	●	
75	90	8	TRA000750	●	●	100	120	12	TRAA01000	●	●
75	90	10	TRA100750	●	●	100	125	12	TRAB01000	●	●
75	95	7	TRAD00750		●	100	130	12	TRAC01000	●	●
75	95	10	TRAA00750	●	●	105	130	12	TRAA01050	●	●
75	100	10	TRAB00750	●	●	105	140	12	TRAB01050	●	
75	110	10	TRA600750		●	105	140	13	TRA601050	●	
75	115	10	TRA500750	●		110	128	12	TRA501100		●
77	95.5	9.5	TRA000770	●		110	130	12	TRAA01100	●	●
78	100	10	TRAA00780	●		110	130	13	TRA201100	●	●
80	95	8	TRA000800		●	110	140	12	TRAB01100	●	●
80	100	7	TRAC00800		●	110	150	13	TRA801100	●	
80	100	10	TRAA00800	●	●	115	135	10	TRA101150	●	●
80	100	13	TRA100800	●	●	115	140	12	TRAA01150	●	●
80	105	13	TRA300800	●							
80	110	10	TRAB00800	●	●						

- In one of the preferred materials
- In other commercial materials



Dimension			TSS Part No.	Material		Dimension			TSS Part No.	Material	
d ₁	d ₂	b		NBR	FKM	d ₁	d ₂	b		NBR	FKM
115	140	13	TRA201150		●	180	200	15	TRA001800	●	
118	150	12	TRA101180	●		180	210	15	TAA01800	●	●
120	140	7.5	TRA901200	●		180	215	15	TRA401800	●	
120	140	13	TRA201200	●	●	180	215	16	TRA101800	●	
120	145	15	TRAF01200	●		184	216	16	TRA001840	●	
120	150	12	TAA01200	●	●	185	210	10	TRA001850		●
120	160	12	TRAB01200	●	●	185	210	13	TRA101850	●	
125	150	12	TAA01250	●	●	190	220	15	TAA01900	●	●
125	160	12	TRAB01250	●	●	190	220	17	TRA601900		●
127	146	11.2	TRA001270	●		190	225	16	TRA101900	●	
130	150	10	TRA001300	●	●	190	230	15	TRA301900		●
130	150	12	TRA801300		●	190	240	15	TRA501900	●	
130	160	12	TAA01300	●	●	191	216	12.7	TRA001910	●	
130	160	13	TRA101300	●	●	195	230	16	TRA001950	●	
130	160	15	TRA301300	●	●	200	230	15	TAA02000	●	●
130	170	12	TRAB01300	●	●	210	240	15	TAA02100	●	●
130	180	15	TRA401300		●	210	250	16	TRA102100	●	
135	170	12	TAA01350	●	●	215	235	10	TRA202150	●	
140	160	10	TRAE01400		●	220	250	15	TAA02200	●	●
140	160	12	TRA201400	●	●	220	270	15	TRA402200	●	
140	160	13	TRA001400	●	●	222	254	16	TRA002220	●	
140	165	12	TRA101400	●	●	230	260	15	TAA02300	●	●
140	170	12	TRA301400	●	●	240	270	15	TAA02400	●	●
140	170	13	TRA401400	●		240	280	15	TRA002400	●	
140	170	15	TAA01400	●	●	248	286	19	TRA002480	●	
140	180	12	TRA801400		●	250	280	15	TAA02500	●	●
145	175	15	TAA01450	●	●	250	290	16	TRA102500	●	
150	170	10	TRA401500	●		260	280	10	TRA202600	●	
150	170	15	TRA101500		●	260	290	15	TRA102600	○	
150	180	12	TRA201500	●	●	260	290	16	TRA002600	●	●
150	180	15	TAA01500	●	●	260	300	20	TAA02600	○	○
155	180	15	TRA101550	●		265	290	16	TRA002650	○	○
160	180	15	TRA001600		●	275	305	12	TRA002750	●	
160	185	10	TRA101600	●		280	310	15	TRA202800		○
160	185	14	TRAF01600	●		280	320	20	TAA02800	●	●
160	190	15	TAA01600	●	●	285.7	323.8	16	TRA002857	●	
160	200	12	TRA401600	●	●	290	330	20	TRA002900	●	
165	190	13	TRA001650	●	●	300	340	18	TRA103000		○
170	190	10	TRA301700	●		300	340	20	TAA03000	●	○
170	200	12	TRA201700	●	●	320	360	20	TAA03200	●	○
170	200	15	TAA01700	●	●	330	360	12	TRA103300	●	
175	200	10	TRA001750		●	340	380	18	TRA003400	●	○
175	205	15	TRAR01750		●						
178	203	11.2	TRA001780	●							

- In one of the preferred materials
- In other commercial materials



Dimension			TSS Part No.	Material	
d ₁	d ₂	b		NBR	FKM
340	380	20	TRAA03400	○	○
350	390	18	TRAA03500	●	●
360	400	20	TRAA03600	○	
370	410	15	TRAA03700	○	○
380	420	20	TRAA03800	○	○
385	425	15	TRAA03850	○	
394	420	16	TRAA03940	○	
400	440	20	TRAA04000	○	○
420	450	15	TRAA04200	●	
420	460	20	TRAA04200	○	○
440	480	20	TRAA04400	○	○
480	520	20	TRAA04800	○	○
500	540	20	TRAA05000	○	○
560	610	20	TRAA05600	○	
670	710	20	TRAA06700	○	
800	840	20	TRAA08000	○	

- In one of the preferred materials
- In other commercial materials



■ Type TRE

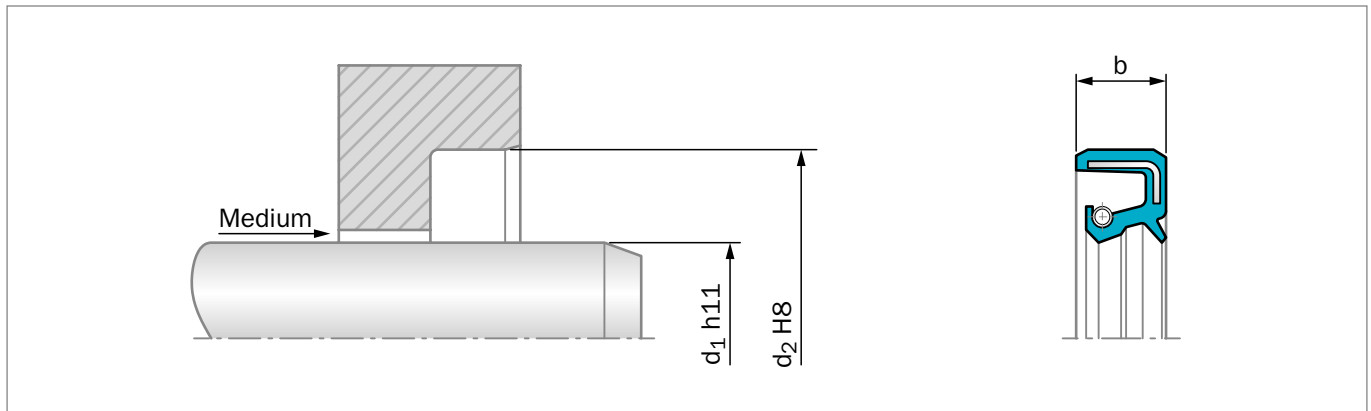

Figure 15: Installation Drawing

GENERAL DESCRIPTION

Trelleborg Sealing Solutions Type TRE are seals with completely rubber covered outer diameters. Two different O.D. design are available: Flat rubber sheath and wavy. The additional dust lip protects the main sealing lip against dust and other fine solid contaminants and therefore this type is recommended for use in polluted environments. To achieve a long lifetime, a suitable lubricant between the two sealing lips should be applied.

ADVANTAGES

- Good static sealing
- Compensation of different thermal expansion
- Reduced risk of fretting corrosion
- Effective protection against air side contaminants
- Higher bore surface roughness is allowed
- Installation in split-housings
- Modern lip design provides low radial forces

APPLICATION EXAMPLES

- Transmission systems (e.g. gearboxes)
- Pumps
- Electrical motors
- Machine tools

OPERATING CONDITIONS

Pressure:	Up to 0.05 MPa
Temperature:	-40 °C to +200 °C (depending on material)
Speed:	Up to 10 m/s (depending on material)
Media:	Mineral and synthetic lubricants (CLP, HLP, APGL etc.)

Trelleborg Sealing Solutions has carried out several thousand compatibility tests. Please ask your local Trelleborg Sealing Solutions marketing company for details.

IMPORTANT NOTE

The above data are maximum values and cannot be used at the same time, e. g. the maximum operating speed depends on material type, pressure and temperature.



Table 8: Materials

TSS Compound Reference	Standard Compound	Temperature °C	Standard Metal Insert	Standard Spring
N7MMR	NBR (70 Shore A)	-30 °C - 100 °C	Carbon steel	Carbon steel
4N011/4NV11	NBR (75 Shore A)	-30 °C - 100 °C	Carbon steel	Carbon steel
VCBVR	FKM (70 Shore A)	-20 °C - 200 °C	Carbon steel	Stainless steel
4V012	FKM (75 Shore A)	-20 °C - 200 °C	Carbon steel	Stainless steel

Special grades and other materials (ACM, EACM, EPDM, HNBR, VMQ) on request.
Metal insert, and spring as well, can be supplied in different materials on request.

ORDERING EXAMPLE OIL SEAL TSS TYPE

TSS Type:	E
Code:	TRE
Dimensions:	Shaft diameter 15 mm Housing diameter 30 mm Width 7 mm
Material:	NBR
Material Code:	N7MMR

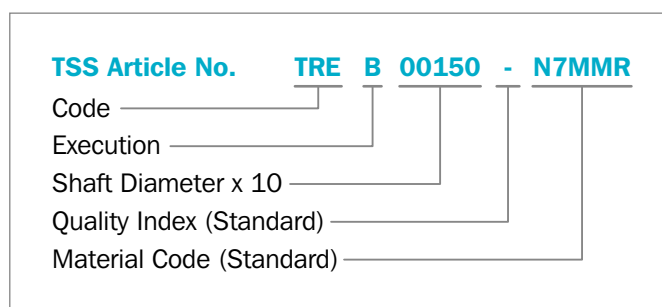

Table 9: Preferred Series / Dimension, TSS Part Numbers

Dimension			TSS Part No.	Material	
d ₁	d ₂	b		NBR	FKM
6	16	5	TRE000060	●	
6	16	7	TREA00060	●	
8	16	5	TRE500080		
8	16	7	TRE000080	●	
8	18	5	TRE300080		●
8	22	7	TRE100080	●	
10	18	6	TRE100100	●	
10	19	7	TRE200100	●	
10	20	5	TRE300100	●	
10	22	7	TREA00100	●	
10	26	7	TREC00100	●	
11	17	4	TRE000110	●	
12	19	5	TRE000120	●	●
12	20	5	TRE400120	●	
12	22	7	TREA00120	●	●
12	25	7	TREE00120	●	
12	28	7	TREC00120	●	●
12	32	7	TRE300120	●	●
12	37	10	TRE900120	●	
14	21	4	TRE300140	●	
14	22	4	TRE400140		●
14	23	5	TRE100140		●
14	24	7	TREA00140	●	●

Dimension			TSS Part No.	Material	
d ₁	d ₂	b		NBR	FKM
14	35	7	TRED00140		●
15	24	5	TREH00150	●	
15	24	7	TRE000150	●	
15	25	5	TRE600150		●
15	26	7	TREA00150	●	
15	28	7	TRE100150	●	
15	30	7	TREB00150	●	●
15	30	10	TRE700150		●
15	32	7	TREC00150	●	●
15	35	7	TRED00150	●	
15	42	7	TRE300150	●	
16	22	7	TRE500160	●	
16	28	7	TREA00160	●	●
16	29	4	TRE400160	●	
16	30	7	TREB00160	●	●
16	32	7	TREC00160		●
17	28	6	TRE000170	●	
17	28	7	TREA00170	●	●
17	30	7	TREB00170	●	●
17	35	7	TRED00170	●	
17	40	7	TREE00170	●	●

● In one of the preferred materials
○ In other commercial materials



Dimension			TSS Part No.	Material		Dimension			TSS Part No.	Material	
d ₁	d ₂	b		NBR	FKM	d ₁	d ₂	b		NBR	FKM
17	42	7	TRE200170	●		25	44	7	TREQ00250		●
18	28	7	TRE000180	●		25	47	7	TRED00250	●	●
18	30	6	TRE400180	●		25	47	10	TRE700250	●	
18	30	7	TREA00180	●		25	52	7	TREE00250	●	●
18	32	7	TREB00180	●	●	25	52	10	TRE900250	●	
18	47	6	TRE800180	●		25	62	7	TREG00250	●	●
18	47	10	TRE900180	●		26	37	7	TREA00260	●	
20	30	5	TRES00200			26	52	8	TRE100260	●	
20	30	7	TREA00200	●	●	27	37	7	TRE200270	●	
20	32	7	TREB00200	●		28	38	7	TRE700280		●
20	34	7	TRE100200	●		28	40	7	TREA00280	●	●
20	35	7	TREC00200	●	●	28	45	7	TREE00280		●
20	36	7	TRE200200	●		28	47	7	TREB00280	●	
20	40	7	TRED00200	●		28	47	10	TRE400280	●	
20	42	7	TRE300200	●	●	29	52	7	TRE100290	●	
20	47	7	TREE00200	●	●	30	40	7	TREA00300	●	●
20	52	7	TRE600200	●		30	42	6	TRE000300	●	
20	52	8	TREG00200		●	30	42	7	TREB00300	●	●
20	55	7	TREF00200	●	●	30	42	8	TRE100300	●	
20	62	7	TRER00200		●	30	43	8	TRER00300	●	
21.4	29.5	4	TRE000214	●		30	45	8	TRE200300	●	
22	28	4	TRE700220	●	●	30	47	7	TREC00300	●	●
22	32	7	TREA00220	●	●	30	47	8	TREK00300	●	●
22	35	7	TREB00220	●	●	30	50	7	TRE300300	●	●
22	37	7	TRE000220		●	30	50	8	TREP00300	●	
22	40	7	TREC00220	●	●	30	50	10	TRE600300	●	
22	52	7	TRE600220	●		30	52	7	TRED00300	●	●
22	52	10	TREG00220		●	30	52	10	TRE700300	●	
22	62	6	TRE800220	●		30	55	7	TRE800300	●	●
22	62	10	TREE00220	●		30	55	10	TRE900300	●	
23	32	5	TRE100230	●	●	30	62	7	TREE00300	●	●
23	34	5	TRE200230	●	●	30	62	10	TREF00300	●	●
24	32	7	TRE000240	●		30	72	10	TREG00300	●	●
24	35	7	TREA00240	●		30	80	10	TREI00300	●	
24	40	7	TREC00240	●	●	32	42	5	TRE300320	●	
24	47	7	TRED00240	●	●	32	42	7	TRE800320		
25	32	6	TRER00250		●	32	45	7	TREA00320	●	
25	35	6	TRE000250	●		32	47	7	TREB00320	●	●
25	35	7	TREA00250	●	●	32	50	10	TRE100320	●	
25	38	8	TREK00250	●		32	52	7	TREC00320	●	●
25	40	5	TREF00250	●		32	80	7	TREM00320	●	
25	40	7	TREB00250	●		34	65	8	TRE400340		●
25	40	8	TRE100250	●							
25	42	7	TREC00250	●							

- In one of the preferred materials
- In other commercial materials



Dimension			TSS Part No.	Material	
d ₁	d ₂	b		NBR	FKM
35	42	4	TREX00350		●
35	45	7	TRE000350	●	
35	47	7	TREA00350	●	●
35	47	8	TRES00350	●	
35	50	7	TREB00350	●	
35	50	8	TREW00350	●	
35	50	10	TREL00350	●	
35	52	6	TRE100350	●	
35	52	7	TREC00350	●	●
35	52	10	TRE200350	●	
35	55	8	TREK00350	●	
35	56	10	TRE300350	●	
35	58	10	TREG00350	●	●
35	62	7	TRED00350	●	
35	62	8	TREU00350	●	
35	62	10	TRE400350	●	●
35	62	12	TRE500350		●
35	65	10	TRE600350	●	
35	65	12	TREP00350	●	
35	72	7	TREH00350		●
35	72	8	TREJ00350	●	
35	72	10	TRE700350	●	●
35	72	12	TRE800350	●	●
35	80	12	TRE000350	●	
36	52	6.3	TRE200360	●	
36	54	7	TRE100360	●	
37	62	7	TRE100370		●
37.5	75	8	TRE000375	●	
38	52	7	TREA00380	●	
38	55	8	TRE100380		●
38	62	7	TREC00380	●	●
38	62	10	TRE500380	●	
38	69	9.5	TREH00380	●	
38	72	10	TRED00380	●	●
38	80	8	TREG00380		●
40	52	5	TRE000400	●	
40	52	7	TREA00400	●	●
40	55	6	TRE000400	●	
40	55	7	TREB00400	●	●
40	55	8	TRE100400	●	●
40	56	8	TREG00400	●	●
40	60	10	TRE400400	●	●
40	62	6	TREMGE003	●	
40	62	7	TREC00400	●	●

Dimension			TSS Part No.	Material	
d ₁	d ₂	b		NBR	FKM
40	62	10	TRE600400	●	●
40	62	12	TREJ00400	●	
40	65	8	TREM00400	●	
40	68	7	TRE700400	●	
40	68	8	TREY00400		●
40	68	10	TREW00400		●
40	72	7	TRED00400	●	●
40	72	10	TRE800400	●	
40	80	7	TRE900400	●	
40	80	10	TREF00400	●	●
40	90	12	TREH00400	●	●
40	90	13.5	TRE000400	●	
42	62	7	TRE300420	●	
42	62	10	TRE800420		●
42	72	8	TREC00420	●	
42	72	10	TRE600420	●	●
44	65	10	TRE000440		●
45	52	4	TREX00450	●	
45	55	7	TREL00450	●	
45	60	7	TRE000450	●	●
45	60	8	TREA00450	●	
45	62	7	TRE100450	●	●
45	62	8	TREB00450	●	●
45	65	7	TREU00450		●
45	65	8	TREC00450	●	●
45	65	10	TRE300450	●	●
45	68	10	TRE500450	●	
45	70	10	TRE000450	●	
45	72	8	TRED00450	●	●
45	75	7	TRE800450	●	●
45	75	8	TREI00450	●	●
45	75	10	TRE900450	●	●
45	80	10	TREF00450	●	
45	85	8	TRET00450	●	
45	85	10	TREG00450	●	●
45	90	10	TREH00450	●	●
45	100	8	TREW00450	●	
47	90	10	TRE000470	●	
48	62	8	TREA00480	●	●
48	65	10	TRE000480	●	
48	68	10	TRE100480	●	
48	70	10	TRE500480		●

- In one of the preferred materials
- In other commercial materials



Dimension			TSS Part No.	Material		Dimension			TSS Part No.	Material	
d ₁	d ₂	b		NBR	FKM	d ₁	d ₂	b		NBR	FKM
48	72	7	TRE200480	●		60	75	6	TREJ00600	●	
48	72	8	TREB00480	●		60	75	8	TREA00600	●	●
48	72	10	TRE700480		●	60	80	6	TREE00600	●	
48	72	12	TRE300480	●		60	80	8	TREB00600	●	●
48	90	13	TRE600480	●		60	80	10	TRE100600	●	●
50	62	7	TRE200500	●		60	82	9	TRE200600	●	
50	65	8	TREA00500	●	●	60	85	8	TREC00600	●	●
50	68	7	TREK00500	●		60	85	10	TRE300600	●	
50	68	8	TREB00500	●	●	60	90	8	TRED00600	●	●
50	68	9	TREG00500			60	90	8	TREN00600	●	
50	70	10	TRE100500	●	●	60	90	10	TRE400600		●
50	72	7	TREF00500	●		60	95	8	TREK00600		●
50	72	8	TREC00500	●	●	60	95	10	TRE500600	●	
50	72	10	TRE300500	●	●	60	100	10	TREM00600	●	●
50	75	10	TRE500500	●	●	60	110	8	TRE900600	●	
50	80	8	TRED00500	●	●	60	110	10	TRE700600	●	●
50	80	10	TRE600500	●		60	110	13	TREG00600	●	
50	90	8	TRE800500	●	●	62	110	10	TRE100620	●	
50	90	10	TRE900500	●	●	62	120	12	TRE200620	●	
50	100	10	TREM00500		●	64	85	10	TRE100640		●
50	110	10	TREH00500		●	65	80	8	TRE00650	●	●
52	62	8	TRE600520		●	65	85	10	TREA00650	●	●
52	68	8	TREA00520	●	●	65	85	12	TREG00650	●	
52	72	8	TREB00520	●	●	65	85	13	TRE300650		●
52	85	10	TRE400520	●		65	90	10	TREB00650	●	●
52	100	10	TRE500520	●		65	100	10	TREC00650	●	●
55	68	8	TRE000550	●		65	110	10	TRED00650	●	●
55	70	8	TREA00550	●	●	65	120	13	TREF00650	●	
55	72	7	TREE00550	●		68	90	10	TREA00680	●	
55	72	8	TREB00550	●	●	68	92	10	TRE400680	●	
55	72	10	TRE200550	●	●	68	110	13	TRE100680	●	
55	75	8	TRE300550	●	●	70	85	8	TRE000700	●	
55	75	12	TRE500550	●		70	90	7	TRE800700	●	
55	80	8	TREC00550	●	●	70	90	10	TREA00700	●	●
55	80	10	TRE600550	●	●	70	100	10	TREB00700	●	●
55	85	10	TRE700550	●		70	110	8	TRE700700	●	
55	90	5	TRE100550	●		70	110	13	TRE400700	●	
55	90	8	TREG00550	●	●	70	125	12	TRE600700	●	
55	90	10	TRE800550	●		70	160	12	TREG00700	●	
55	100	8	TRED00550	●	●	72	86	7	TRE100720	●	
55	100	10	TRE900550	●		72	95	10	TREA00720	●	
57	80	12	TRE000570		●	72	95	12	TRE000720	●	
58	80	10	TRE000580	●	●						
60	72	8	TRELO0600	●	●						

- In one of the preferred materials
- In other commercial materials



Dimension			TSS Part No.	Material	
d ₁	d ₂	b		NBR	FKM
72	100	10	TREB00720		●
72	110	13	TRE400720	●	
72	140	12	TRE300720	●	
75	90	8	TRE400750	●	
75	90	10	TREC00750		●
75	95	9	TRE600750	●	
75	95	10	TREA00750	●	●
75	100	10	TREB00750	●	●
75	110	10	TRED00750		●
75	115	10	TRE800750	●	
75	120	12	TRE300750	●	
78	100	10	TREA00780	●	
79	120	13	TRE000790	●	
80	95	8	TREC00800	●	
80	100	7	TRE000800	●	●
80	100	10	TREA00800	●	●
80	100	13	TRE100800	●	●
80	105	13	TRE200800	●	●
80	110	10	TREB00800	●	
80	115	10	TRE300800	●	●
80	120	13	TRE400800	●	
80	140	13	TRE900800	●	
80	140	15	TRE600800	●	
85	105	12	TRE800850		●
85	110	12	TREA00850	●	●
85	110	13	TRE200850		●
85	120	12	TREB00850	●	●
85	130	10	TRE400850	●	
85	130	12	TRE700850	●	●
85	132	12	TRED00850		●
85	140	12	TREG00850		●
85	150	12	TRE600850	●	
90	110	7.5	TRE800900	●	●
90	110	8	TRE600900	●	●
90	110	12	TREA00900	●	●
90	120	12	TREB00900	●	●
90	120	13	TRE200900	●	●
90	125	13	TRE700900	●	●
90	140	12	TRE400900	●	
95	110	12	TREC00950		●
95	115	12	TRE000950	●	
95	120	12	TREA00950	●	●
95	120	13	TRE200950	●	●
95	125	12	TREB00950	●	●

Dimension			TSS Part No.	Material	
d ₁	d ₂	b		NBR	FKM
95	130	13	TRE300950	●	
95	140	12	TRED00950		●
97	112	8	TRE000970	●	
100	120	10	TRE001000	●	
100	120	12	TREA01000	●	●
100	125	12	TREB01000	●	
100	125	13	TRE101000	●	
100	130	12	TREC01000	●	
100	130	13	TRE201000	●	●
100	140	12	TRE701000	●	
100	150	12	TRE501000	●	
100	160	14	TRE301000		●
100	180	12	TRE401000	●	
105	120	7	TRE001050	●	
105	125	13	TRE101050	●	
105	130	12	TREA01050	●	●
105	140	12	TREB01050	●	●
110	130	12	TREA01100	●	
110	140	12	TREB01100	●	●
110	140	13	TRE401100	●	●
110	150	13	TRE601100	●	
110	165	12	TRE001100		●
110	170	14	TRE301100	●	
110	215	15	TRE701100	●	
115	130	12	TRE101150	●	
115	140	12	TREA01150	●	●
115	150	12	TREB01150	●	●
115	160	12	TRE301150		●
117	200	15	TRE001170		●
118	150	12	TRE001180	●	
120	140	7.5	TRE701200	●	
120	140	13	TRE001200	●	●
120	142	12	TRE501200	●	
120	150	12	TREA01200	●	●
120	150	15	TRE201200	●	●
120	160	12	TREB01200	●	
120	160	15	TRE601200	●	
120	180	15	TRE401200	●	●
125	150	12	TREA01250	●	●
125	155	14	TRE301250	●	
127	158.75	17.46	TRE001270		●
130	150	10	TREF01300		●

- In one of the preferred materials
- In other commercial materials



Dimension			TSS Part No.	Material		Dimension			TSS Part No.	Material	
d ₁	d ₂	b		NBR	FKM	d ₁	d ₂	b		NBR	FKM
130	150	12	TRE301300		●	185	210	13	TRE101850	●	
130	160	7.5	TRE401300	●		190	215	15	TRE401900	●	
130	160	12	TREA01300	●	●	190	220	12	TRE001900	●	
130	160	15	TRE001300	●	●	190	220	15	TREA01900	●	●
130	170	12	TREB01300	●		195	215	15	TRE201950	●	
132	152	6	TRE101320	●		200	225	8.5	TRE202000	●	
135	160	15	TRE001350	●		200	230	15	TREA02000	●	●
135	170	10	TRE301350	●		210	240	15	TREA02100	●	
135	170	12	TREA01350	●	●	220	250	15	TREA02200	●	●
140	160	10	TRE801400	●		230	260	15	TREA02300	●	
140	160	12	TRE601400		●	240	270	15	TREA02400	●	○
140	160	13	TRE001400	●		240	320	20	TRE002400		●
140	170	12	TRE201400	●		250	280	11	TRE102500	●	
140	170	13	TRE901400		●	250	280	15	TREA02500	●	●
140	170	15	TREA01400	●		260	280	16	TRE002600	●	●
140	180	12	TRE501400		●	260	290	16	TRE102600	●	●
140	210	15	TRE301400	●		260	300	20	TREA02600	●	●
144	160	12	TRE001440	●		265	290	15	TRE002650	●	
145	175	15	TREA01450	●	●	280	320	20	TREA02800	●	●
150	170	10	TRE101500		●	300	340	16	TRE103000	●	○
150	170	12	TRE301500		●	300	340	20	TREA03000	○	○
150	180	15	TREA01500	●	●	320	360	20	TREA03200	○	○
155	174	12	TRE401550		●	350	380	16	TRE003500	●	●
155	180	15	TRE001550	●	●	360	400	20	TREA03600	○	○
155	190	13	TRE301550		●	380	420	20	TREA03800	○	
160	185	15	TRE601600	●	●	394	420	16	TRE003940	○	
160	190	15	TREA01600	●	●	420	450	12	TRE104200	●	
160	200	15	TRE001600	●		420	460	20	TREA04200	○	
160	210	15	TRE401600	●		440	480	20	TREA04800	○	
160	240	14	TRE701600	●		920	970	20	TRE009200		
165	190	8	TRE101650	●							
165	190	13	TRE201650	●	●						
166	179	8	TRE001660		●						
170	185	9.5	TRE301700		●						
170	195	7.5	TRE401700	●							
170	200	15	TREA01700	●	●						
174	190	5	TRE001740	●							
175	205	15	TRE001750	●							
178	205	15	TREA01780	●							
180	200	13	TRE101800	●							
180	210	15	TREA01800	●	●						
180	215	15	TRE201800	●							
180	215	16	TRE501800		●						
180	220	16	TRE401800	●							

- In one of the preferred materials
- In other commercial materials



■ Type TRC

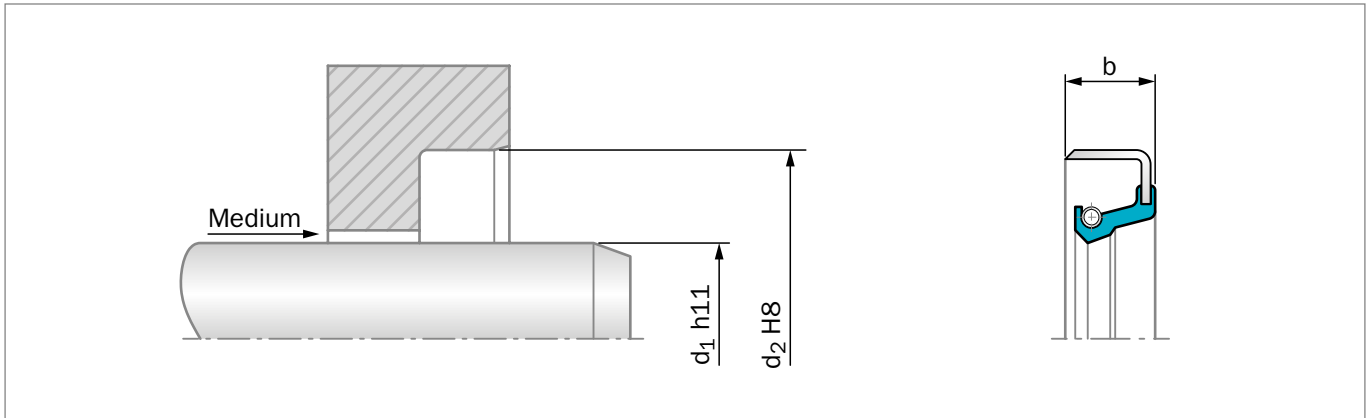

Figure 16: Installation Drawing

GENERAL DESCRIPTION

Trelleborg Sealing Solutions Type TRC are metal cased radial lip seals. This type is not recommended for use in heavily polluted environments. As the static sealing between housing and metallic shell is limited, low viscosity media can "creep". Better performance can be achieved with Epoxy-based resin O.D. coating. This special treatment is on request.

ADVANTAGES

- Good radial stiffness, especially for large diameters
- Good fitting stability avoiding pop-out of the seal
- Modern lip design provides low radial forces
- Cost effective
- Suitable for use in combination with axial seal (V-Ring and GAMMA-seal)

APPLICATION EXAMPLES

- Transmission systems (e.g. gearboxes)
- Pumps
- Electrical motors
- Machine tools
- Heavy engineering applications

OPERATING CONDITIONS

Pressure:	Up to 0.05 MPa
Temperature:	-40 °C to +200 °C (depending on material)
Speed:	Up to 10 m/s (depending on material)
Media:	Mineral and synthetic lubricants (CLP, HLP, APGL etc.)

Trelleborg Sealing Solutions has carried out several thousand compatibility tests. Please ask your local Trelleborg Sealing Solutions marketing company for details.

IMPORTANT NOTE

The above data are maximum values and cannot be used at the same time, e. g. the maximum operating speed depends on material type, pressure and temperature.

**Table 10: Materials**

TSS Compound Reference	Standard Compound	Temperature °C	Standard Metal Insert	Standard Spring
N7MMR	NBR (70 Shore A)	-30 °C - 100 °C	Carbon steel	Carbon steel
4N011/4NV11	NBR (75 Shore A)	-30 °C - 100 °C	Carbon steel	Carbon steel
VCBVR	FKM (70 Shore A)	-20 °C - 200 °C	Carbon steel	Stainless steel
4V012	FKM (75 Shore A)	-20 °C - 200 °C	Carbon steel	Stainless steel

Special grades and other materials (ACM, EACM, EPDM, HNBR, VMQ) on request.
Metal insert, and spring can be supplied in different materials on request.

ORDERING EXAMPLE OIL SEAL TSS TYPE

TSS Type:	C
Code:	TRC
Dimensions:	Shaft diameter 20 mm Housing diameter 35 mm Width 7 mm
Material:	NBR
Material Code:	N7MMR

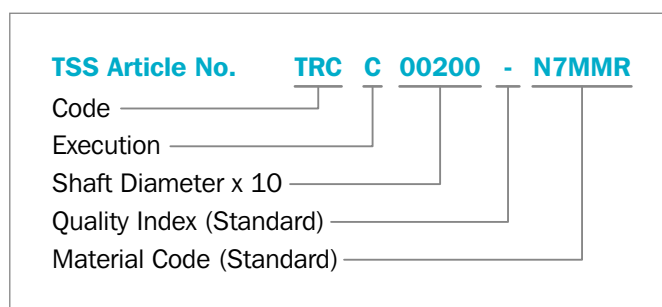
**Table 11: Preferred Series / Dimension, TSS Part Numbers**

Dimension			TSS Part No.	Material	
d ₁	d ₂	b		NBR	FKM
8	16	7	TRC000080	●	
10	22	7	TRCA00100	●	
11	17	4	TRC000110	●	
12	22	7	TRCA00120	●	
12	24	7	TRCB00120	●	
12	28	7	TRCC00120	●	
20	30	5	TRC100200		●
20	30	7	TRCA00200	●	
20	32	7	TRCB00200	●	●
20	35	7	TRCC00200	●	
20	40	7	TRCD00200	●	
20	42	7	TRC300200	●	●
20	47	7	TRCE00200	●	
24	35	7	TRCA00240	●	
25	47	7	TRCD00250	●	
30	40	7	TRCA00300	●	
30	42	7	TRCB00300	●	
30	62	7	TRCE00300	●	
35	45	7	TRC000350	●	●
35	47	7	TRCA00350	●	
35	56	12	TRC500350	●	
35	62	12	TRC700350	●	
38	52	7	TRCA00380	●	●
38	52	9	TRC400380	●	
40	52	7	TRCA00400	●	
42	55	7	TRC000420	●	
45	55	7	TRC000450	●	
45	60	10	TRC200450	●	
45	62	7	TRC300450	●	
45	62	8	TRCB00450	●	
49	65	10	TRC000490	●	
49	68	12	TRC100490	●	
50	62	7	TRC000500	●	
50	65	8	TRCA00500	●	
50	68	8	TRCB00500	●	
50	80	8	TRCD00500	●	
55	70	8	TRCA00550	●	
60	70	7	TRC000600	●	
60	72	8	TRC100600	●	
60	75	8	TRCA00600	●	
65	80	8	TRC000650	●	
68	90	10	TRCA00680		●

● In one of the preferred materials
○ In other commercial materials



Dimension			TSS Part No.	Material	
d ₁	d ₂	b		NBR	FKM
70	90	10	TRCA00700	●	
70	100	10	TRCB00700	●	
75	95	5	TRC000750	●	
75	100	10	TRCB000750	●	
76	110	13	TRC000760	●	
80	100	10	TRCA00800	●	
80	110	10	TRCB00800	●	
80	115	13	TRC200800	●	
85	100	9	TRC000850	●	
85	105	10	TRC100850	●	
90	110	8	TRC000900	●	
95	110	10	TRC300950	●	
100	115	9	TRC001000	●	
100	120	12	TRCA01000	●	
105	125	12	TRC001050	●	
110	126	9	TRC101100		●
110	130	8	TRC301100		●
120	140	13	TRC001200	●	
130	160	13	TRC001300	●	
140	160	13	TRC101400	●	
170	200	15	TRCA01700	●	
180	200	12	TRC201800	●	
180	215	16	TRC101800	●	
190	215	15	TRC001900	●	
250	280	15	TRCA02500	●	
270	310	16	TRC002700	○	
350	380	16	TRC003500	○	
370	410	15	TRC003700		○
370	410	15	TRC003700	○	
400	440	20	TRCA04000		○
440	480	20	TRCA04400	○	
460	500	20	TRCA04600	○	
460	500	20	TRCA04600		○

- In one of the preferred materials
- In other commercial materials



■ Type TRD

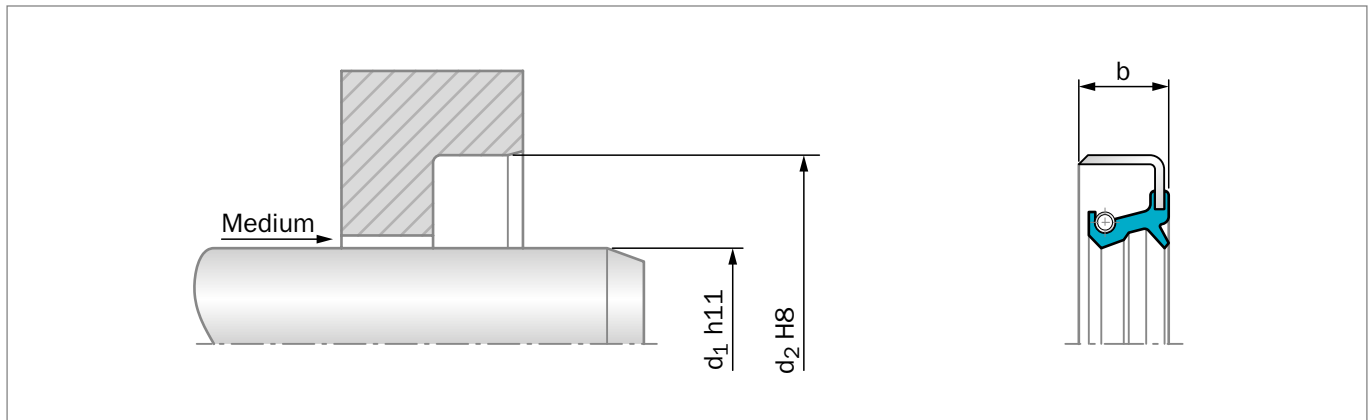

Figure 17: Installation Drawing

GENERAL DESCRIPTION

Trelleborg Sealing Solutions Type TRD are metal cased radial lip seals. The additional dust lip protects the main sealing lip against dust and other fine solid contaminants and therefore this type is recommended for use in polluted environments. To achieve a long lifetime a suitable lubricant between the two sealing lips should be applied. As the static sealing between housing and metallic shell is somewhat limited, low viscosity media can "creep". Better performance can be achieved with epoxy based resin O.D. coating. This special treatment is on request.

ADVANTAGES

- Effective protection against air side contaminants
- Good radial stiffness, especially for large diameters
- Good fitting stability avoiding pop-out of the seal
- Modern lip design provides low radial forces
- Cost effective

APPLICATION EXAMPLES

- Transmission systems (e.g. gearboxes)
- Pumps
- Electrical motors
- Machine tools
- Heavy engineering applications

OPERATING CONDITIONS

Pressure:	Up to 0.05 MPa
Temperature:	-40 °C to +200 °C (depending on material)
Speed:	Up to 10 m/s (depending on material)
Media:	Mineral and synthetic lubricants (CLP, HLP, APGL etc.)

Trelleborg Sealing Solutions has carried out several thousand compatibility tests. Please ask your local Trelleborg Sealing Solutions marketing company for details.

IMPORTANT NOTE

The above data are maximum values and cannot be used at the same time, e. g. the maximum operating speed depends on material type, pressure and temperature.



Table 12: Materials

TSS Compound Reference	Standard Compound	Temperature °C	Standard Metal Insert	Standard Spring
N7MMR	NBR (70 Shore A)	-30 °C - 100 °C	Carbon steel	Carbon steel
4N011/4NV11	NBR (75 Shore A)	-30 °C - 100 °C	Carbon steel	Carbon steel
VCBVR	FKM (70 Shore A)	-20 °C - 200 °C	Carbon steel	Stainless steel
4V012	FKM (75 Shore A)	-20 °C - 200 °C	Carbon steel	Stainless steel

Special grades and other materials (ACM, EACM, EPDM, HNBR, VMQ) on request.
Metal insert, and spring can be supplied in different materials on request.

ORDERING EXAMPLE OIL SEAL TSS TYPE

TSS Type:	D
Code:	TRD
Dimensions:	Shaft diameter 40 mm Housing diameter 52 mm Width 7 mm
Material:	NBR
Material Code:	N7MMR

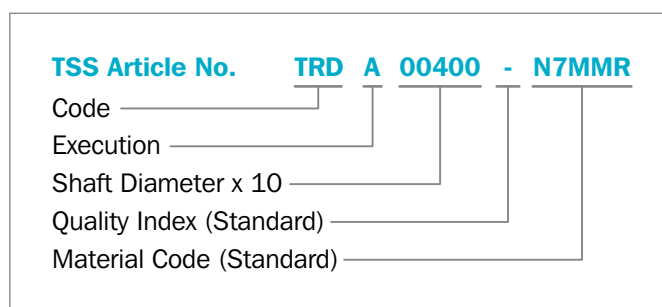

Table 13: Preferred Series / Dimension, TSS Part Numbers

Dimension			TSS Part No.	Material	
d ₁	d ₂	b		NBR	FKM
15	21	4	TRD000150	●	
25	52	7	TRDE00250	●	
35	62	12	TRD100350	●	
38	50	7	TRD000380	●	
40	54	7	TRD500400	●	
40	55	6.5	TRD100400	●	
40	55	7	TRDB00400	●	
40	90	10	TRD200400		●
41.27	57.15	7.93	TRD004127	●	
42	55	7	TRD000420	●	
42	62	7	TRD100420	●	●
45	72	8	TRDD00450	●	
48	68	10	TRD100480	●	
50	65	8	TRDA00500	●	
50	90	10	TRD200500	●	
55	90	10	TRD000550	●	
59	72	12	TRD000590	●	
65	85	12	TRD200650	●	
74	90	10	TRD000740	●	
79	120	13	TRD000790	●	
80	100	13	TRD200800	●	
100	120	12.5	TRD101000	●	
120	140	13	TRD001200	●	

Dimension			TSS Part No.	Material	
d ₁	d ₂	b		NBR	FKM
155	180	15	TRD001550	●	
240	270	15	TRDA02400	●	
270	310	16	TRD002700	●	
400	440	20	TRDA04000	●	
580	630	22	TRD005800	●	

- In one of the preferred materials
- In other commercial materials



■ Type TRB

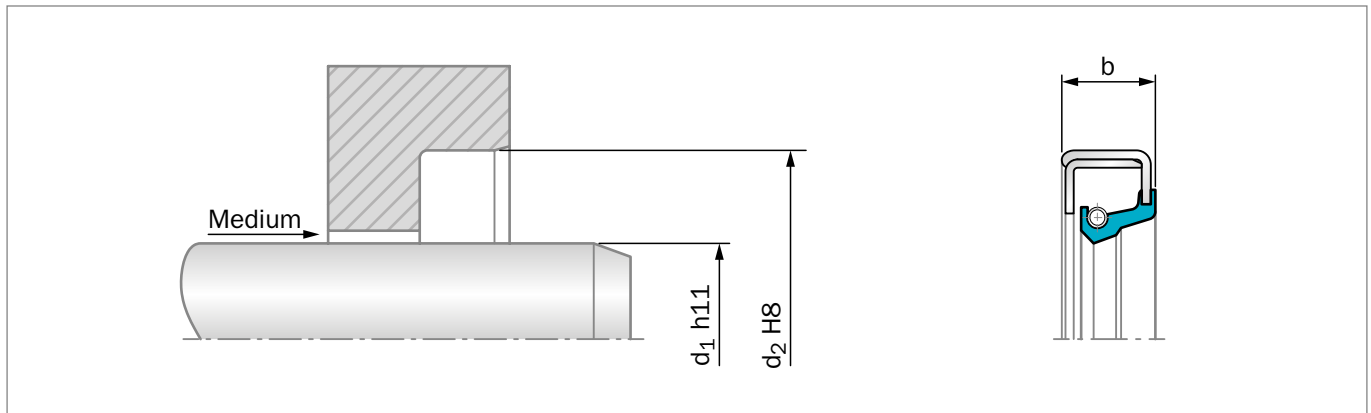

Figure 18: Installation Drawing

GENERAL DESCRIPTION

Trelleborg Sealing Solutions Type TRB are reinforced metal cased radial lip seals. The supplementary metal inner ring provides a superior stiffness. This type is not recommended for use in heavily polluted environments. As the static sealing between housing and metallic shell is limited, low viscosity media can "creep". Better performance can be achieved with epoxy based resin O.D. coating. This special treatment is on request.

ADVANTAGES

- Superior radial stiffness, especially for very large diameters
- Very good fitting stability avoiding pop-out of the seal
- Modern lip design provides low radial forces
- Cost effective
- Suitable for use in combination with axial seal (V-Ring and GAMMA-seal)
- Electrical motors
- Machine tools
- Heavy engineering applications (e.g. mills in steel industry)

OPERATING CONDITIONS

Pressure:	Up to 0.05 MPa
Temperature:	-40 °C to +200 °C (depending on material)
Speed:	Up to 10 m/s (depending on material)
Media:	Mineral and synthetic lubricants (CLP, HLP, APGL etc.)

Trelleborg Sealing Solutions has carried out several thousands compatibility tests. Please ask your local Trelleborg Sealing Solutions marketing company for details.

IMPORTANT NOTE

The above data are maximum values and cannot be used at the same time, e. g. the maximum operating speed depends on material type, pressure and temperature.



Table 14: Materials

TSS Compound Reference	Standard Compound	Temperature °C	Standard Metal Insert	Standard Spring
N7MMR	NBR (70 Shore A)	-30 °C - 100 °C	Carbon steel	Carbon steel
4N011/4NV11	NBR (75 Shore A)	-30 °C - 100 °C	Carbon steel	Carbon steel
VCBVR	FKM (70 Shore A)	-20 °C - 200 °C	Carbon steel	Stainless steel
4V012	FKM (75 Shore A)	-20 °C - 200 °C	Carbon steel	Stainless steel

Special grades and other materials (ACM, EACM, EPDM, HNBR, VMQ) on request.
Metal insert, and spring as well, can be supplied in different materials on request.

ORDERING EXAMPLE OIL SEAL TSS TYPE

TSS Type:	B
Code:	TRB
Dimensions:	Shaft diameter 45 mm Housing diameter 60 mm Width 7 mm
Material:	NBR
Material Code:	N7MMR

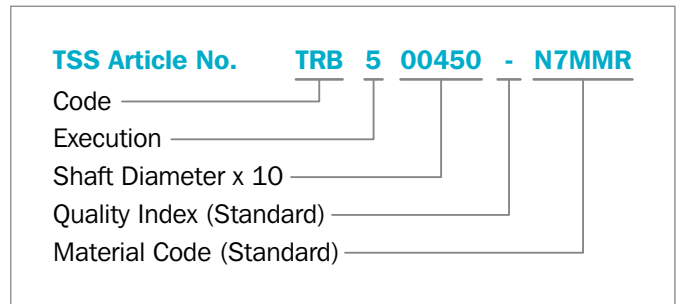

Table 15: Preferred Series / Dimension, TSS Part Numbers

Dimension			TSS Part No.	Material	
d ₁	d ₂	b		NBR	FKM
30	47	9	TRB800300	●	
30	47	10	TRB100300	●	
30	50	10	TRB300300	●	
30	62	10	TRB600300	●	
35	56	10	TRB300350		●
40	60	10	TRB200400	●	
45	60	10	TRB500450	●	
45	65	10	TRB200450	●	
45	72	10	TRB600450	●	
45	72	12	TRB000450	●	
50	72	12	TRB700500	●	○
50	90	10	TRBE00500	●	
50.80 (2.00")	73.10 (2.88")	12.70 (0.50")	TRB000508	●	
60	80	10	TRB000600	●	●
65	90	10	TRBB00650	●	
65.10 (2.56")	92.20 (3.63")	12.70 (0.50")	TRB000651	●	
66.70 (2.63")	88.50 (3.48")	12.70 (0.50")	TRB000667	●	
66.70 (2.63")	92.20 (3.63")	12.70 (0.50")	TRB100667	●	
69.85 (2.75")	90.12 (3.55")	12.70 (0.50")	TRB000698	●	
70	105	13	TRB400700	●	
73.02 (2.87")	95.40 (3.76")	12.70 (0.50")	TRB100730	●	
75	100	10	TRBB00750	●	

● In one of the preferred materials ○ In other commercial materials Values in brackets are inch sizes.



Dimension			TSS Part No.	Material	
d ₁	d ₂	b		NBR	FKM
75	100	12	TRB400750	●	○
75	105	13	TRBF00750	○	
75	115	13	TRB300750	●	
76.20 (3.00")	95.40 (3.76")	12.70 (0.50")	TRB000762	●	
76.20 (3.00")	98.60 (3.88")	11.90 (0.47")	TRB100762	●	
76.20 (3.00")	101.80 (4.00")	11.90 (0.47")	TRB200762	●	
80	100	10	TRBA00800	●	
80	100	12	TRB000800	●	●
80	110	12	TRB200800	●	
80	120	13	TRB400800	●	
85	130	13	TRB400850	●	
85.72 (3.37")	108.05 (4.25")	12.70 (0.50")	TRB000857	●	
90	130	13	TRB500900	●	
95	120	12	TRBA00950		●
98.42 (3.87")	120.81 (4.76")	12.70 (0.50")	TRB000984	●	
98.42 (3.87")	127.10 (5.00")	11.91 (0.47")	TRB100984	●	
100	120	12	TRBA01000		○
100	120	13	TRB101000	●	
101.60 (4.00")	127.10 (5.00")	12.70 (0.50")	TRB101016	●	●
114.30 (4.50")	139.85 (5.50")	12.70 (0.50")	TRB001143	●	
125	150	15	TRB301250	●	
127.00 (5.00")	158.90 (6.25")	12.70 (0.50")	TRB001270	●	
130	160	15	TRB401300	○	
130	180	15	TRB301300	●	
140	160	13	TRB001400	●	
140	190	15	TRB301400	●	
145	165	13	TRB001450	●	
145	170	13	TRB101450	●	
145	180	15	TRB301450	●	
148	170	15	TRB001480	●	
150	180	15	TRBA01500		○
160	180	15	TRB001600	●	
160	190	13	TRB001600	●	●
165.10 (6.50")	193.88 (7.63")	15.75 (0.62")	TRB001651	●	
174.60 (6.87")	200.23 (7.88")	15.90 (0.63")	TRB001746	●	
180	210	15	TRBA01800	●	
180	220	16	TRB001800	●	
190	220	15	TRBA01900	○	
210	240	15	TRBA02100		○
220	250	15	TRB002200	●	
230	260	15	TRBA02300	○	
240	270	15	TRBA02400	●	●
250	280	15	TRBA02500	●	

● In one of the preferred materials

○ In other commercial materials

Values in brackets are inch sizes.



Dimension			TSS Part No.	Material	
d ₁	d ₂	b		NBR	FKM
260	290	16	TRB002600	○	●
270	310	16	TRB102700		○
280	310	16	TRB002800	○	
280	320	20	TRBA02800	○	
290	330	18	TRB202900	○	
300	332	16	TRB003000	●	
300	340	20	TRBA03000	○	○
310	350	18	TRB003100	●	
320	360	18	TRB103200	●	
325	365	16	TRBA03250	●	
330	370	18	TRB003300	○	
340	372	16	TRB003400	○	
340	380	20	TRBA03400	●	●
360	400	18	TRB003600	●	
360	400	20	TRBA03600		●
374.65 (14.75")	419.00 (16.50")	22.20 (0.87")	TRB003746	●	
380	420	20	TRBA03800	●	
390	430	18	TRB003900	○	○
400	440	20	TRBA04000	○	○
440	470	20	TRB004400	○	
460	500	20	TRBA04600	●	
467	510	20	TRB004670	●	
490	530	20	TRB004900	○	
500	540	20	TRBA05000	○	
500	540	20	TRBA05000		○
500	550	22	TRB005000	○	
530	570	20	TRB005300	○	
560	610	20	TRB005600		○
560	610	20	TRB005600	○	
580	620	20	TRB105800	○	
600	640	20	TRB006000	○	○
600	640	20	TRB006000	○	
620	660	20	TRB006200	○	
650	690	25	TRB206500	○	
700	750	25	TRB007000	○	
700	764	25	TRB107000	○	
720	780	25	TRB207200		○
740	780	20	TRB107400		○
760	800	20	TRB107600		○
960	1000	20	TRB009600	○	
1120	1170	20	TRB011200		○
1120	1170	20	TRB011200		○

● In one of the preferred materials

○ In other commercial materials

Values in brackets are inch sizes.



■ Type TRF

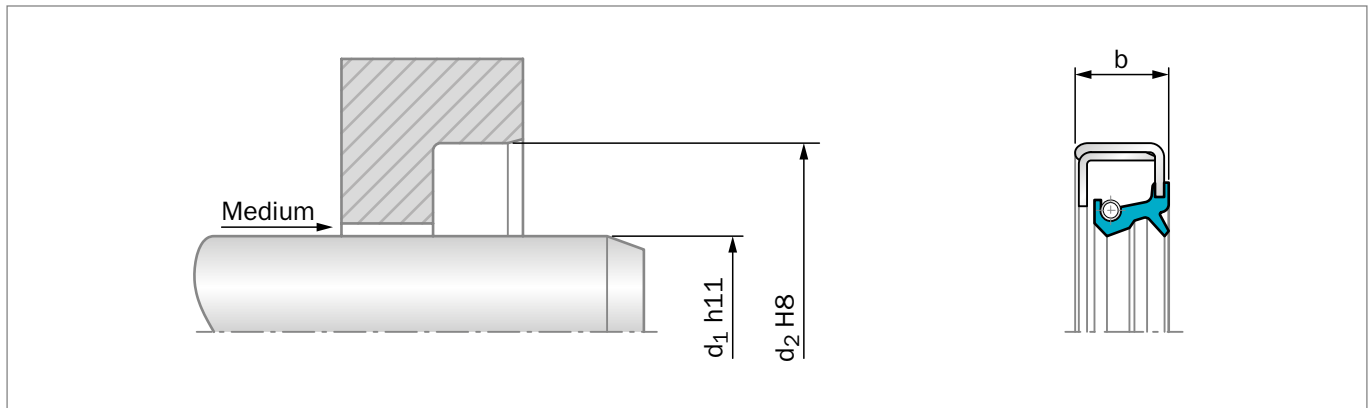

Figure 19: Installation Drawing

GENERAL DESCRIPTION

Trelleborg Sealing Solutions Type TRF are reinforced metal cased radial lip seals with dust lip. The supplementary metal inner ring provides a superior stiffness. This type is recommended for use in heavily polluted environments. To achieve a long lifetime a suitable lubricant between the two sealing lips should be applied. As the static sealing between housing and metallic shell is limited, low viscosity media can "creep". Better performance can be achieved with epoxy based resin O.D. coating. This special treatment is on request.

ADVANTAGES

- Superior radial stiffness, especially for very large diameters
- Very good fitting stability avoiding pop-out of the seal
- Modern lip design provides low radial forces
- Cost effective
- Suitable for use in combination with axial seal (V-Ring and GAMMA-seal)

APPLICATION EXAMPLES

- Transmission systems (e.g. gearboxes)
- Pumps
- Electrical motors
- Machine tools
- Heavy engineering applications (e.g. mills in steel industry)

OPERATING CONDITIONS

Pressure:	Up to 0.05 MPa
Temperature:	-40 °C to +200 °C (depending on material)
Speed:	Up to 10 m/s (depending on material)
Media:	Mineral and synthetic lubricants (CLP, HLP, APGL etc.)

Trelleborg Sealing Solutions has carried out several thousand compatibility tests. Please ask your local Trelleborg Sealing Solutions marketing company for details.

IMPORTANT NOTE

The above data are maximum values and cannot be used at the same time, e. g. the maximum operating speed depends on material type, pressure and temperature.



Table 16: Materials

TSS Compound Reference	Standard Compound	Temperature °C	Standard Metal insert	Standard spring
N7MMR	NBR (70 Shore A)	-30 °C - 100 °C	Carbon steel	Carbon steel
4N011/4NV11	NBR (75 Shore A)	-30 °C - 100 °C	Carbon steel	Carbon steel
VCBVR	FKM (70 Shore A)	-20 °C - 200 °C	Carbon steel	Stainless steel
4V012	FKM (75 Shore A)	-20 °C - 200 °C	Carbon steel	Stainless steel

Special grades and other materials (ACM, EACM, EPDM, HNBR, VMQ) on request.
Metal insert, and spring, can be supplied in different materials on request.

ORDERING EXAMPLE OIL SEAL TSS TYPE

TSS Type:	F
Code:	TRF
Dimensions:	Shaft diameter 110 mm Housing diameter 140 mm Width 13 mm
Material:	NBR
Material Code:	N7MMR

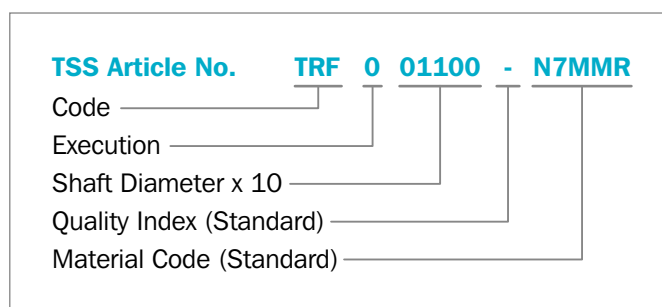

Table 17: Preferred Series / Dimension, TSS Part Numbers

Dimension			TSS Part No.	Material	
d ₁	d ₂	b		NBR	FKM
35	52	9	TRF000350	●	
40	55	9	TRF000400	●	
41	53	7	TRF000410	●	
50	65	10	TRF300500	●	
50	80	10	TRF100500	●	
60	80	8	TRFB00600	●	
90	130	13	TRF100900	●	
100	130	13	TRF101000		○
105	140	13	TRF001050		●
110	140	13	TRF001100	●	●
115	140	11	TRF001150	●	
120	140	13	TRF001200		●
125	150	12	TRFA01250		●
130	155	10	TRF001300	●	
130	170	15	TRF101300	●	
132	160	13	TRF001320	●	
140	170	15	TRFA01400	●	
148	170	14.5	TRF101480	●	●
148	170	15	TRF001480	●	
150	180	15	TRFA01500	●	
170	200	15	TRFA01700	●	
200	225	15	TRF102000	○	
240	270	15	TRFA02400	○	●

Dimension			TSS Part No.	Material	
d ₁	d ₂	b		NBR	FKM
240	280	16	TRF002400	●	
265	290	16	TRF002650		○
275	310	16	TRF102750		○
380	420	20	TRF003800	●	●
467	510	20	TRF004670	○	
920	970	20	TRF009200		○

- In one of the preferred materials
- In other commercial materials



■ Non Standard Radial Oil Seals

When standard seals in accordance with DIN 3760/3761 (Table 3) can not fulfill the technical requirement of the application, special seals are required.

Special seals are used for high speed, medium- or high-pressure or heavy duty applications, for example.

If a standard or special seal design will be used, the media compatibility with the compound needs to be given (see Figure 13).

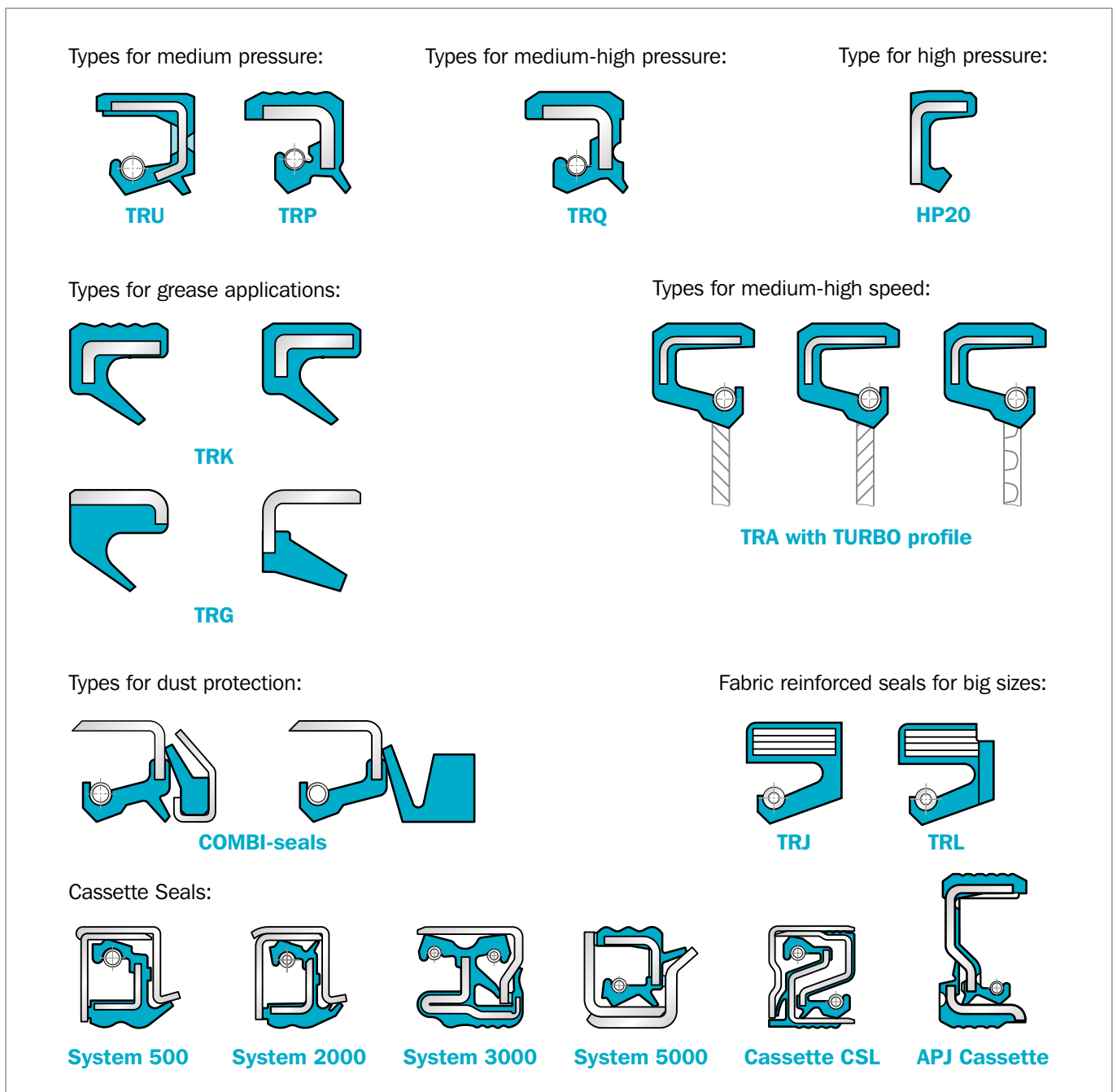

Figure 20: Selection of special radial seals



■ Type TRU – Medium Pressure Oil Seal

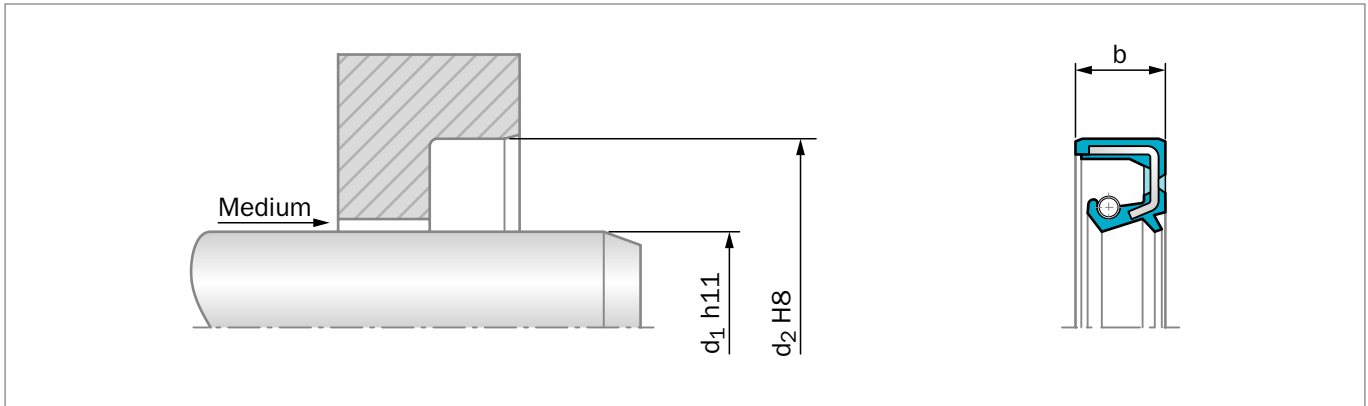

Figure 21: Installation Drawing

GENERAL DESCRIPTION

Trelleborg Sealing Solutions Type TRU is a seal with completely rubber covered outer diameter. This type of seal is designed with an extended metallic support of the diaphragm that allows pressures up to 0.5 MPa. In order to avoid a "pop-out" of the seal, we suggest to fit an axial retainer (e.g. circlip, shoulder, etc.). The additional dust lip protects the main sealing lip against dust and other fine solid contaminants and therefore this type is recommended for use in polluted environments. To achieve a long lifetime a suitable lubricant between the two sealing lips should be applied.

ADVANTAGES

- Good static sealing
- Compensation of different thermal expansion
- Reduced risk of fretting corrosion
- Up to 0.5 MPa pressure at moderate peripheral speed
- Effective protection against air side contaminants
- No need for Back-up Ring

APPLICATION EXAMPLES

- Transmission systems (e.g. gearboxes)
- Pumps
- Hydraulic motors
- Machinery industry

OPERATING CONDITIONS

Pressure:	Up to 0.05 MPa
Temperature:	-40 °C to +200 °C (depending on material)
Speed:	Up to 10 m/s (depending on material)
Media:	Mineral and synthetic lubricants (CLP, HLP, APGL etc.)

Trelleborg Sealing Solutions has carried out several thousands compatibility tests. Please ask your local Trelleborg Sealing Solutions marketing company for details.

IMPORTANT NOTE

The above data are maximum values and cannot be used at the same time, e. g. the maximum operating speed depends on material type, pressure and temperature.

**Table 18: Materials**

Standard Material*	TSS Material code	Standard Metal Insert**	Standard Spring**
NBR (70 Shore A)	N7MMR	Carbon steel	Carbon steel
FKM (70 Shore A)	VCBVR	Carbon steel	Stainless steel

* Special grades and other materials (ACM, EACM, EPDM, HNBR, VMQ) on request.

** Metal insert and spring, can be supplied in different materials on request.

ORDERING EXAMPLE OIL SEAL TSS TYPE

TSS Type:	U	
Code:	TRU	
Dimensions:	Shaft diameter	40 mm
	Housing diameter	52 mm
	Width	7 mm
Material:	NBR	
Material Code:	N7MMR	

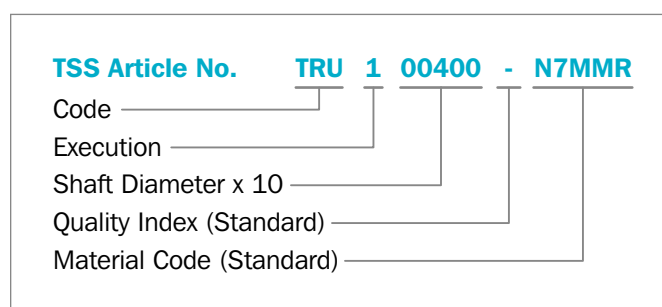
**Table 19: Preferred Series / Dimension, TSS Part Numbers**

Dimension			TSS Part No.	Material		Dimension			TSS Part No.	Material	
d ₁	d ₂	b		NBR	FKM	d ₁	d ₂	b		NBR	FKM
8	16	6	TRU100080	●		35	50	7.5	TRU300350	●	
8	22	7	TRU000080	●	●	35	52	6	TRU100350		●
10	22	6	TRU000100	●		38	62	12	TRU000380	●	
12	22	6	TRU200120	●		40	55	8	TRU200400	●	●
12	22	7	TRU000120	●		40	62	6	TRU400400	●	●
15	25	6	TRU100150	●		42	56	5.5	TRU100420		●
15	30	7	TRU000150	●		45	62	7	TRU000450		●
16	28	6	TRU000160		●	45	65	8	TRU100450	●	
20	35	6	TRU300200	●		45	72	8	TRUD00450	●	
20	40	6	TRU000200	●		46	60	6	TRU000460	●	●
22	40	7	TRU000220	●	●	47	62	7	TRU000470	●	
22	42	7	TRU200220	●		50	65	7	TRU200500		●
22	47	7	TRU000220		●	50	65	8	TRU200500	●	
23	40	6	TRU000230	●	●	50	68	8	TRU000500	●	
25	37	6	TRU100250	●		55	72	7	TRU000550	●	●
25	40	7	TRU000250	●	●	55	72	8	TRU200550	●	
27	42	7	TRU100270	●		55	75	7	TRU100550		●
28	40	6	TRU000280		●	60	75	8	TRU100600		●
28	41	6	TRU200280		●	60	80	7	TRU000600	●	●
28	47	7	TRU100280		●	65	85	10	TRU000650	●	
29	40	6	TRU000290	●		70	90	7	TRU100700	●	●
30	42	6	TRU000300	●	●	80	100	7	TRU000800	●	
32	47	6	TRU000320		●						
35	47	7	TRU000350		●						

● In one of the preferred materials
○ In other commercial materials



Dimension			TSS Part No.	Material	
d ₁	d ₂	b		NBR	FKM
90	110	7.5	TRU000900		●
90	110	13	TRU200900		●
90	125	12	TRU100900	●	
95	120	12	TRU000950	●	
100	120	12	TRUA01000	●	
120	150	12	TRU101200	●	
135	165	15	TRU001350	●	
140	160	10	TRU201400	●	●
140	170	12	TRU001400	●	
160	185	8.5	TRU101600	●	
160	190	15	TRU001600	●	
200	230	15	TRU002000	●	

- In one of the preferred materials
- In other commercial materials



■ Type TRP – Medium Pressure Oil Seal

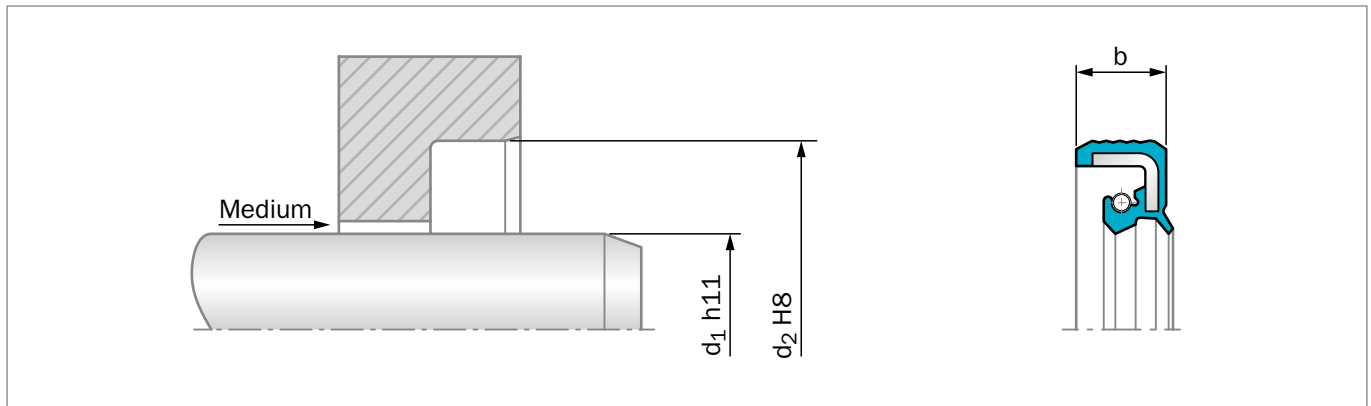

Figure 22: Installation Drawing

GENERAL DESCRIPTION

Trelleborg Sealing Solutions type TRP are seals with a completely rubber covered outer diameters. This type of seal is designed for pressures up to 0.5 MPa. In order to avoid a "pop-out" of the seal, we suggest to fit an axial retainer (e.g. circlip, shoulder, etc.) The additional dust lip protects the main sealing lip against dust and other fine solid contaminants and therefore this type is recommended for use in polluted environments. To achieve a long lifetime a suitable lubricant between the two sealing lips should be applied. The OD can be provided flat or waved.

ADVANTAGES

- Good static sealing
- Compensation of different thermal expansion
- Reduced risk of fretting corrosion
- Up to 0.5 MPa pressure at moderate peripheral speed
- Low lip and shaft wear at low pressure run
- Effective protection against air side contaminants
- No need for Back-up Ring

APPLICATION EXAMPLES

- Transmission systems (e.g. gearboxes)
- Pumps
- Hydraulic motors
- Machinery industry

OPERATING CONDITIONS

Pressure:	Up to 0.05 MPa
Temperature:	-40 °C to +200 °C (depending on material)
Speed:	Up to 10 m/s (depending on material)
Media:	Mineral and synthetic lubricants (CLP, HLP, APGL etc.)

Trelleborg Sealing Solutions has carried out several thousands compatibility tests. Please ask your local Trelleborg Sealing Solutions marketing company for details.

IMPORTANT NOTE

The above data are maximum values and cannot be used at the same time, e. g. the maximum operating speed depends on material type, pressure and temperature.



Table 20: Materials

TSS Compound Reference	Standard Compound	Temperature °C	Standard Metal insert	Standard spring
N7MMR	NBR (70 Shore A)	-30 °C - 100 °C	Carbon steel	Carbon steel
4N011/4NV11	NBR (75 Shore A)	-30 °C - 100 °C	Carbon steel	Carbon steel
VCBVR	FKM (70 Shore A)	-20 °C - 200 °C	Carbon steel	Stainless steel
4V012	FKM (75 Shore A)	-20 °C - 200 °C	Carbon steel	Stainless steel

Special grades and other materials (ACM, EACM, EPDM, HNBR, VMQ) on request.
Metal insert and spring, can be supplied in different materials on request.

ORDERING EXAMPLE OIL SEAL TSS TYPE

TSS Type:	P	
Code:	TRP	
Dimensions:	Shaft diameter	50 mm
	Housing diameter	72 mm
	Width	7 mm
Material:	NBR	
Material Code:	N7MMR	

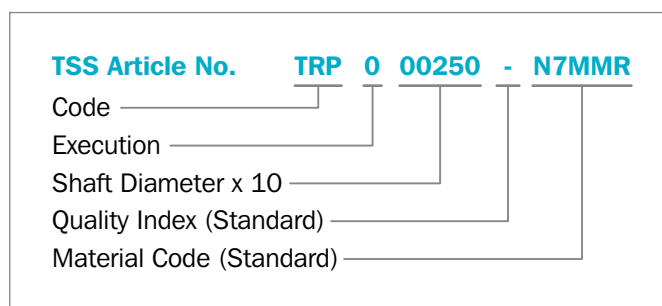

Table 21: Preferred Series / Dimension, TSS Part Numbers

Dimension			TSS Part No.	Material	
d ₁	d ₂	b		NBR	FKM
8	22	6	TRP000080	●	
10	22	7	TRP000100	●	
10	27	7	TRP100100		●
11	19	6	TRP000110	●	
12	22	6	TRP000120	●	●
13	22	5	TRP000130		●
16	26	7	TRP000160	●	
17	30	7/7.9	TRP000170		●
18	30	7	TRP000180		●
18	35	7	TRPC00180		●
19	27	5	TRP000190	●	
19	32	5	TRP200190	●	
19.5	30	6	TRP000195	●	●
21.5	30	6	TRP000215	●	●
21.5	33	6	TRP100215		●
20	35	6	TRP100200		●
20	40	7	TRP000200		●
22	32	6	TRP100220		●
22	35	6	TRP200220	●	
22	40	6	TRP000220		●
25	35	6	TRP100250	●	●
25	40	7	TRP000250	●	●
28	40	6	TRP000280		●
28	40	9	TRP100280	●	
30	42	6	TRP000300	●	

Dimension			TSS Part No.	Material	
d ₁	d ₂	b		NBR	FKM
33	45	5	TRP000330	●	●
35	47	6	TRP100350	●	
35	52	6	TRP000350	●	●
35	52	7	TRP000350	●	
36	48	5.5	TRP000360	●	
40	55	7	TRPB00400	●	●
40	62	6	TRP100400	●	●
40	67	7	TRP000400		●
45	62	7	TRP000450	●	
50	72	7	TRP000500	●	●
55	70	7	TRP000550	●	●
60	80	7	TRP000600	●	●
70	90	7	TRP000700	●	●
80	100	7/8	TRP000800	●	●
85	105	7.5	TRP000850	●	
85	110	8	TRP100850		●
90	110	7.5	TRP000900		●
95	120	12	TRP000950	●	
100	120	7.5	TRP001000		●
105	130	7.5	TRP101050		●
124	139	8	TRP001240		●
190	220	12	TRP001900	●	

● In one of the preferred materials
○ In other commercial materials



■ Type TRQ – Medium-high Pressure Oil Seal

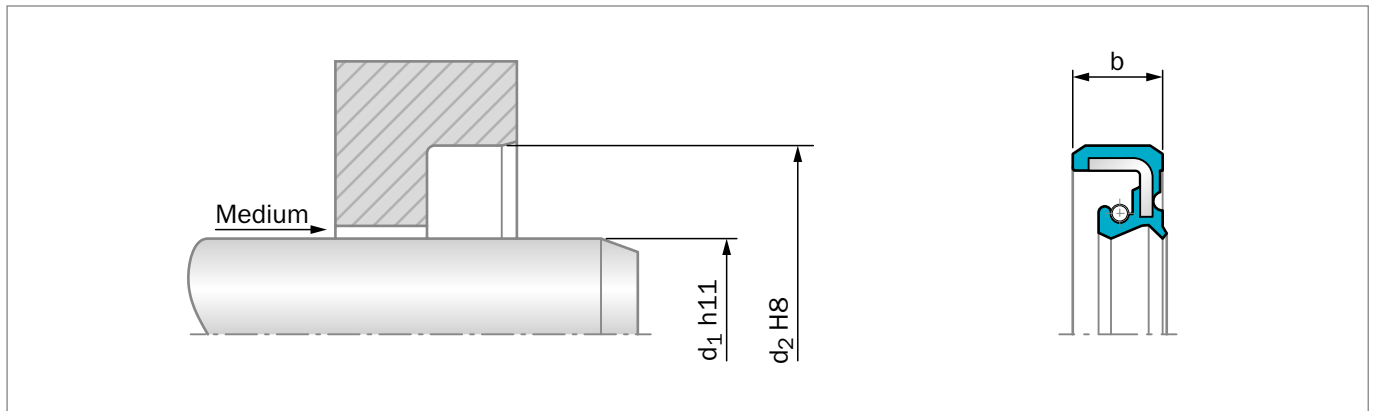

Figure 23: Installation Drawing

GENERAL DESCRIPTION

STEFA Type 12 CC (TRQ_D) is a seal with a completely rubber covered outer diameter. This type of seal is designed for pressures up to 1 MPa. In order to avoid a "pop-out" of the seal, we suggest to fit an axial retainer (e.g. circlip, shoulder, etc.). The additional dust lip protects the main sealing lip against dust and other fine solid contaminants and therefore this type is recommended for use in polluted environments. To achieve a long lifetime a suitable lubricant between the two sealing lips should be applied. The OD can be provided flat or waved.

ADVANTAGES

- Good static sealing
- Compensation of different thermal expansion
- Reduced risk of fretting corrosion
- Up to 1 MPa pressure at low peripheral speed
- Effective protection against air side contaminants
- No need of Back-up Ring.

APPLICATION EXAMPLES

- Transmission systems (e.g. gearboxes)
- Pumps
- Hydraulic motors
- Machinery industry

OPERATING CONDITIONS

Pressure:	Up to 1 MPa
Temperature:	-40 °C to +200 °C (depending on pressure and material)
Speed:	Up to 5 m/s (depending on material)
Media:	Mineral and synthetic lubricants (CLP, HLP, APGL etc.)

Trelleborg Sealing Solutions has carried out several thousands compatibility tests. Please ask your local Trelleborg Sealing Solutions marketing company for details.

IMPORTANT NOTE

The above data are maximum values and cannot be used at the same time, e. g. the maximum operating speed depends on material type, pressure and temperature.



Table 22: Materials

Standard Material*	TSS Material Code	Standard Metal Insert**	Standard Spring**
NBR (75 Shore A)	4N011	Carbon steel	Carbon steel
FKM (75 Shore A)	4V012	Carbon steel	Stainless steel

* Special grades and other materials (ACM, EACM, EPDM, HNBR, VMQ) on request.

** Metal insert and spring, can be supplied in different materials on request.

ORDERING EXAMPLE OIL SEAL STEFA TYPE

STEFA Type:	12CC	
Code:	TRQ_D	
Dimensions:	Shaft diameter	24 mm
	Housing diameter	40 mm
	Width	6 mm
Material:	NBR 1452	
Material Code:	4N011	

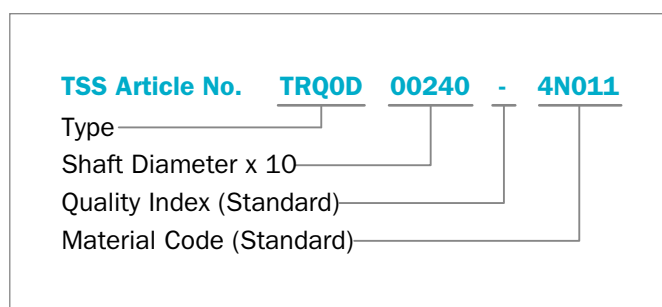

Table 23: Preferred Series / Dimension, TSS Part Numbers

Dimension			TSS Part No.	Material	
d ₁	d ₂	b		NBR	FKM
24	40	6	TRQ0D0240	●	
27	44	7	TRQ0D0270	●	●
32	47	6	TRQ0D0320		●
40	55	7	TRQBD0400		●
40	62	5,5	TRQ0D0400	●	
40	62	6	TRQ1D0400	●	
50	72	6,5	TRQ1D0500	●	
50	72	7	TRQ0D0500		●
60	80	7	TRQ0D0600		●
60	80	6,5	TRQ1D0600	●	
60	80	8	TRQ2D0600	●	
70	90	7	TRQ0D0700		●
130	160	11	TRQ0D1300	●	●

● In one of the preferred materials

○ In other commercial materials



■ Type HP20 – High Pressure Oil Seal

GENERAL DESCRIPTION

HP20 is a patented Rotary Oil Seal providing an optimal sealing solution for hydraulic devices with rotating shafts and working at pressures up to 20 MPa.

APPLICATION EXAMPLES

- Hydraulic drive motors
- Material handling
- Forestry and agriculture machinery
- Construction machinery
- Turf care
- Scissor lifts
- Winches

SPECIAL FEATURES

Prevention of lip extrusion at high pressures, thanks to the metal retainer bonded to the elastomeric lip Patented pressure-balancing sealing lip design, provides a stable contact of the sealing lip on the shaft Heat dissipation thanks to the contact between the metal retainer and the housing plate

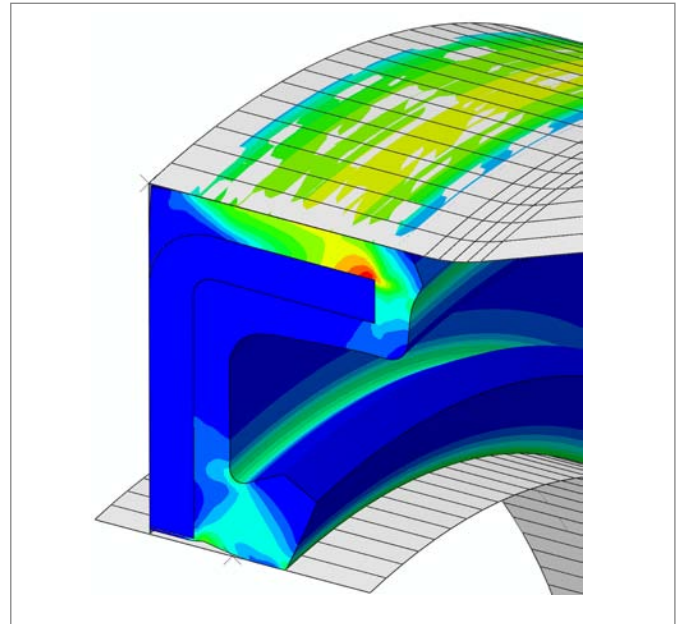

Figure 24: FEA at high pressure

MATERIALS AND OIL COMPATIBILITY

HP20 seal is composed of a metal retainer and an elastomeric sealing lip. The sealing lip is made from Trelleborg proprietary elastomers specifically developed for working in high pressure hydraulic oil; standard available grades are Hydrogenated-Nitrile HNBR, Fluoroelastomer FKM, and high grade Fluoroelastomer FKM "XploR"; other special elastomer compounds can be used according to customer specifications.

The HNBR version operates with mineral oils according to DIN 51524-2 cat. HLP or ISO 11158 cat. HM (ISO 6743/4 cat. L-HM) or ISO VG46 – BDS ISO 3448, purity class 16/13 – ISO4406 -1999.

FKM versions are also applicable with bio-degradable hydraulic oils (compatibility testing is recommended).



WORKING CONDITIONS

Speed and pressure working conditions

The main factors affecting the performance of the HP20 seals are the pressure and speed combination, the oil type, temperature and flow amount.

The rated pressure vs. shaft speed working conditions are given by graph (Figure 25).

Several tests have been performed to define this curves, by using an hydraulic mineral oil ISO VG46, an oil flow above 2 liters per minute, an oil temperature of 60°C and an STBM eccentricity below 0.1 mm.

The real performance of HP20 seals in the field, are affected by other parameters that are not possible to reproduce in the

laboratory, like for example the shaft accelerations, the thermal conductivity of the shaft and of the bore, the pollution in the oil, the vibrations in the system and the pressure transients in the oil. Trelleborg Sealing Solutions recommends the customers always perform a test on the device in the normal and worst case, to validate its functionality.

Trelleborg Sealing Solutions is available to evaluate special working conditions and suggest the best configuration of the HP20 seal in terms of compound, metal retainer and sealing lip shape.

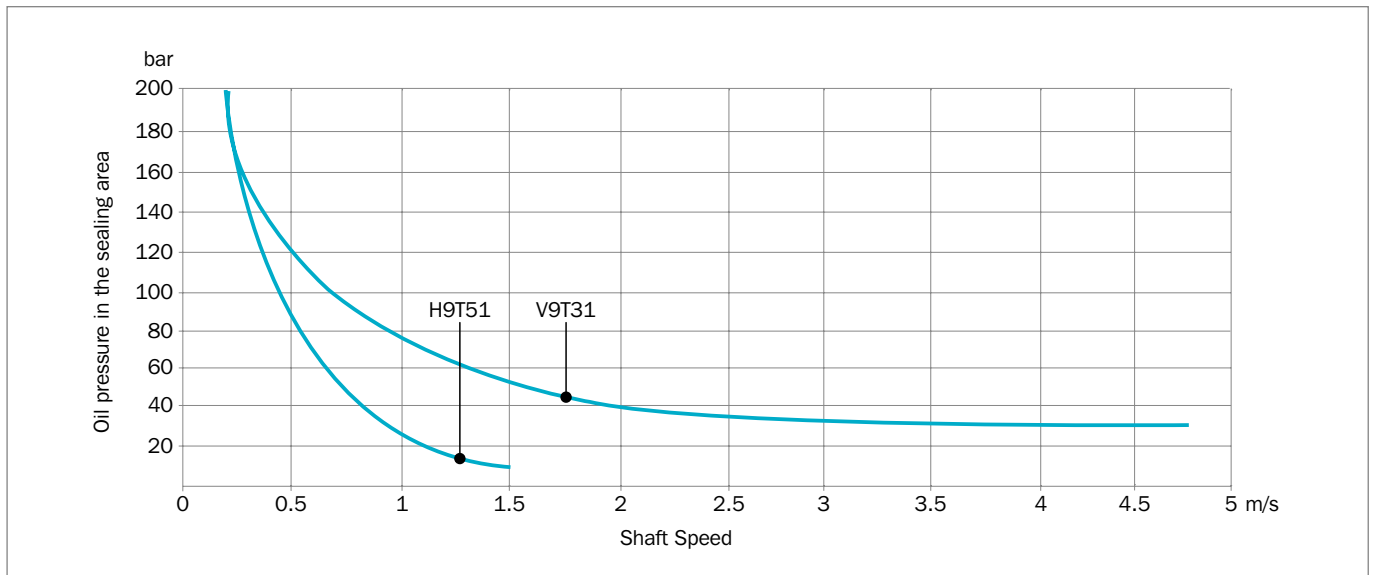

Figure 25: HP20 Rated Working Conditions

Working eccentricity

HP20 seals, in order to work properly, requires a “shaft to bore misalignment” (STBM) to be kept below the threshold given in the graph.

The STBM needs to be obtained with proper tolerance study on the motor design, a proper machining and installation, and appropriate bearings capable to support axial loads on the shaft and wear due to age.

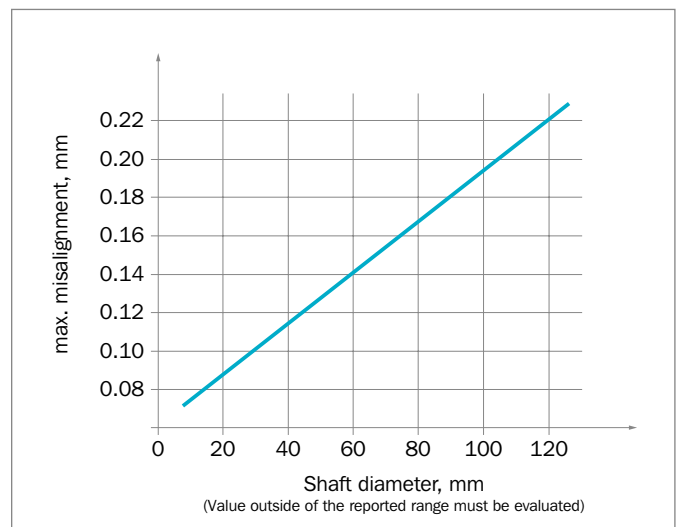

Figure 26: Shaft to bore misalignment



HOUSING AND SHAFT DESIGN

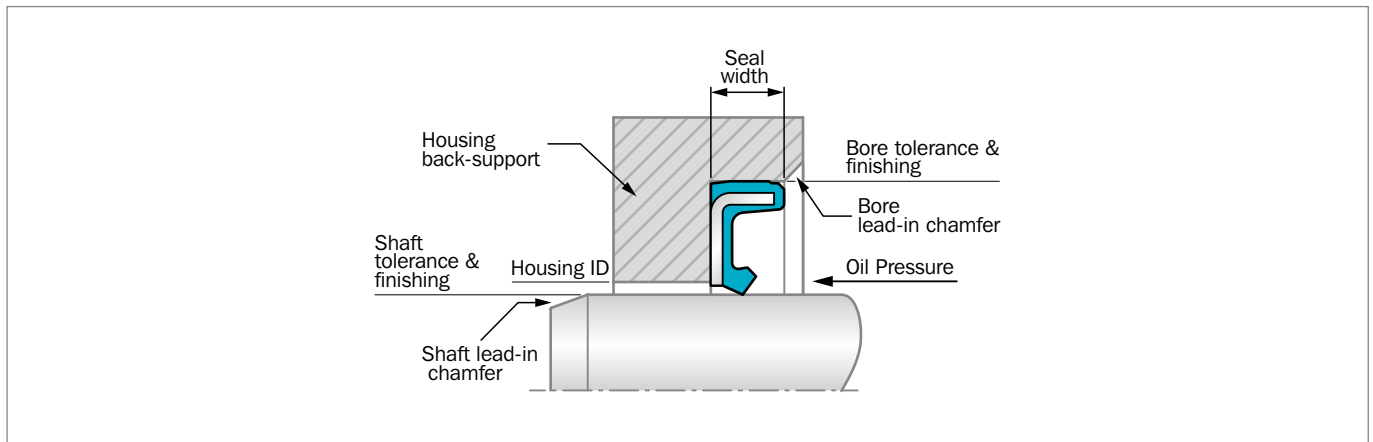

Figure 27: Installation Drawing

Shaft materials

HP-20 seals are made with mild steel or chrome steel.

Shaft hardness

Required hardness is Rockwell-C 55; recommended 60 HRC.

Shaft finish

Required roughness is between 0.2 and 0.5 micrometers Ra with no machine lead. The most accepted method of obtaining this finish is plunge grinding.

Shaft geometry

HP20 seals are designed to work with shaft tolerance h11. Shaft chamfer and must be aligned to table below and sharp edges radiused to avoid damaging of sealing lips during installation.

The shaft surfaces over which the seal lip slides during installation should be kept smooth and free from any burrs or rough spots.

Table 24: Shaft lead-in chamfers

Ø Shaft mm	Shaft Chamfer Length mm	Shaft Chamfer Angle deg
16 ÷ 30	2,00 (±0,10)	20°
30 ÷ 40	2,20 (±0,10)	20°
40 ÷ 50	2,50 (±0,10)	20°
50 ÷ 70	3,20 (±0,10)	20°
70 ÷ 120	4,50 (±0,12)	20°

Housing materials

HP20 benefits from being assembled into an highly thermally conductive material housing.

Bore finishing

A finish of 2.5 micrometers Ra or better is recommended.

Bore geometry

- Bore tolerance is H8
- Bore leading chamfer according to table below
- Housing must be provided with a back-support for the HP20 seal to retain the pressure force and dissipate heat from the back face of the HP20 seal; the back support must have same ID as the HP20 metal retainer

Shaft to bore misalignment

- The maximum assembly and working misalignment must be according to graph (Figure 27)

Table 25: Bore lead-in chamfers

Ø Shaft mm	Seal Width mm	Bore Chamfer Length mm	Bore Chamfer Angle deg
16 ÷ 30	4,2 - 5,5 (±0,20)	1,00	15°
30 ÷ 40	4,5 - 6,5 (±0,20)	1,20	15°
40 ÷ 50	5,5 - 7,0 (±0,20)	1,30	15°
50 ÷ 70	6,0 - 7,5 (±0,25)	1,50	15°
70 ÷ 120	7,5 - 9,5 (±0,30)	1,70	15°



INSTALLATION

HP20 seals are usually assembled first on a metal housing, and then the shaft is fitted inside the seal from the air side or from the oil side depending on device and bearing positioning.

During assembly operation, it's necessary to apply a good layer of grease to both the sealing lip and the shaft, in order to:

- provide a smooth sliding of the lip on the shaft during assembly
- provide a pre-lubrication during the first turns of the shaft

The type of grease recommended for this operation is an LS-EP2 grease.

It's very important to align the cover and the shaft, with a precentering system to avoid stress on the sealing lip. While fitting the shaft inside the seal, gently rotate the shaft in order to reduce the assembly tension created during installation process.

Never install a seal over splines or keyways without using a special installation tool that protect the seal lip from getting in touch with sharp edges.

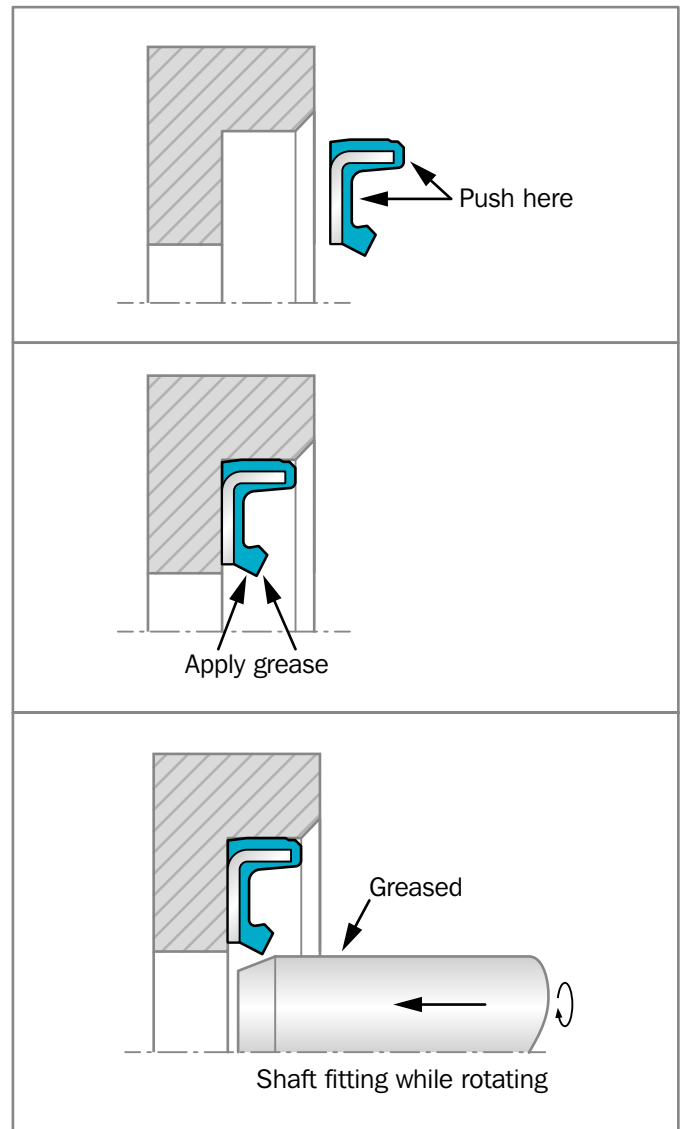

Figure 28: Installation Instructions

**Table 26: Materials**

TSS Compound	Rated hydraulic oil viscosity	Minimum working environment temperature	Maximum working oil temperature	Chemical compatibility with hydraulic oils
H9T51 Low temperature HNBR	46 cSt	-30° C / -22° C	+80° C / +176° F	Mineral oils
V9T31 FKM XploR	46 cSt	-30° C / -22° C	+120° C / +248° F	Mineral oils, synthetic oils, bio-degradable oils

Table 27: Preferred Series / Dimension, TSS Part Numbers

Dimension			TSS Part No.	Material	
d ₁	d ₂	b		H9T51	V9T31
16,9	28	5,35	TRTOA0169	●	●
28,56	38	4,72	TRT1A0286	●	●
28,56	42	4,72	TRTOA0286	●	●
31,75	41,28	5,00	TRTOA0318		●
35	48	4,72	TRTOA0350	●	●
38,1	50	4,29	TRTOA0381	●	●
45	65	4,45	TRTOA0450	●	●
50	70	5,08	TRTOA0500	●	●
60	80	5,97	TRTOA0600	●	●
72	95	7,00	TRTOA0720	●	

Please ask for sizes and materials not included in the present list.

ORDERING EXAMPLES OF HP20 SEALS

ROS Type:	HP20	
Design Code:	TRT	
Dimensions:	Shaft diameter	35 mm
	Housing diameter	48 mm
	Width	4,72 mm
Size Code:	TRTOA0350	
Elastomer:	H9T51	
Material Code:	4HH1	

ROS Type:	HP20	
Design Code:	TRT	
Dimensions:	Shaft diameter	28,56 mm
	Housing diameter	42 mm
	Width	4,72 mm
Size Code:	TRTOA0286	
Elastomer:	V9T31	
Material Code:	4VT4	

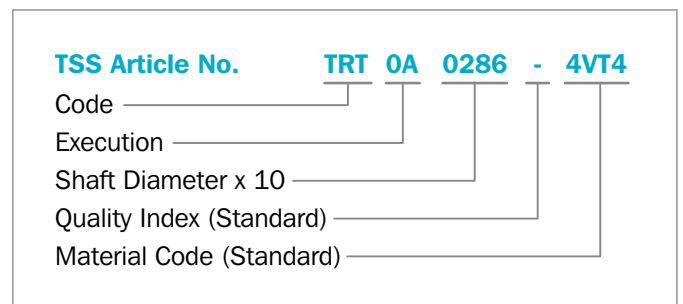
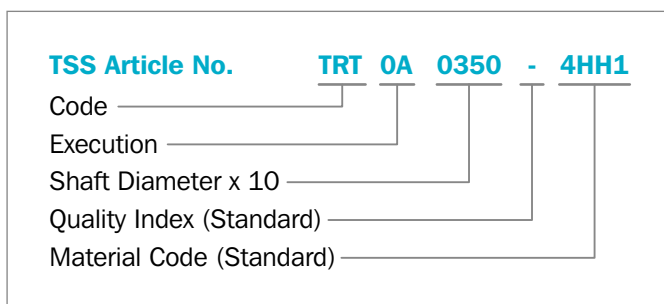



■ Type TRK – Medium Grease

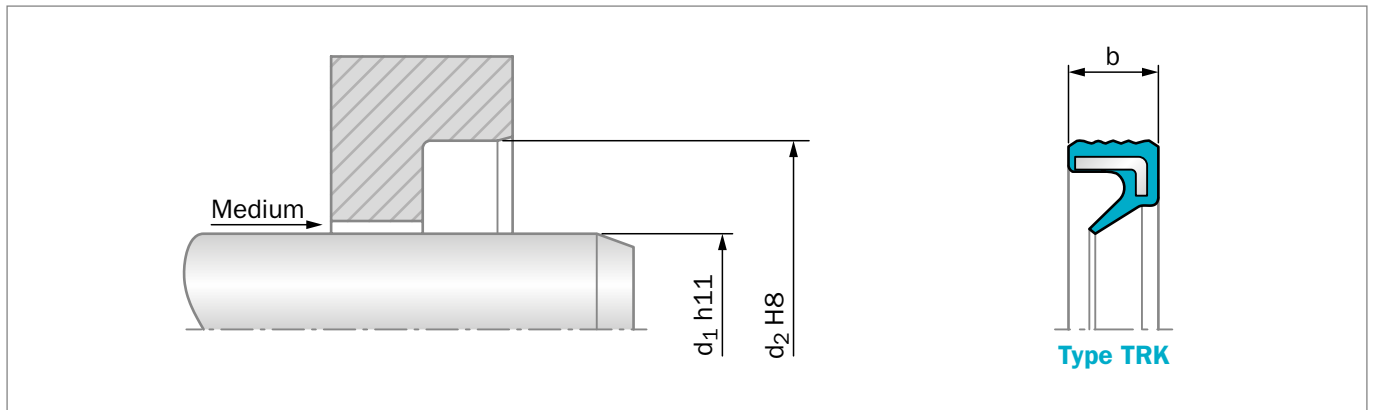

Figure 29: Installation Drawing

GENERAL DESCRIPTION

The Trelleborg Sealing Solutions Type TRK are specially designed radial oil seals reinforced with a metal insert but without a spring energized sealing lip and a wavy rubber covered outer diameter. STEFA CD type are available with flat rubber covered outer diameters. These types are not recommended for use in heavily polluted environments.

ADVANTAGES

- Good static sealing and thermal expansion compensation
- Low friction and low heat generation
- Extremely compact design
- Low radial force provides a low break-out torque
- Suitable for scraper applications

APPLICATION EXAMPLES

- Roller bearings
- Tooling fixtures (e.g. drilling machines)
- Sealing against viscous media (e.g. grease)
- Supplementary excluders (shaft ends)
- Axle King Pin seals

OPERATING CONDITIONS

Pressure:	Without pressure
Temperature:	-40 °C to +200 °C (depending on material)
Speed:	Up to 10 m/s
Media:	Mineral and synthetic base greases

Trelleborg Sealing Solutions has carried out several thousands compatibility tests. Please ask your local Trelleborg Sealing Solutions marketing company for details.

IMPORTANT NOTE

The above data are maximum values and cannot be used at the same time, e. g. the maximum operating speed depends on material type, pressure and temperature.

**Table 28: Materials**

TSS Compound Reference	Standard Compound	Temperature °C	Standard Metal insert	Standard spring
N7LMR	NBR (70 Shore A)	-30 °C - 100 °C	Carbon steel	Carbon steel
VCBMR	FKM (70 Shore A)	-20 °C - 200 °C	Carbon steel	Stainless steel

Special grades and other materials (ACM, EACM, EPDM, HNBR, VMQ) on request.
Metal insert and spring, can be supplied in different materials on request.

ORDERING EXAMPLE OIL SEAL TSS TYPE

TSS Type:	K	
Code:	TRKD	
Dimensions:	Shaft diameter	17 mm
	Housing diameter	23 mm
	Width	3 mm
Material:	NBR	
Material Code:	N7LMR	

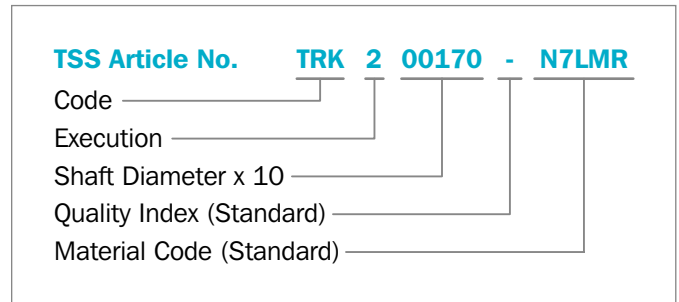
**Table 29: Preferred Series / Dimension, TSS Part Numbers**

Dimension			TSS Part No.	Material	
d ₁	d ₂	b		NBR	FKM
4	8	2	TRK000040	●	●
4	9	2	TRK100040	●	
5	9	2	TRK000050	●	●
5	10	2	TRK100050	●	●
6	10	2	TRK000060	●	●
6	15	3	TRK400060	●	
6	15	4	TRK200060	●	●
6	19	4	TRK300060	●	
7	11	2	TRK000070	●	
8	12	3	TRK000080	●	
8	15	3	TRK200080	●	
9	13	3	TRK000090	●	●
9	16	3	TRK200090	●	
10	12	2	TRK100060	●	
10	14	3	TRK000100	●	●
10	17	3	TRK100100	●	●
10	19	3	TRK200100	●	
10	26	4	TRK400100	●	
11	15	3	TRK000110	●	
12	16	3	TRK000120	●	●
12	18	3	TRK100120	●	●
12	19	3	TRK200120	●	●
13	19	3	TRK000130	●	
14	20	3	TRK000140	●	●

Dimension			TSS Part No.	Material	
d ₁	d ₂	b		NBR	FKM
14	21	3	TRK100140	●	
15	21	3	TRK000150	●	●
15	23	3	TRK100150	●	●
16	22	3	TRK000160	●	●
16	22	4	TRK100160		●
16	24	3	TRK200160	●	
16	25	3	TRK300160		●
17	23	3	TRK000170	●	●
17	23.5	3.4	TRK200170	●	
17	25	3	TRK100170	●	
18	24	3	TRK000180	●	
19	26	4	TRK100190	●	
19	27	4	TRK000190	●	
20	26	3	TRK000200	●	●
20	26	4	TRK100200	●	
20	28	4	TRK200200	●	●
20	48	4	TRK300200	●	
22	28	4	TRK000220	●	●
24	32	4	TRK000240	●	
25	32	4	TRK000250	●	●
25	33	4	TRK100250	●	●
25	35	4	TRK200250	●	●

● In one of the preferred materials
○ In other commercial materials



Dimension			TSS Part No.	Material	
d ₁	d ₂	b		NBR	FKM
26	34	4	TRK000260	●	●
28	35	4	TRK000280	●	
28	35	5	TRK400280	●	
28	37	4	TRK100280		●
30	37	4	TRK000300	●	●
30	40	4	TRK100300	●	●
32	42	4	TRK000320	●	●
33	40	3	TRK100330	●	
35	41	4	TRK000350	●	●
35	42	2	TRK300350	●	
35	42	4	TRK100350	●	
35	45	4	TRK200350	●	
38	48	4	TRK000380	●	
40	47	4	TRK000400	●	
40	48	4	TRK100400		
40	50	4	TRK200400	●	●
42	49	3	TRK100420		●
42	52	4	TRK000420	●	
45	52	4	TRK000450	●	
45	55	4	TRK100450	●	
45	62	8	TRKB00450	●	
48	58	4	TRK000480	●	
50	58	4	TRK000500	●	●
50	60	6	TRK100500	●	
50	62	5	TRK200500	●	
55	63	5	TRK000550	●	●
55	73	8.5	TRK100550	●	
60	68	4	TRK200600		●
60	72	3	TRK100600	●	
60	72	4	TRK000600	●	
70	78	5	TRK000700	●	●
70	81,5	6	TRK100700	●	
74	83	6	TRK100740	●	
74	83	11	TRK000740	●	
75	95	7	TRK000750	●	
120	130	7	TRK001200	●	

- In one of the preferred materials
- In other commercial materials



■ Type TRG – Medium Grease

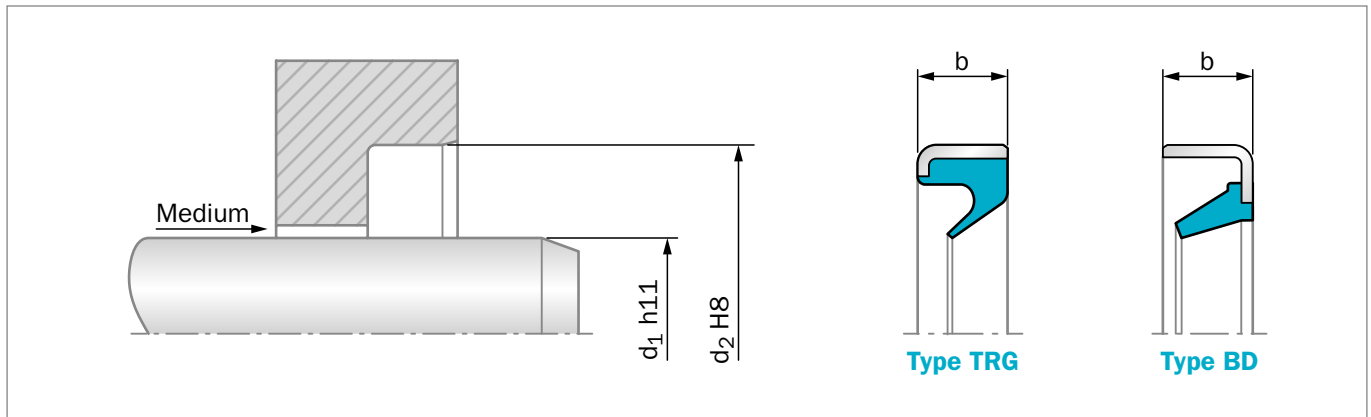

Figure 30: Installation Drawing

GENERAL DESCRIPTION

The Trelleborg Sealing Solutions Type TRG and STEFA Type BD are special metal cased radial oil seals without spring energized sealing lips. These types are not recommended for use in heavily polluted environments. As the static sealing between housing and metallic shell is limited, low viscosity media can "creep". Better performance can be achieved with Epoxy based resin outer diameter coatings. This special treatment is on request.

ADVANTAGES

- Good radial stiffness
- Good fitting stability avoiding pop-out of the seal
- Low friction and low heat generation
- Extremely compact design
- Low radial force provides a low break-out torque
- Suitable for scraper applications

APPLICATION EXAMPLES

- Roller bearings
- Tooling fixtures (e.g. drilling machines)
- Sealing against viscous media (e.g. grease)
- Supplementary excluders (shaft ends)
- Axle King Pin seals

OPERATING CONDITIONS

Pressure:	Without pressure
Temperature:	-40 °C to +200 °C (depending on material)
Speed:	Up to 10 m/s
Media:	Mineral and synthetic base greases

Trelleborg Sealing Solutions has carried out several thousands compatibility tests. Please ask your local Trelleborg Sealing Solutions marketing company for details.

IMPORTANT NOTE

The above data are maximum values and cannot be used at the same time, e. g. the maximum operating speed depends on material type, pressure and temperature.



Table 30: Materials

TSS Compound Reference	Standard Compound	Temperature °C	Standard Metal insert	Standard spring
N7MLR	NBR (70 Shore A)	-30 °C - 100 °C	Carbon steel	Carbon steel
4N01	NBR (75 Shore A)	-30 °C - 100 °C	Carbon steel	Carbon steel
VCBMR	FKM (70 Shore A)	-20 °C - 200 °C	Carbon steel	Stainless steel
4V01	FKM (75 Shore A)	-20 °C - 200 °C	Carbon steel	Stainless steel

Special grades and other materials (ACM, EACM, EPDM, HNBR, VMQ) on request.
 Metal insert and spring, can be supplied in different materials on request.

ORDERING EXAMPLE OIL SEAL TSS TYPE

TSS Type:	G	
Code:	TRG	
Dimensions:	Shaft diameter	70 mm
	Housing diameter	78 mm
	Width	5 mm
Material:	NBR	
Material Code:	N7LMR	

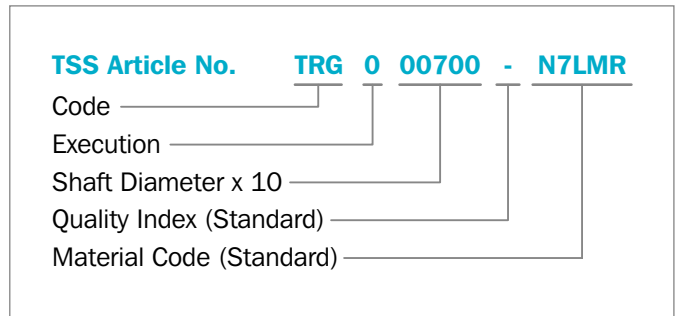



Table 31: Preferred Series / Dimension, TSS Part Numbers

Dimension			TSS Part No.	Material	
d ₁	d ₂	b		NBR	FKM
3	8	2	TRG000030	●	
3	10	6	TRG100030		●
4	8	2	TRG000040		●
5	9	2	TRG000050	●	
6	10	2	TRG000060	●	●
6	12	2	TRG100060	●	
7	11	2	TRG000070	●	●
8	14	2	TRG100080	●	
8	15	3	TRG200080	●	
12	16	3	TRG000120	●	●
13	19	3	TRG000130	●	
14	22	3	TRG200140	●	
15	21	3	TRG000150	●	
15	23	3	TRG100150		●
16	20	2,5	TRG000160	●	
16	24	3	TRG200160	●	
16	24	4	TRG100160		●
16	25	3	TRG300160	●	
17	23	3	TRG000170	●	
18	24	3	TRG000180	●	●
19	26	2	TRG400190	●	
20	24	2,5	TRG300200	●	
20	26	3	TRG100200	●	●
20	26	4	TRG100200	●	
20	28	4	TRG200200	●	●
22	28	4	TRG000220	●	
24	32	4	TRG000240	●	
25	32	4	TRG000250	●	●
25	33	4	TRG100250	●	
25	35	4	TRG200250	●	
27	35	2	TRG000270	●	
28	37	4	TRG100280	●	
30	37	4	TRG000300	●	
30	40	4	TRG100300	●	
32	42	4	TRG000320	●	
35	42	2	TRG200350	●	
35	42	4	TRG100350	●	●
35	72	4	TRG400350	●	
38	48	4	TRG000380	●	
38.1	48	2	TRG000381	●	
40	47	4	TRG000400	●	
40	50	4	TRG200400	●	

Dimension			TSS Part No.	Material	
d ₁	d ₂	b		NBR	FKM
40	52	5	TRG300400	●	
43	53	4	TRG000430	●	
45	52	4	TRG000450	●	
45	52	3	TRG200450	●	
45	55	4	TRG100450	●	●
50	58	4	TRG000500	●	
55	63	5	TRG000550	●	●
60	72	3	TRG000600		
67	75.5	4.3	TRG000670	●	
77	85.5	4.8	TRG000770	●	

● In one of the preferred materials
○ In other commercial materials



Turbo Seals with Hydrodynamic Sealing Aids

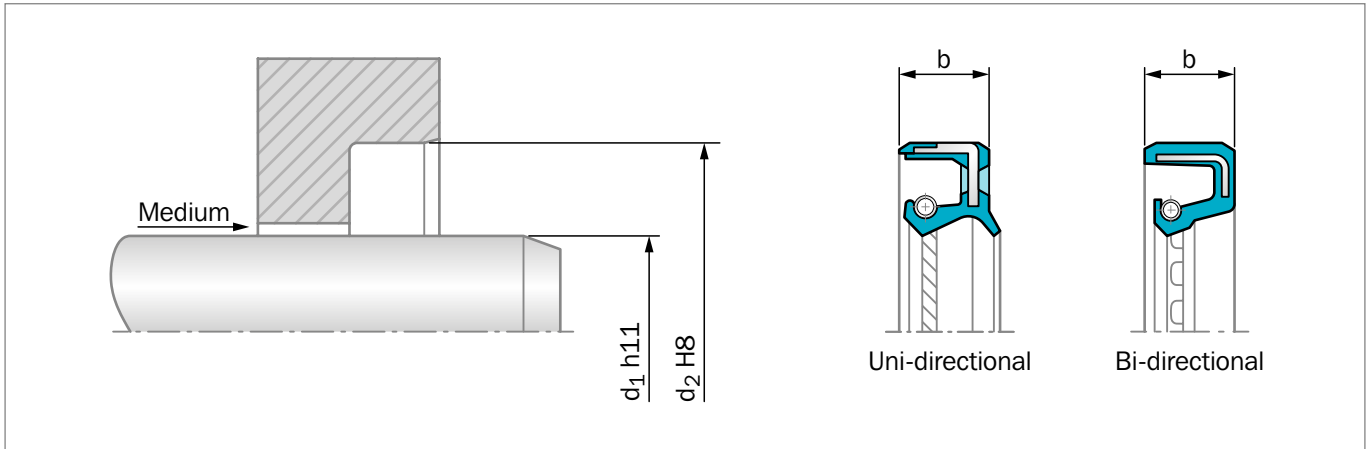

Figure 31: Installation Drawing

GENERAL DESCRIPTION

Trelleborg Sealing Solutions Turbo Seals are a range of seals, the lips of which are provided with ribs or other geometric figures in a variety of shapes.

Optimum conditions are attained when a thin film of lubricant is formed so the lip does not come in contact with the shaft. Such conditions are created by the Turbo Seals.

The hydrodynamic sealing aids support the sealing function by increasing shaft speed.

The frictional loss of the Turbo Seals is significantly lower than that caused by conventional radial seals without hydrodynamic sealing aids.

The pumping effect starts at relatively low shaft speed. The pumping effect is understood as the capacity of the seal to the medium side. In order to avoid leakage at low speed or at standstill, Turbo Seals include a static sealing edge which provides a continuous contact line against the shaft.

FRICITION

The use of certain materials on the sealing element is limited primarily by the heat generated by friction, superimposed on the ambient temperature.

Owing to the enhanced formation of a lubrication film, Turbo Seals can be used for appreciably higher peripheral speeds than conventional seals made of the same material. The diagram in Figure 32 shows the frictional losses of conventional seals, single-acting and bi-directional Turbo Seals, as determined during comparative laboratory tests.

It will be noted that the frictional loss caused by a conventional

seal at a peripheral speed of 10 m/s is incurred by a Turbo Seal only when the peripheral speed has reached 16 m/s.

OPERATING CONDITIONS

Speed:	Up to 20 m/s (depending on material)
Media:	Mineral and synthetic lubricants (CLP, HLP, APGL etc.)

Trelleborg Sealing Solutions has carried out several thousands compatibility tests. Please ask your local Trelleborg Sealing Solutions marketing company details.

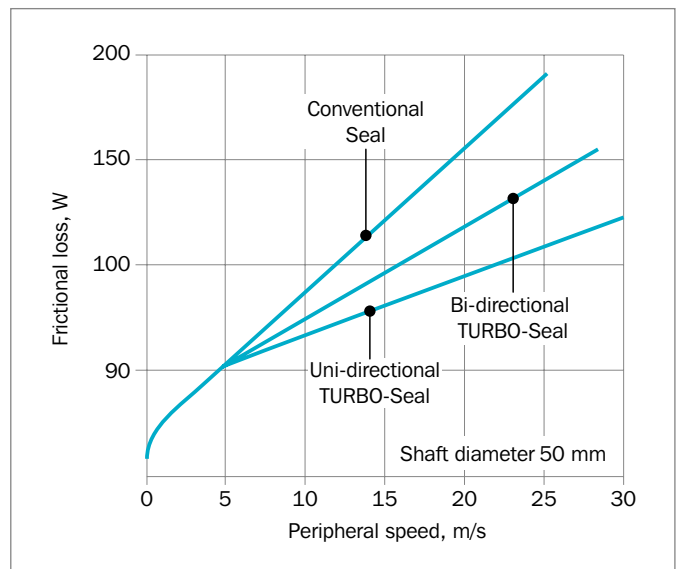

Figure 32: Friction loss

**Table 32: Materials**

TSS Compound Reference	Standard Compound	Temperature °C	Standard Metal insert	Standard spring
N7MMR	NBR (70 Shore A)	-30 °C - 100 °C	Carbon steel	Carbon steel
4N011/4NV11	NBR (75 Shore A)	-30 °C - 100 °C	Carbon steel	Carbon steel
VCBVR	FKM (70 Shore A)	-20 °C - 200 °C	Carbon steel	Stainless steel
4V012	FKM (75 Shore A)	-20 °C - 200 °C	Carbon steel	Stainless steel

Special grades and other materials (ACM, EACM, EPDM, HNBR, VMQ) on request.
 Metal insert, and spring as, can be supplied in different materials on request.

For more details please contact your local Trelleborg Sealing Solutions marketing company.



■ Rotary and Axial Seal Combination

GENERAL DESCRIPTION

In many applications, rotary shaft lip seals are used to seal against various media.

Lip seals often fail because of the destruction of the lubricant film, resulting in rapid wear, due to the ingress of dirt, dust and moisture. The use of shaft seals with one or more auxiliary sealing lips (dust lips) provides a limited improvement, but it is not always sufficient. In order to meet the constantly increasing sealing requirements, especially for the environmental protection and long service life, the Trelleborg Sealing Solutions COMBI-seal is a simple solution. It has proved to be particularly well suited even in critical applications with heavy contamination. The COMBI-seal consists of a GAMMA seal and a rotary shaft lip seal working together. The lip seal provides the counterface for the GAMMA seal which is fixed to the shaft by press fit (see Figure 33 and Figure 34).

Years of successful experiences show that another frequently used alternative consists of a V-Ring seal with a standard seal selected inside the type list: TRC, TRD, TRB, TRF.

The rotary shaft seal should be ordered **"Without Markings"** on the air side.

RADIAL OIL SEAL + GAMMA SEAL

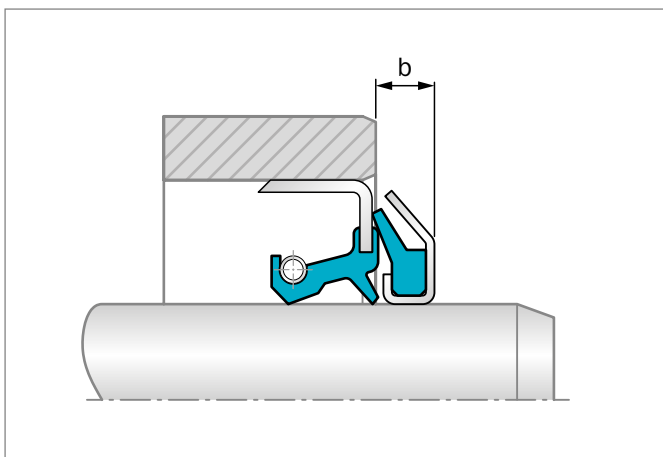

Figure 33: GAMMA seal fitted on the shaft end

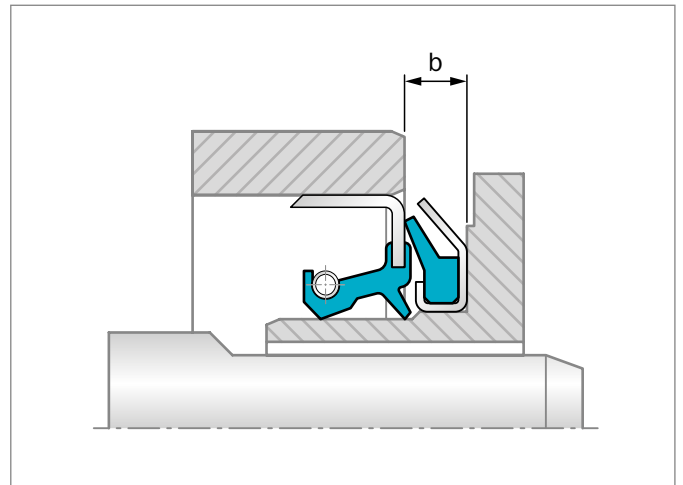

Figure 34: GAMMA seal fitted on the shaft boss

RADIAL OIL SEAL + V-RING

The function of the rotary axial seal is to prevent by centrifugation the intrusion of particles and water drops.

In other words, it adds its original protection capacity to the radial seal functionality. Sufficient space is required on the shaft to host the axial seal width (see Figure 35).

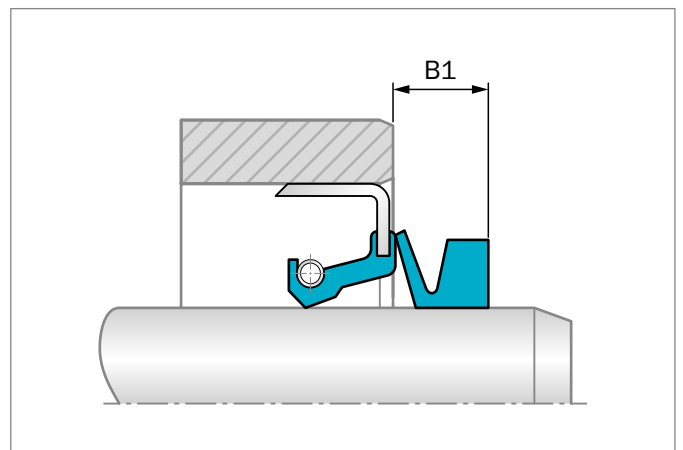

Figure 35: V-Ring fitted on the shaft end

HOUSING AND SHAFT DESIGN

The radial lip seal needs to be assembled in the housing according to usual fitting instructions. Both the V-Ring and GAMMA seal are assembled later on the shaft. The shaft design requires adaptation by an elongation corresponding at least to B1 (b) dimensions. In case of very high peripheral speeds, the V-Ring body should be radially supported. See also the instructions in the specific catalog chapter for more information.



PRODUCT DESCRIPTION

The combination of Radial shaft seal with V-Ring or GAMMA seals is recommended for use in heavily polluted environments.

Both the radial shaft seal and the GAMMA seal housing may also be manufactured with a different metal shell, as well as different rubber types for sealing elements. See specific paragraphs.

ADVANTAGES

- Longer service life and high function reliability
- Good IP protection for electrical motors (VDE-Norm 0470-1)
- Good protection against water splash and welding sparks
- Simple handling
- Superior total economy
- Friction loss decreases with increasing shaft speed

APPLICATION EXAMPLES

Typical applications are all equipment working in contaminated environments where dust, foreign matter and liquid splatter are present.

Some examples:

- gear motors
- journal and gear transmissions
- bearing housings
- power saws
- utility vehicles
- agricultural machinery and equipment
- wheel hubs
- propeller shafts
- pumps
- hydraulic motors
- tool machinery
- equipment for steel manufacturing
- metal working machinery

OPERATING CONDITIONS

Pressure:	See radial seal data
Temperature:	-40 °C to +200 °C (depending on material)
Speed:	Up to 10 m/s (depending on material)
Media:	Mineral and synthetic oils (CLP, HLP, APGL etc.)

Trelleborg Sealing Solutions has carried out several thousands compatibility tests. Please ask your local Trelleborg Sealing Solutions marketing company for details.

IMPORTANT NOTE

The above data are maximum values and cannot be used at the same time, e. g. the maximum operating speed depends on material type, pressure and temperature.

MATERIALS

See specific chapters.

ORDERING EXAMPLE

Order components separately as per specific chapters. Order the radial oil seals "**without marking**".



■ Type TRJ/TRL

FIBER REINFORCED OIL SEALS FOR LARGE DIAMETER

Fiber reinforced oil seals contain no metal parts with the exception of the spring. Instead of the metal insert, a reinforced fiber component is molded into the body of the seal. Damage through transport and mounting is consequently excluded.

Fiber reinforced oil seals are mainly used for installation in constructions and equipment with large diameters. The use of an axial retaining plate is necessary except for the type TRJ/F and respectively for the type TRL/F.

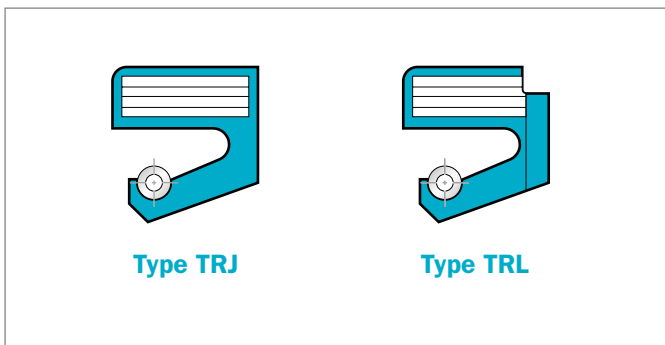

Figure 36: Fiber reinforced design for large diameters

SPLIT VERSION

To ease the mounting, or in case of repair, the types TRJ and TRL are also available in split versions.

To ensure effective sealing at the split ends, a full rubber section is molded at the join so that contact between homogeneous elastic surfaces maximizes the sealing effect. The interface should always be above the oil level.

If two seals in split versions are mounted together, the interface should be turned a minimum of 30° to the side.

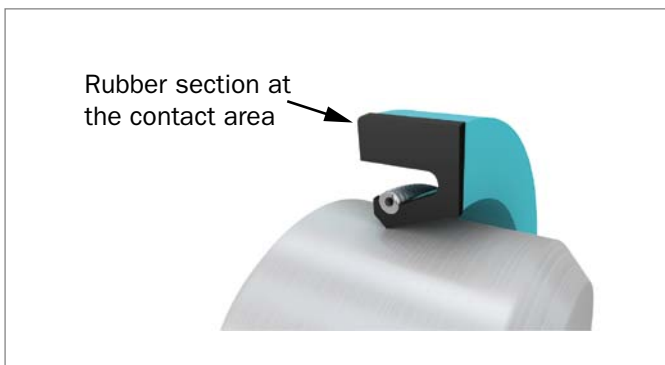

Figure 37: Contact area, split seal

SEPARATION OF TWO MEDIA WITH TYPE TRL

A single oil seal should not be used for the separation of two media. In such cases, two seals are fitted in a back to back arrangement. The type TRL is suitable for the sealing of large diameters. It is a special design with peripheral and radial grooves where a lubricant could be applied.

The peripheral groove on the seal reduces the need to cut a groove in the housing (see Figure 38).

The seal can be used for:

- Isolation of two media
- If lubrication is necessary from the outside

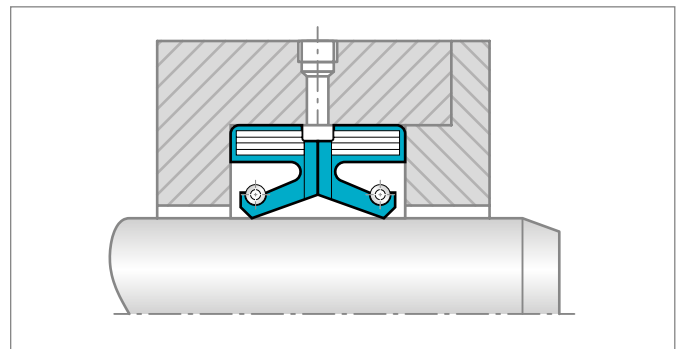

Figure 38: Type TRL mounted back to back

SPECIAL DESIGN TRJ/F AND TRL/F WITH REINFORCED SHOULDER

Whenever a retaining plate cannot be fitted we can supply a seal made in a special hardened compound, namely type TRJ/F and TRL/F, which makes the seal self-retaining and providing effective sealing at the O.D.

Trelleborg Sealing Solutions type TRJ/F and TRL/F are supplied in standard form and are not available in split versions (see Figure 39).

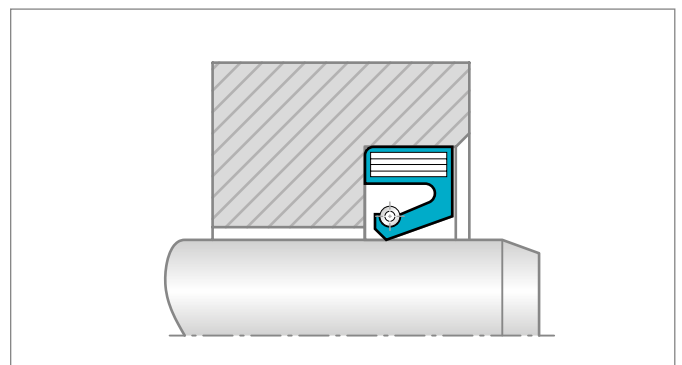

Figure 39: Type TRJ/F mounted without axial retaining plate



DESIGN INSTRUCTIONS

Installation on the shaft

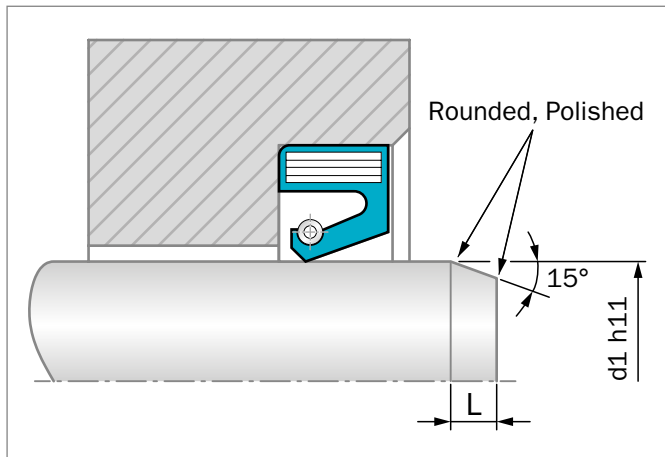

Figure 40: Installation of the oil seal

To facilitate the installation of the seal with minimum risk of lip damage, the shaft require a 15° chamfer with length "L" as the function of its diameter "d1".

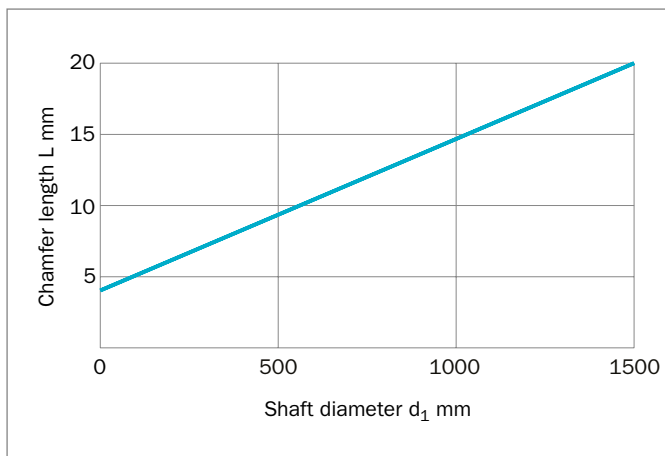

Figure 41: Chamfer length as a function of the shaft diameter

Eccentricity

Eccentricity between the shaft and housing bore centers should be avoided in order to eliminate unilateral load of the lip.

Table 33: Static Eccentricity

d1	b x f (mm)	max. stat. Ecc. (mm)
100 - 250	16 x 20	0.50
250 - 400	20 x 22	0.55
400 - 600	22 x 25	0.62
> 600	25 x 32	0.70

Shaft run out

Shaft run out should be avoided or kept to a minimum. At higher speeds there is a risk that the inertia of the sealing lip prevents it from following the shaft movement. The seal must be located next to the bearing and the bearing play be maintained at the minimum value possible.

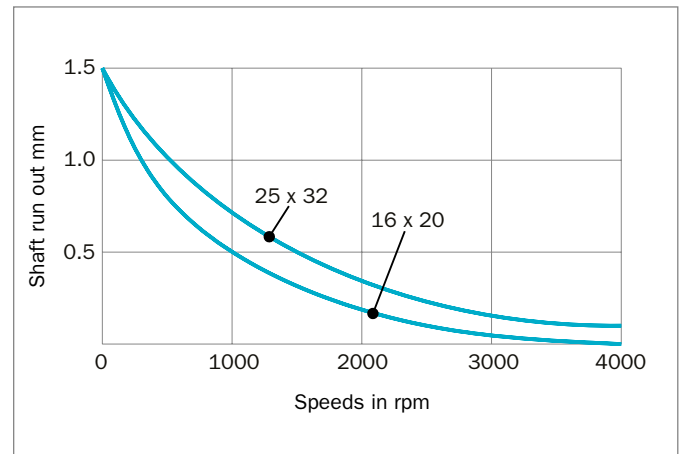

Figure 42: Shaft run out

Installation in the gland

The static seal in the mounting bore is provided by the corresponding force fit allowance at the outer sheath of the seal.

The bore tolerance is specified to DIN ISO 286T2-H8.

Values for the surface roughness in the gland are specified in ISO 6194/1.

General values:	R_a	=	1.6 - 3.2 μm
	R_z	=	6.3 - 12.5 μm

For gas sealing, a good score-free and spiral-free surface finish is necessary. If the rotary shaft lip seal is bonded into the housing, ensure that no adhesive comes into contact with the sealing lip or the shaft.

The bore d_2 of the sealing housing indicated in Table 33 as a function of shaft diameter. ($d_2 = d_1 + 2 \times f$), see page 99.

The width (b) including the tolerance is also given in Table 34.



INSTALLATION, TYPE TRJ

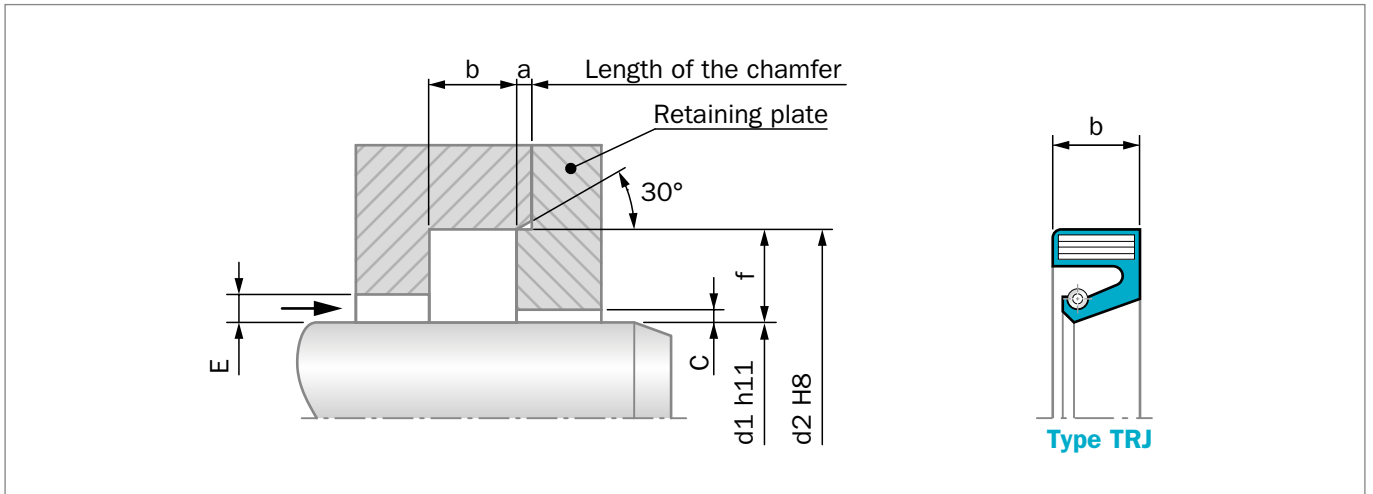

Figure 43: Installation Drawing

INSTALLATION, TYPE TRL

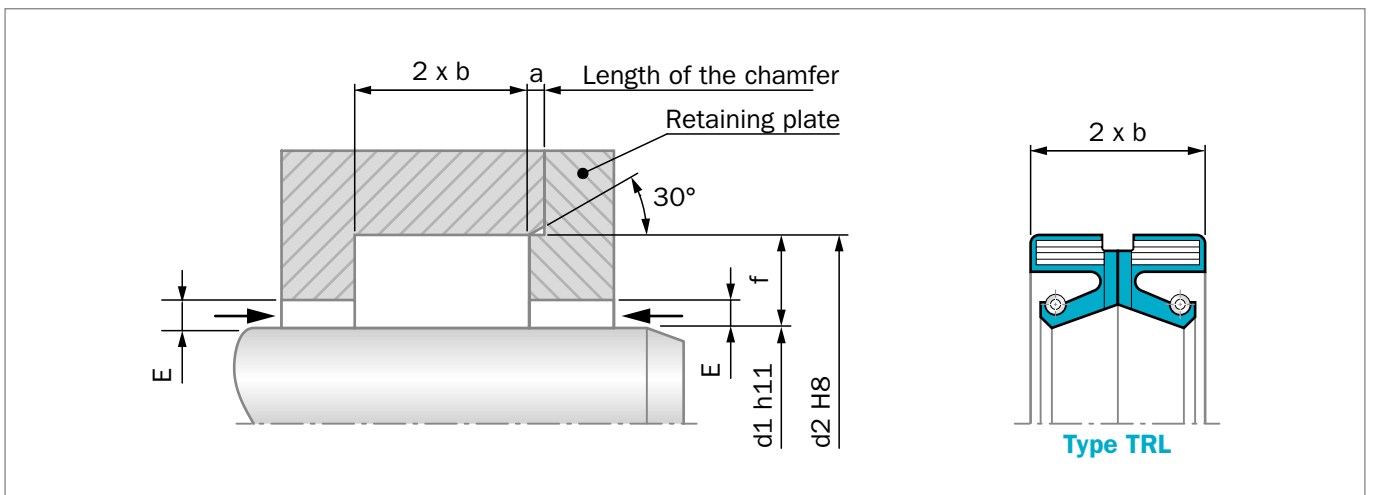

Figure 44: Installation Drawing

Table 34: Dimensions

d1	b x f	a	E	C	b
100 - 250	16 x 20	2.0	9	4	16 ±0.1
250 - 400	20 x 22	2.2	11	6	20 ±0.2
400 - 600	22 x 25	2.5	11	7	22 ±0.2
> 600	25 x 32	3.2	14	8	25 ±0.2



OPERATING CONDITIONS, TYPE TRJ AND TRL

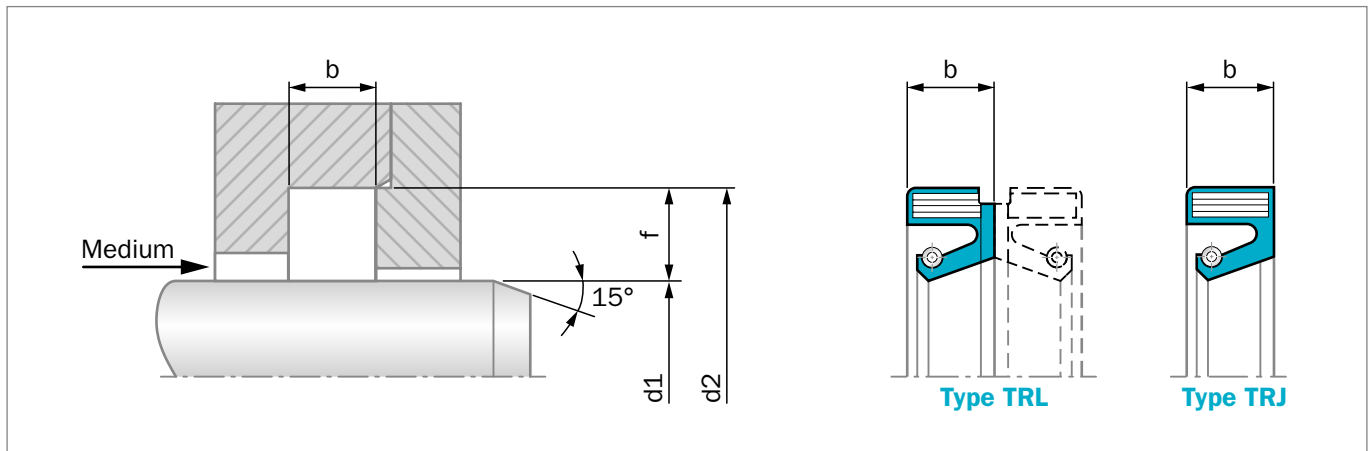

Figure 45: Installation Drawing

Table 35: Material

Standard-Material*	TSS Material Code	Standard Spring
NBR (75 Shore A)	4NC01	Carbon steel
HNBR (75 Shore A)	4HC01	Carbon steel
FKM (75 Shore A)	4VC02	Stainless steel

* The spring can be supplied in different materials on request.

Table 36: Operating Conditions

Type	Temperature	Speed	Pressure	Dimensions
TRJ	-30 °C to +200 °C	up to 25 m/s	0.05 MPa	100 - 1890
TRL	-30 °C to +200 °C	up to 25 m/s	0.05 MPa	100 - 1890

ORDERING EXAMPLE

TSS Type:	J	
Code:	TRJ	
Dimensions:	Shaft diameter	100 mm
	Housing diameter	125 mm
	Width	12.5 mm
Material:	NBR	
Material Code:	4NC01	

TSS Article No. **TRJ 001000 - 4NC01**

TSS Code —————

Shaft Diameter x 10 —————

Quality Index (Standard) —————

Material —————



Table 37: Preferred Series / Dimension, TSS Part Numbers

Dimension			TSS Part No.	Material		Dimension			TSS Part No.	Material	
d ₁	d ₂	b		NBR	FKM	d ₁	d ₂	b		NBR	FKM
100	125	12.5	TRJ001000	●		405	445	20	TRJ004050	●	
115	140	15	TRJ001150		●	430	474	20	TRL004300	●	●
120	150	13	TRJ001200	●		440	490	22	TRJ004400	●	●
125	160	12	TRJ001250	●		445	495	22	TRJ004450	●	
130	170	16	TRJ001300	●		450	500	22	TRJ004500	●	
133	165	12.5	TRL001330	●		460	504	20	TRL004600	●	
145	175	15	TRJ001450	●		470	520	25	TRJ004700	●	
150	180	13	TRJ001500	●	●	480	530	22	TRJ004800	●	●
170	200	15	TRJ001700	●		480	530	22	TRL004800	●	
175	215	16	TRL001750	●		490	534	20	TRL004900	●	
180	218.1	15.9	TRJ001800	●		500	544	22	TRJ005000	●	
190	220	16	TRJ001900	●		530	580	22	TRJ005300	●	
200	230	14	TRL002000	●		540	590	22	TRJ005400	●	
200	240	16	TRJ002000	●		540	590	22	TRL005400	●	●
220	260	16	TRJ002200	●		560	610	22	TRJ005600	●	
220	270	16	TRJ202200	●		570	620	22	TRL005700	●	●
230	260	15.7	TRJ002300	●		596	660	32	TRL005960	●	
240	270	15	TRJ002400	●		600	650	22	TRJ006000	●	
240	280	16	TRJ302400	●		625	670	20	TRJ006250	●	
250	280	16	TRL002500	●		630	680	22	TRL006300	●	●
250	290	16	TRJ102500		●	640	690	22	TRJ006400	●	
260	290	16	TRJ002600	●		650	700	22	TRJ006500	●	
260	300	14	TRL002600	●		650	714	25	TRL006500	●	
260	304	20	TRJ102600	●	●	660	704	20	TRJ106600	●	
270	310	18	TRL002700	●		680	730	20	TRJ006800	●	
270	310	20	TRJ002700	●	●	696	760	32	TRL006960	●	
280	320	16	TRJ102800	●		700	750	25	TRL007000	●	
280	324	20	TRJ202800	●		710	760	24.5	TRL107100	●	
290	334	20	TRJ002900	●		710	760	25.5	TRL007100	●	
300	340	18	TRL003000	●		730	794	25	TRJ007300	●	
310	340	14.5	TRJ103100	●		735	799	25	TRJ007350		●
310	350	20	TRJ003100	●		750	810	25	TRL107500	●	
315	355	16	TRJ003150		●	750	814	25	TRL007500	●	
320	360	18	TRJ003200	●		762	810	20	TRL007620	●	
320	364	20	TRJ103200	●		766	830	32	TRL007660	●	
330	370	20	TRJ003300	●		775	839	25	TRL007750	●	
350	394	20	TRL003500	●		790	854	25	TRL007900	●	
370	410	18	TRL003700	●		820	870	22	TRL008200	●	
380	420	18	TRL003800	●		860	900	18	TRJ008600	●	
380	420	20	TRJ003800	●		860	924	25	TRL008600	●	
390	434	20	TRJ003900	●		880	944	25	TRL008800	●	●
400	440	18	TRL004000	●		970	1,034	25	TRJ009700		●
400	444	20	TRJ104000	●		1,100	1,164	25	TRLOX1100	●	●

**Table 38: Further dimensions for Type TRJ/TRL**

Dimensions				Type		Dimensions				Type	
d ₁	d ₂	b	f	TRJ	TRL	d ₁	d ₂	b	f	TRJ	TRL
100.0	115.0	8.9	7.5	●		120.0	140.0	13.0	10.0	●	
100.0	115.0	9.0	7.5			120.0	144.0	14.5	10.0	●	
100.0	120.0	13.0	10.0	●		120.0	144.0	15.5	12.0	●	
100.0	125.0	13.0	12.5	●		120.0	145.0	15.5	12.5	●	
100.0	125.0	15.0	12.5	●		120.0	150.0	13.0	15.0	●	
100.0	125.4	12.7	12.7	●	●	120.0	150.0	15.0	15.0	●	
100.0	130.0	12.0	15.0	●		120.0	150.0	16.0	15.0	●	
100.0	130.0	15.0	15.0	●		120.0	152.0	16.0	16.0	●	
100.0	132.0	12.5	16.0	●	●	120.0	160.0	12.0	20.0	●	
100.0	140.0	16.0	20.0	●		120.0	160.0	16.0	20.0	●	
105.0	129.0	13.0	12.0	●		120.0	170.0	15.0	25.0	●	
105.0	130.0	12.0	12.5	●		125.0	140.0	10.0	7.5	●	
105.0	130.0	13.0	12.5	●		125.0	150.0	12.0	12.5	●	
105.0	133.5	12.7	14.3	●		125.0	150.0	15.0	12.5	●	
105.0	137.0	16.0	16.0	●		125.0	153.5	12.7	14.2	●	
105.0	140.0	12.0	17.5	●		125.0	155.0	12.0	15.0	●	
105.0	143.0	16.0	19.0	●		125.0	160.0	12.0	17.5	●	
105.0	145.0	16.0	20.0	●		125.0	160.0	13.0	17.5	●	
110.0	126.0	9.0	8.0	●		125.0	160.0	15.0	17.5	●	
110.0	126.0	12.0	8.0	●		125.0	165.0	15.0	20.0	●	
110.0	130.0	9.0	10.0	●		125.0	165.0	16.0	20.0	●	
110.0	130.0	12.0	10.0	●		127.0	157.0	15.0	15.0	●	
110.0	130.0	13.0	10.0	●		128.0	165.0	15.0	18.5	●	
110.0	135.0	12.0	12.5	●		130.0	150.0	10.0	10.0	●	
110.0	140.0	12.0	15.0	●		130.0	150.0	12.0	10.0	●	
110.0	140.0	14.0	15.0	●		130.0	155.0	10.0	12.5	●	
110.0	140.0	15.0	15.0	●		130.0	155.0	15.5	12.5	●	
110.0	140.0	16.0	15.0	●		130.0	160.0	12.0	15.0	●	
110.0	141.0	13.7	15.5	●		130.0	160.0	15.0	15.0	●	
110.0	145.0	19.0	17.5	●		130.0	160.0	16.0	15.0	●	
110.0	150.0	16.0	20.0	●		130.0	165.0	13.0	17.5	●	
115.0	137.0	8.8	11.0	●		130.0	170.0	13.0	20.0	●	
115.0	137.0	9.0	11.0		●	130.0	170.0	16.0	20.0	●	
115.0	140.0	12.0	12.5	●		133.0	165.0	12.5	16.0		●
115.0	140.0	13.0	12.5	●	●	134.0	169.0	15.0	17.5	●	
115.0	140.4	9.5	12.7	●		135.0	157.0	8.0	11.0	●	
115.0	145.0	12.0	15.0	●		135.0	160.0	12.0	12.5	●	
115.0	145.0	15.0	15.0	●		135.0	165.0	13.0	15.0	●	
115.0	150.0	15.0	17.5	●		135.0	167.0	15.0	16.0	●	
115.0	155.0	16.0	20.0	●		135.0	160.0	12.0	12.5	●	
118.0	140.0	14.0	11.0	●							
120.0	140.0	12.5	10.0	●							

These additional dimensions available on request.
Please contact Trelleborg sealing solutions.



Dimensions				Type	
d ₁	d ₂	b	f	TRJ	TRL
135.0	165.0	13.0	15.0	●	
135.0	167.0	15.0	16.0	●	
135.0	160.0	12.0	12.5	●	
135.0	165.0	13.0	15.0	●	
135.0	167.0	15.0	16.0	●	
135.0	170.0	12.0	17.5	●	
135.0	170.0	13.0	17.5	●	
135.0	170.0	16.5	17.5	●	
135.0	175.0	16.0	20.0	●	
136.0	160.0	10.0	12.0	●	
138.0	180.0	15.0	21.0	●	
139.0	155.0	10.0	8.0	●	
139.0	169.0	14.6	15.0	●	
140.0	155.0	10.0	7.5	●	
140.0	160.0	13.0	10.0	●	
140.0	165.0	15.0	12.5	●	
140.0	168.0	21.0	14.0	●	
140.0	170.0	15.0	15.0	●	
140.0	180.0	12.0	20.0	●	
140.0	180.0	15.0	20.0	●	
140.0	180.0	16.0	20.0	●	●
140.0	190.0	15.0	25.0	●	
143.0	165.0	10.0	11.0	●	
144.0	180.0	15.0	18.0	●	
145.0	170.0	13.0	12.5	●	
145.0	170.0	15.0	12.5	●	
145.0	180.0	12.0	17.5	●	
145.0	180.0	14.0	17.5	●	
149.0	179.0	13.0	15.0	●	
149.0	180.0	16.0	15.5	●	
150.0	172.0	12.7	11.0	●	
150.0	180.0	12.0	15.0	●	●
150.0	180.0	13.0	15.0	●	
150.0	180.0	14.0	15.0	●	
150.0	180.0	15.0	15.0	●	
150.0	185.0	15.0	17.5	●	
150.0	188.0	16.0	19.0	●	
150.0	190.0	16.0	20.0	●	●
150.0	190.0	20.0	20.0	●	
152.0	180.0	14.0	14.0	●	
152.0	190.0	19.0	19.0	●	
154.0	180.0	12.2	13.0	●	
155.0	175.0	10.8	10.0	●	
155.0	180.0	12.5	12.5	●	

Dimensions				Type	
d ₁	d ₂	b	f	TRJ	TRL
155.0	180.0	15.0	12.5	●	
155.0	190.0	13.0	17.5	●	
156.0	195.0	15.0	19.5		●
159.0	200.0	16.0	20.5	●	
160.0	188.0	21.0	14.0	●	
160.0	190.0	15.0	15.0	●	
160.0	190.0	16.0	15.0	●	
160.0	200.0	16.0	20.0	●	●
165.0	190.0	15.0	12.5	●	
165.0	195.0	15.0	15.0	●	●
165.0	200.0	15.0	17.5	●	
165.0	203.0	19.0	19.0	●	
165.0	205.0	16.0	20.0	●	
168.0	200.0	16.0	16.0	●	
169.0	200.0	12.0	15.5	●	
169.0	201.0	12.5	16.0	●	
170.0	192.0	10.7	11.0	●	
170.0	195.0	14.2	12.5	●	
170.0	200.0	12.0	15.0	●	●
170.0	200.0	15.0	15.0	●	
170.0	205.0	18.0	17.5	●	
170.0	210.0	16.0	20.0	●	●
170.0	220.0	15.0	25.0	●	
170.0	223.0	20.0	26.5	●	
174.0	214.0	16.0	20.0	●	
175.0	200.0	15.0	12.7	●	
175.0	205.0	15.0	15.0	●	●
175.0	215.0	15.0	20.0	●	
175.0	215.0	16.0	20.0	●	
180.0	200.0	15.0	10.0	●	
180.0	205.0	12.5	12.5	●	
180.0	210.0	12.0	15.0	●	
180.0	210.0	15.0	15.0	●	●
180.0	212.0	16.0	16.0	●	
180.0	215.0	15.0	17.5	●	
180.0	216.0	21.8	18.0	●	
180.0	220.0	13.0	20.0	●	
180.0	220.0	16.0	20.0	●	●
180.0	230.0	16.0	25.0	●	
182.0	215.0	16.0	16.5	●	
185.0	210.0	13.0	12.5	●	
185.0	215.0	15.0	15.0		●

These additional dimensions available on request.
Please contact Trelleborg sealing solutions.



Dimensions				Type		Dimensions				Type	
d ₁	d ₂	b	f	TRJ	TRL	d ₁	d ₂	b	f	TRJ	TRL
185.0	215.0	16.0	15.0	●		216.0	241.5	12.7	12.7	●	
185.0	220.0	16.0	17.5	●		216.0	254.0	16.0	19.0	●	
185.0	225.0	16.0	20.0	●	●	216.0	254.0	19.0	19.0	●	
185.0	230.0	16.0	22.5	●		216.9	254.0	19.0	18.5	●	
190.0	210.0	15.0	10.0	●		218.0	245.0	12.5	13.5	●	
190.0	212.0	11.7	11.0	●		218.0	270.0	22.0	26.0	●	
190.0	215.0	16.0	12.5	●		220.0	245.0	12.5	12.5	●	●
190.0	220.0	15.0	15.0	●	●	220.0	250.0	12.0	15.0	●	
190.0	220.0	16.0	15.0	●		220.0	250.0	15.0	15.0	●	●
190.0	225.0	18.0	17.5	●		220.0	250.0	16.0	15.0	●	
190.0	230.0	15.0	20.0	●		220.0	250.0	19.0	15.0	●	
190.0	230.0	16.0	20.0	●	●	220.0	254.0	16.0	17.0	●	
195.0	220.0	15.0	12.5	●		220.0	255.0	16.0	17.5	●	
195.0	230.0	15.0	17.5	●		220.0	255.0	18.0	17.5	●	
195.0	230.0	16.0	17.5	●		220.0	258.0	25.4	19.0	●	
195.0	235.0	16.0	20.0	●		220.0	260.0	15.0	20.0	●	
196.0	228.0	16.0	16.0	●		220.0	260.0	16.0	20.0	●	●
196.0	235.0	19.0	19.5	●		220.0	260.0	20.0	20.0	●	
200.0	225.0	15.0	12.5	●		220.0	260.0	22.0	20.0	●	
200.0	230.0	15.0	15.0	●	●	220.0	270.0	16.0	25.0	●	
200.0	230.0	16.0	15.0	●		225.0	250.0	12.5	12.5	●	
200.0	235.0	18.2	17.5	●		225.0	260.0	16.0	17.5	●	
200.0	240.0	15.0	20.0	●		225.0	270.0	16.0	22.5	●	
200.0	240.0	16.0	20.0	●	●	226.0	258.0	16.0	16.0	●	
200.0	250.0	15.0	25.0	●		228.0	268.0	16.0	20.0		●
200.0	250.0	18.0	25.0	●		228.0	268.0	20.0	20.0	●	
205.0	230.0	16.0	12.5	●		230.0	255.0	10.0	12.5	●	
205.0	245.0	16.0	20.0	●		230.0	255.0	11.7	12.5	●	
205.0	245.0	20.0	20.0	●		230.0	255.0	15.0	12.5	●	
205.0	250.0	16.0	22.5	●		230.0	260.0	12.5	15.0	●	
210.0	240.0	13.0	15.0	●		230.0	260.0	15.0	15.0	●	
210.0	245.0	15.0	17.5	●		230.0	260.0	16.0	15.0	●	
210.0	245.0	18.0	17.5	●		230.0	265.0	18.0	17.5	●	
210.0	246.0	16.0	18.0	●		230.0	270.0	16.0	20.0	●	●
210.0	250.0	15.0	20.0	●		230.0	280.0	15.0	25.0	●	
210.0	250.0	16.0	20.0	●	●	230.0	280.0	23.0	25.0		●
210.0	274.0	26.0	32.0	●		230.0	285.0	23.0	27.5	●	
213.0	248.0	16.0	17.5	●		234.9	273.0	19.0	19.1	●	
215.0	240.0	12.0	12.5	●		235.0	270.0	16.0	17.5	●	
215.0	245.0	16.0	15.0	●	●	235.0	270.0	18.0	17.5	●	
215.0	247.0	12.5	16.0	●		235.0	275.0	20.0	17.5	●	
215.0	248.0	15.0	16.5	●		236.0	276.0	16.0	20.0		●
215.0	251.0	12.5	18.0	●							
215.0	265.0	17.0	25.0	●							

These additional dimensions available on request.
Please contact Trelleborg sealing solutions.



Dimensions				Type	
d ₁	d ₂	b	f	TRJ	TRL
240.0	270.0	15.0	15.0	●	
240.0	270.0	17.0	15.0	●	
240.0	275.0	18.0	20.0	●	
240.0	278.0	17.0	19.0	●	
240.0	280.0	16.0	20.0	●	●
240.0	280.0	17.5	20.0	●	
245.0	270.0	13.0	12.5	●	
245.0	270.0	16.0	12.5	●	●
250.0	280.0	15.0	15.0	●	
250.0	280.0	16.0	15.0	●	●
250.0	285.0	18.0	17.5	●	
250.0	285.0	20.0	17.5	●	
250.0	288.0	19.0	19.0	●	
250.0	290.0	16.0	20.0	●	●
250.0	300.0	20.0	25.0	●	
250.0	303.0	20.0	26.5	●	
250.0	310.0	25.0	30.0	●	
253.0	285.0	11.0	16.0	●	
254.0	279.0	9.3	12.5	●	
254.0	292.0	15.9	19.0	●	
255.0	285.0	11.0	15.0	●	●
255.0	285.0	15.0	15.0	●	
255.0	295.0	16.0	20.0	●	●
255.0	310.0	18.0	27.5	●	
258.0	290.0	16.0	16.0	●	●
260.0	285.0	18.0	12.5	●	
260.0	290.0	16.0	15.0	●	●
260.0	290.0	19.0	15.0	●	
260.0	292.0	12.5	16.0	●	
260.0	298.0	17.0	19.0	●	
260.0	300.0	18.0	20.0	●	
260.0	300.0	20.0	20.0	●	
260.0	304.0	20.0	22.0	●	●
260.0	305.0	16.0	22.5	●	
260.0	305.0	22.0	22.5	●	
260.0	310.0	16.0	25.0	●	
260.0	310.0	18.0	25.0	●	
264.0	309.0	21.5	22.5	●	
265.0	300.0	16.0	17.5	●	●
265.0	310.0	16.0	22.5	●	
265.0	310.0	22.0	22.5	●	
270.0	300.0	15.0	15.0	●	●
270.0	310.0	16.0	20.0	●	
270.0	310.0	20.0	22.0	●	

Dimensions				Type	
d ₁	d ₂	b	f	TRJ	TRL
270.0	314.0	20.0	22.0	●	●
272.0	304.0	16.0	16.0	●	
272.0	304.0	16.5	16.0	●	
273.0	317.0	19.0	22.0	●	
275.0	310.0	15.0	17.5	●	
277.0	317.0	19.0	20.0	●	
280.0	310.0	15.0	15.0	●	
280.0	310.0	16.0	15.0	●	
280.0	318.0	15.0	19.0	●	
280.0	320.0	16.0	20.0	●	●
280.0	320.0	18.0	20.0	●	
280.0	320.0	20.0	20.0	●	
280.0	324.0	20.0	22.0	●	
280.0	325.0	24.0	22.5	●	
285.0	310.0	16.0	12.5	●	
285.0	325.0	16.0	20.0		●
285.0	325.0	18.0	20.0	●	
286.0	330.0	16.0	22.0	●	
290.0	320.0	15.0	15.0	●	
290.0	322.0	12.5	16.0	●	
290.0	330.0	16.0	20.0	●	
290.0	330.0	18.0	20.0	●	
290.0	330.0	20.0	20.0	●	
290.0	334.0	20.0	22.0	●	●
290.0	335.0	20.0	22.5	●	
290.0	350.0	25.0	30.0	●	
295.0	325.0	15.0	15.0	●	
295.0	335.0	15.0	20.0		●
295.0	335.0	16.0	20.0	●	
295.0	339.0	20.0	22.0	●	
300.0	330.0	14.0	15.0		●
300.0	332.0	15.0	16.0	●	
300.0	332.0	16.0	16.0	●	
300.0	335.0	16.0	17.5	●	
300.0	335.0	18.0	17.5	●	●
300.0	340.0	16.0	20.0	●	●
300.0	340.0	18.0	20.0	●	●
300.0	340.0	20.0	20.0	●	
300.0	340.0	25.0	20.0	●	
300.0	344.0	20.0	22.0	●	●
300.0	344.0	22.0	22.0	●	
300.0	350.0	22.0	25.0	●	

These additional dimensions available on request.
Please contact Trelleborg sealing solutions.



Dimensions				Type		Dimensions				Type	
d ₁	d ₂	b	f	TRJ	TRL	d ₁	d ₂	b	f	TRJ	TRL
300.0	350.0	25.0	25.0	●		340.0	370.0	20.0	15.0	●	
300.0	360.0	25.0	30.0	●		340.0	372.0	16.0	16.0	●	
300.0	364.0	25.0	32.0	●		340.0	373.0	16.0	16.5	●	
300.0	370.0	18.0	35.0	●		340.0	378.0	16.0	19.0	●	
305.0	340.0	15.0	17.5	●		340.0	380.0	18.0	20.0	●	
305.0	349.0	20.0	22.0	●		340.0	380.0	20.0	20.0	●	
305.0	355.0	15.0	25.0	●		340.0	384.0	20.0	22.0	●	
305.0	362.0	19.0	28.5	●		340.0	400.0	28.0	30.0	●	
310.0	350.0	17.5	20.0	●		345.0	389.0	20.0	22.0	●	
310.0	350.0	18.0	20.0	●	●	345.0	395.0	20.0	25.0	●	
310.0	354.0	20.0	22.0	●		346.0	390.0	20.0	22.0	●	
310.0	355.0	24.0	22.5	●		348.0	380.0	16.0	16.0	●	
310.0	370.0	28.0	30.0	●		350.0	380.0	16.0	15.0	●	
314.0	355.0	20.0	20.5	●		350.0	390.0	15.0	20.0	●	
315.0	347.0	13.0	16.0	●		350.0	390.0	16.0	20.0	●	
315.0	355.0	18.0	20.0	●		350.0	390.0	18.0	20.0	●	
315.0	359.0	20.0	22.0	●		350.0	390.0	20.0	20.0	●	●
315.0	360.0	20.0	22.5		●	350.0	394.0	20.0	22.0	●	●
315.0	365.0	20.0	25.0	●		350.0	394.0	22.0	22.0	●	
315.0	380.0	29.0	32.5	●		350.0	405.0	20.0	27.5	●	
317.0	361.0	20.0	22.0	●	●	355.0	379.0	20.0	12.0	●	
320.0	350.0	15.0	15.0	●		355.0	385.0	16.0	15.0		●
320.0	355.0	16.0	17.5	●	●	355.0	394.0	20.0	19.5	●	
320.0	360.0	18.0	20.0	●	●	355.0	410.0	25.0	27.5		●
320.0	360.0	20.0	20.0	●	●	360.0	390.0	18.0	15.0	●	
320.0	364.0	20.0	22.0	●	●	360.0	400.0	16.0	20.0	●	
323.0	363.0	16.0	20.0	●		360.0	400.0	18.0	20.0	●	
325.0	365.0	16.0	20.0	●	●	360.0	400.0	20.0	20.0	●	
325.0	365.0	20.0	20.0	●		360.0	404.0	20.0	22.0	●	●
325.0	369.0	22.0	20.0	●		360.0	410.0	22.0	25.0	●	
325.0	369.0	20.0	22.0	●		362.0	400.0	20.0	19.0	●	
325.0	375.0	22.0	25.0		●	362.0	406.0	19.5	22.0	●	
328.0	372.0	20.2	22.0	●		362.0	406.0	20.0	22.0	●	
330.0	370.0	18.0	20.0	●		362.0	406.0	22.0	22.0	●	
330.0	370.0	20.0	20.0	●	●	363.0	418.0	20.0	27.5	●	
330.0	374.0	19.0	22.0	●		365.0	405.0	18.0	20.0	●	
330.0	374.0	20.0	22.0	●	●	365.0	409.0	20.0	22.0	●	●
330.0	374.0	22.0	22.0	●		370.0	410.0	15.0	20.0	●	
335.0	375.0	18.0	20.0	●		370.0	410.0	18.0	20.0		●
335.0	379.0	20.0	22.0	●	●	370.0	410.0	20.0	20.0	●	
335.0	400.0	35.0	32.5	●		370.0	414.0	19.0	22.0	●	●
338.0	382.0	20.0	22.0	●		370.0	414.0	20.0	22.0	●	●
340.0	370.0	15.0	15.0	●							
340.0	370.0	18.0	15.0	●							

These additional dimensions available on request.
Please contact Trelleborg sealing solutions.



Dimensions				Type	
d ₁	d ₂	b	f	TRJ	TRL
370.0	414.0	25.0	22.0	●	
375.0	419.0	20.0	22.0	●	
375.0	419.0	22.2	22.0	●	
375.0	420.0	16.0	22.5	●	
378.0	428.0	18.5	25.0	●	
380.0	410.0	12.5	15.0	●	
380.0	420.0	15.0	20.0	●	
380.0	420.0	15.0	20.0		●
380.0	420.0	18.0	20.0	●	●
380.0	420.0	20.0	20.0	●	
380.0	420.0	20.0	20.0	●	
380.0	420.0	22.0	20.0	●	
380.0	424.0	20.0	22.0	●	●
380.0	435.0	25.0	27.5	●	
380.0	438.0	23.0	29.0	●	
380.0	440.0	25.0	30.0	●	
381.0	432.0	25.0	25.5	●	
384.0	414.0	15.0	15.0	●	
384.0	428.0	20.0	22.0		●
385.0	430.0	25.0	22.5	●	
385.0	438.0	32.0	26.5	●	
387.0	431.0	22.5	22.0	●	●
390.0	420.0	14.0	15.0	●	
390.0	420.0	16.0	15.0	●	
390.0	430.0	18.0	20.0	●	
390.0	430.0	20.0	20.0	●	
390.0	434.0	19.2	22.0	●	
390.0	434.0	20.0	22.0	●	●
390.0	440.0	22.0	25.0		●
390.0	464.0	20.0	37.0		●
395.0	430.0	18.0	17.5	●	●
395.0	431.0	18.0	18.0	●	
395.0	439.0	20.0	22.0	●	●
400.0	438.0	17.5	19.0	●	
400.0	440.0	14.0	20.0		●
400.0	440.0	18.0	20.0	●	
400.0	444.0	20.0	20.0	●	●
400.0	444.0	19.2	22.0	●	
400.0	444.0	20.0	22.0	●	●
400.0	445.5	22.0	22.7	●	
400.0	450.0	20.0	25.0	●	
400.0	450.0	22.0	25.0	●	●
405.0	455.0	22.0	25.0	●	
410.0	450.0	18.0	20.0		●

Dimensions				Type	
d ₁	d ₂	b	f	TRJ	TRL
410.0	450.0	20.0	20.0	●	
413.0	455.0	20.0	21.0	●	
415.0	445.0	20.0	15.0	●	
415.0	455.0	20.0	20.0	●	
415.0	459.0	20.0	22.0	●	
417.0	467.0	25.0	25.0	●	
420.0	460.0	18.0	20.0		●
420.0	460.0	19.0	20.0	●	
420.0	460.0	20.0	20.0	●	
420.0	470.0	20.0	25.0	●	
420.0	470.0	22.0	25.0	●	●
420.0	470.0	25.0	25.0	●	
430.0	470.0	20.0	20.0	●	
430.0	474.0	20.0	22.0	●	
430.0	480.0	20.0	25.0	●	
430.0	480.0	22.0	25.0	●	●
430.0	480.0	25.0	25.0	●	
430.0	490.0	25.0	30.0	●	
435.0	485.0	22.0	25.0	●	
435.0	485.0	30.0	25.0		●
437.0	487.0	19.8	25.0	●	
437.0	487.0	21.5	25.0	●	
440.0	469.0	12.5	14.5	●	
440.0	480.0	20.0	20.0	●	
440.0	490.0	20.0	25.0	●	
440.0	490.0	20.5	25.0	●	
440.0	490.0	22.0	25.0	●	●
440.0	490.0	25.0	25.0	●	
440.0	490.0	28.0	25.0		●
445.0	495.0	22.0	25.0	●	
446.0	486.0	16.0	20.0	●	●
447.0	497.0	22.0	25.0	●	
450.0	490.0	18.0	20.0		●
450.0	494.0	20.0	22.0	●	
450.0	500.0	20.0	25.0	●	
450.0	500.0	20.0	25.0		●
450.0	500.0	22.0	25.0	●	●
450.0	500.0	25.0	25.0	●	
454.0	500.0	18.0	23.0	●	
455.0	505.0	22.0	25.0		●
458.0	494.0	12.0	18.0	●	
460.0	500.0	18.0	20.0	●	

These additional dimensions available on request.
Please contact Trelleborg sealing solutions.



Dimensions				Type		Dimensions				Type	
d ₁	d ₂	b	f	TRJ	TRL	d ₁	d ₂	b	f	TRJ	TRL
460.0	500.0	20.0	20.0	●		528.0	578.0	22.0	25.0		●
460.0	510.0	22.0	25.0	●	●	530.0	565.0	20.0	17.5	●	
460.0	510.0	25.0	25.0	●		530.0	566.0	18.0	18.0	●	
460.0	510.8	20.6	25.4	●		530.0	570.0	22.0	20.0	●	
460.0	510.8	25.4	25.4	●		530.0	580.0	20.0	25.0	●	
460.0	520.0	30.0	30.0	●		530.0	580.0	22.0	25.0	●	
467.0	510.0	20.0	21.5	●		530.0	580.0	25.0	25.0	●	
467.0	510.0	25.0	21.5		●	530.0	580.8	22.2	25.4	●	
470.0	520.0	22.0	25.0	●	●	533.0	577.0	25.0	22.0	●	
470.0	520.0	25.0	25.0	●		540.0	584.0	20.0	22.0	●	
474.0	514.0	20.0	20.0	●		540.0	590.0	22.0	25.0	●	●
475.0	530.0	18.0	27.5	●	●	540.0	590.0	25.0	25.0		●
475.0	530.0	20.0	27.5	●		542.0	578.0	18.0	18.0	●	
477.0	527.0	22.0	25.0		●	545.0	595.0	22.0	25.0	●	
480.0	520.0	16.0	20.0	●		550.0	600.0	22.0	25.0	●	●
480.0	520.0	20.0	20.0	●		550.0	610.0	25.0	30.0	●	
480.0	530.0	22.0	25.0	●	●	555.0	605.0	22.0	25.0		●
480.0	530.0	25.0	25.0	●		556.0	600.0	22.0	22.0	●	
482.0	530.0	20.0	24.0	●		558.0	589.0	19.0	15.5	●	
485.0	535.0	22.0	25.0	●		560.0	598.0	19.0	19.0	●	
490.0	540.0	22.0	25.0		●	560.0	610.0	20.0	25.0	●	
495.0	545.0	25.0	25.0		●	560.0	610.0	22.0	25.0	●	
497.0	538.0	20.0	20.5	●		570.0	620.0	22.0	25.0	●	●
500.0	540.0	20.0	20.0	●		570.0	620.0	25.0	25.0	●	
500.0	544.0	20.0	22.0	●		575.0	611.0	16.0	18.0	●	
500.0	550.0	22.0	25.0	●		575.0	625.0	22.0	25.0	●	
500.0	550.0	22.0	25.0	●	●	580.0	605.4	12.7	12.7	●	
503.0	552.0	20.0	24.5	●		580.0	615.0	20.0	17.5	●	
508.0	555.0	22.0	23.5	●		580.0	616.0	16.0	18.0	●	●
508.0	558.0	22.0	25.0	●		580.0	630.0	22.0	25.0	●	
508.0	558.0	25.0	25.0	●		580.0	630.0	34.0	25.0	●	
510.0	550.0	20.0	20.0	●		586.0	646.0	22.0	30.0	●	
510.0	554.0	20.0	22.0	●		590.0	640.0	20.0	25.0	●	
510.0	560.0	20.0	25.0	●		590.0	640.0	22.0	25.0	●	
510.0	560.0	22.0	25.0	●		596.0	646.0	22.0	25.0	●	
520.0	564.0	20.0	22.0	●		600.0	632.0	12.5	16.0	●	
520.0	570.0	19.0	25.0	●		600.0	640.0	20.0	20.0	●	
520.0	570.0	22.0	25.0	●		600.0	650.0	22.0	25.0	●	
520.0	570.0	25.0	25.0	●		600.0	650.0	30.0	25.0	●	
520.0	570.8	20.6	25.4	●		600.0	664.0	25.0	32.0		●
520.0	572.0	25.0	26.0	●		603.0	640.0	16.0	18.5	●	
525.0	575.0	22.0	25.0	●	●	604.0	640.0	18.0	18.0	●	
527.0	587.0	30.0	30.0	●							
527.0	587.0	38.0	30.0		●						

These additional dimensions available on request.
Please contact Trelleborg sealing solutions.



Dimensions				Type	
d ₁	d ₂	b	f	TRJ	TRL
610.0	660.0	22.0	25.0	●	
614.0	659.0	20.0	22.5	●	
615.0	665.0	24.5	25.0	●	
615.0	679.0	24.5	32.0	●	
620.0	670.0	22.0	25.0	●	
620.0	684.0	25.0	32.0	●	●
625.0	689.0	25.0	32.0	●	
640.0	680.0	20.0	20.0		●
650.0	689.0	19.0	19.5	●	
650.0	690.0	20.0	20.0	●	
650.0	700.0	22.0	25.0		●
650.0	714.0	25.0	32.0	●	●
650.0	720.0	28.5	35.0		●
660.0	710.0	22.0	25.0	●	
660.0	724.0	25.0	32.0	●	
660.0	724.0	28.0	32.0		●
665.0	729.0	25.0	32.0	●	●
670.0	714.0	22.0	22.0		●
670.0	735.0	25.0	32.5	●	
680.0	730.0	20.0	25.0	●	
681.0	744.5	25.4	31.7	●	
685.0	749.0	25.0	32.0	●	
686.0	740.0	25.0	27.0	●	
700.0	764.0	25.0	32.0	●	●
710.0	760.0	20.0	25.0	●	
710.0	770.0	30.0	30.0	●	
710.0	774.0	25.0	32.0	●	●
715.0	779.0	25.0	32.0	●	
720.0	760.0	18.0	20.0		●
730.0	794.0	25.0	32.0	●	●
735.0	793.0	25.0	29.0		●
740.0	780.0	18.0	20.0		●
740.0	790.0	20.0	25.0	●	
744.0	794.0	25.0	25.0		●
744.0	808.0	25.0	32.0	●	
750.0	780.0	18.0	15.0	●	
750.0	789.0	19.0	19.5	●	
750.0	810.0	30.0	30.0	●	
750.0	814.0	25.0	32.0	●	
760.0	800.0	20.0	20.0	●	
760.0	820.0	30.0	30.0	●	
762.0	803.0	25.4	20.5		●
762.0	825.5	25.4	31.7	●	
765.0	825.0	26.0	30.0	●	

Dimensions				Type	
d ₁	d ₂	b	f	TRJ	TRL
770.0	845.0	27.5	37.5		●
775.0	839.0	25.0	32.0	●	
775.0	839.0	31.0	32.0		●
777.0	841.0	25.0	32.0	●	
780.0	820.0	18.0	20.0	●	●
780.0	844.0	25.0	32.0	●	
786.0	836.0	25.0	25.0	●	
790.0	850.0	30.0	30.0	●	
790.0	854.0	25.0	32.0	●	
800.0	860.0	30.0	30.0	●	
800.0	864.0	25.0	32.0	●	●
800.0	870.0	30.0	35.0	●	
810.0	860.0	25.0	25.0	●	
810.0	870.0	25.0	30.0	●	
810.0	874.0	25.0	32.0		●
820.0	884.0	25.0	32.0	●	
832.0	870.0	19.0	19.0	●	
840.0	904.0	25.0	32.0	●	
850.0	914.0	25.0	32.0	●	●
860.0	920.0	25.0	30.0	●	
860.0	924.0	25.0	32.0		●
870.0	934.0	25.0	32.0		●
880.0	944.0	25.0	32.0	●	
889.0	970.0	21.0	40.5		●
890.0	954.0	25.0	32.0	●	
898.0	960.0	30.0	31.0		●
900.0	960.0	30.0	30.0	●	
910.0	966.0	25.0	28.0		●
920.0	984.0	25.0	32.0	●	
935.0	999.0	25.0	32.0	●	
940.0	995.0	25.0	27.5		●
940.0	1,000.0	30.0	30.0	●	
950.0	1,000.0	25.0	25.0	●	
950.0	1,010.0	30.0	30.0	●	
960.0	1,024.0	25.0	32.0	●	
1,000.0	1,050.0	25.0	25.0		●
1,000.0	1,064.0	25.0	32.0	●	
1,020.0	1,084.0	25.0	32.0	●	
1,055.0	1,119.0	25.0	32.0		●
1,060.0	1,124.0	25.0	32.0		●
1,150.0	1,214.0	25.0	32.0	●	
1,220.0	1,284.0	25.0	32.0		●

These additional dimensions available on request.
Please contact Trelleborg sealing solutions.



Dimensions				Type	
d ₁	d ₂	b	f	TRJ	TRL
1,250.0	1,300.0	22.0	25.0		●
1,250.0	1,314.0	25.0	32.0	●	
1,320.0	1,398.0	32.0	39.0	●	
1,320.0	1,420.0	49.0	50.0		●
1,580.0	1,644.0	25.0	32.0		●
1,790.0	1,854.0	24.7	32.0		●
1,890.0	1,954.0	25.0	32.0		●

These additional dimensions available on request.
Please contact Trelleborg sealing solutions.



Cassette Seal







■ Cassette Seal

■ General Description

The Cassette Seal has been developed to meet the ever-increasing requirements of long service life, high functional reliability, environmental safety, simple handling and superior total economy. Cassette Seals are fully enclosed seals with an integrated sealing system, that performs the function of oil seal, wear sleeve and dust protection in one unit. No extra components such as shaft sleeves or dirt protection are needed.

Unique to all the Trelleborg Sealing Solutions Cassette seals is that the sealing lip is fixed on the stationary part of the hardware. Because of this the sealing force is constant, independent of the rotary speed. Cassette seals consist of several individual features working together, built into one unit and for this reason they are called "Systems".

Cassette Seals are originally designed at FORSHEDA AB in Sweden under the trade name STEFA.

■ System 500

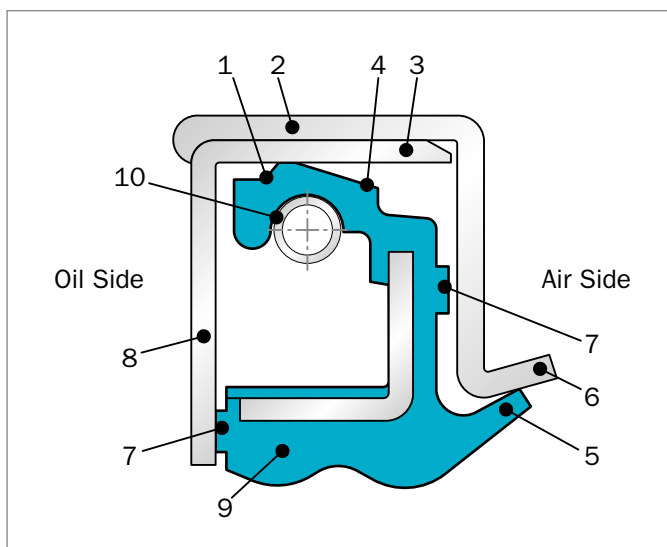

Figure 46: System 500

System 500, the original Unitized Wheel Hub Seal for heavy-duty vehicles, is designed for rotating hubs. The inner section of the System 500 is secured against the shaft. The outer section, press fitted into the wheel hub, rotates together with the hub around the inner section, creating a completely enclosed seal. Dirt and water, the major enemies of hub seals, are effectively kept at distance, whilst the lubrication of the rubber lip remains intact. This decreases friction and increases seal life accordingly.

THE MAIN FEATURES OF THE SYSTEM 500 ARE:

- The sealing (1) element is non-rotating, which means that the radial force is kept unchanged at various speeds.
- The sealing surface (2) is in close contact with the wheel hub, which gives an excellent heat transfer.
- The structure of the sealing counterface (3) has been chosen after several thousands of test hours. The position of the sealing lip ensures best lubrication.
- The sealing lip (4) normally has bi-directional TURBO-pattern (see page 116).
- Integral prelubricated dust-sealing (5) functions.
- The protruding conical part (6) of the case deflects heavier particles due to the centrifugal force.
- The excluding lip (5) protects against water splash and finer particles.
- Molded distance lugs (7) automatically locate the sealing element in the right position.
- The lugs (7) are spaced and dimensioned to ensure the sealing lip has adequate lubrication.
- The inner case (8) also protects the sealing lip from direct oil spray caused by taper roller bearings.

The robust ribs (9) give:

- a firm seat on the shaft
- a smooth sliding during installation
- a positive static seal even if one of the ribs is located on a defective shaft surface
- The compression spring (10) maintains the radial force. The initial force exerted by the sealing element will in some applications reduce due to aging of the rubber exposed to heat, load or chemical action.
- For such applications where the seal is exposed to dirty environment, i.e. off road use, the System 500 can be equipped with an additional specially developed dirt protection, the HRV seal.
- In cases where the space does not allow the use of the HRV seal, the System 500HD, a derivative of System 2000 (with additional dust lip), can be used. It has the same outside dimensions, but an extra dust lip inside. Since the casing is identical to System 500 it is readily available in the same sizes. Please contact your local Trelleborg Sealing Solutions marketing company for more details.



■ System 2000

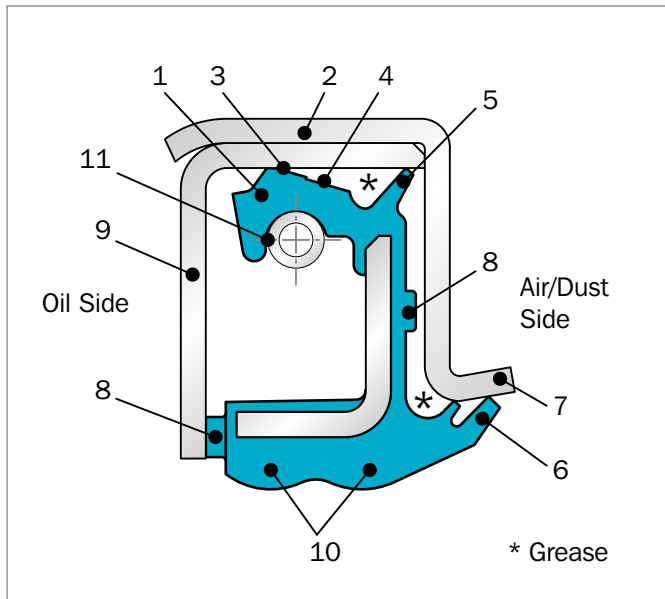

Figure 47: System 2000

System 2000 is a Unitized Cassette Seal suitable for wheel hubs working in heavily polluted environments, like agricultural and construction vehicles.

Like for System 500 and System 3000, the inner section of the System 2000 is secured against the shaft and it is rubberized, while the outer section is press fitted into the bore, and rotates together with the hub around the inner section, creating a completely enclosed seal; the outer diameter can be provided by a sealing paint to increase the static sealing functionality in critical conditions, for example when the bore surface is porous or scratched.

Dirt and water, the major enemies of the off road hub seals, are effectively kept at distance thanks to the many sealing lips, whilst the lubrication of the rubber lip remains intact and is assured by the packing grease. This decreases friction and increases seal life accordingly.

System 2000 is limited in speed compared to System 500, due to the higher number of internal dust sealing lips.

MAIN FEATURES OF SYSTEM 2000

- The sealing (1) lip, if the Cassette Seal is assembled in rotating wheel hubs, is non-rotating and this feature allows the radial force to be kept stable at various speeds.
- The outer sealing surface (2) is in close contact with the wheel hub, which gives an excellent heat transfer.
- The structure of the sealing counter face (3) has been chosen after several thousand test hours. The position of the sealing lip ensures best lubrication.
- The sealing lip (4) normally has a bi-directional TURBO pattern engraved, that improves the sealing capability.
- The internal dust-sealing lip (5), located just behind the primary sealing lip, creates a supplementary grease lubrication chamber near the sealing edge and guarantees an extra barrier against dirt/pollution/water ingress
- External double dust-sealing lips (6) with tailored progressive contact load, provides an optimized protection against contaminants while keeping friction low.
- The protruding conical part (7) of the case deflects heavier particles thanks to the centrifugal force.
- Molded distance lugs (8) automatically locate the sealing element in the right position during assembly; they are spaced and dimensioned to ensure adequate lubrication to the sealing lip.
- The inner case (9) protects the sealing lip from direct oil spray caused by tapered roller bearings.
- The inner diameter is provided by two robust ribs (10) that provide a smooth sliding during installation and a positive static seal on scratched shaft surfaces.
- The compression spring (11) energizes the sealing lip keeping a constant radial force during life time.

For such applications where the seal is exposed to extremely dirty and wet environments, i.e. heavy-duty tractors, the System 2000 can be also equipped with an additional specially developed HRV seal lip, that looks like an external V-Ring lip sliding against the shaft on the dust side.



System 3000

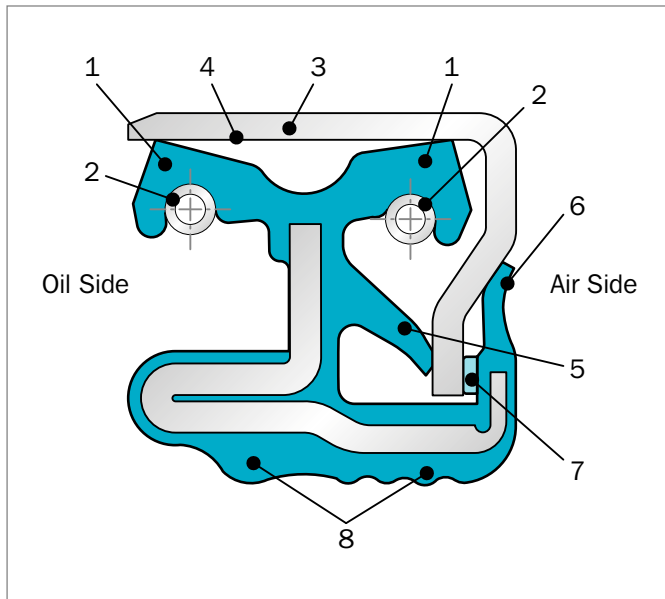

Figure 48: System 3000

System 3000 is a specifically designed Cassette Seal for rotating hubs working in very heavily polluted environments, like tractors operating in rice fields, forestry machinery and dumper trucks operating in quarries and mines.

The design of System 3000 has been specifically developed for long term sealing effectiveness; the internal labyrinth lips have been optimized for friction reduction and flexibility.

Mud-box tests realized in laboratories according to the most demanding customer specifications, are showing a significant improvement in life time performance compared to other Cassette Seals. System 3000 has excellent ability seal oil while excluding water, dust and mud.

Thanks to its optimized design, System 3000 keeps the same ability to sustain eccentricities, over-pressure and shaft misalignment as the standard Rotary Oil Seals.

MAIN FEATURES OF SYSTEM 3000

- System 3000 cassette has tandem energized sealing lips (1) that are stationary against the rotating hub; this feature lets the two lips effectively seal oil and contaminants, and are effectively lubricated by the intermediate grease chamber.
- The twin compression springs (2) are energizing the tandem sealing lips, keeping a constant radial force during life time.
- The outer sealing surface (3) is in close contact with the wheel hub, which gives an excellent heat transfer.
- The structure of the sealing counter face (4) has been chosen after several thousand test hours. The position of the sealing lip ensures optimal lubrication.
- Tailored internal axial dust sealing lip (5), has a steady contact with metal counter-face even in case of eccentricity or axial play. It creates a double labyrinth chamber that effectively traps any pollution.
- An external dust-sealing lip (6), is working again with an axial load minimizing in this way friction and wear, and provides the first barrier against contaminants.
- Molded distance lugs (7) locate the sealing element in the right position during assembly of the shaft.
- The inner diameter combines a large rib and multiple smaller ribs (8) in order to provide a smooth sliding during installation and secure sealing against scratched shafts.

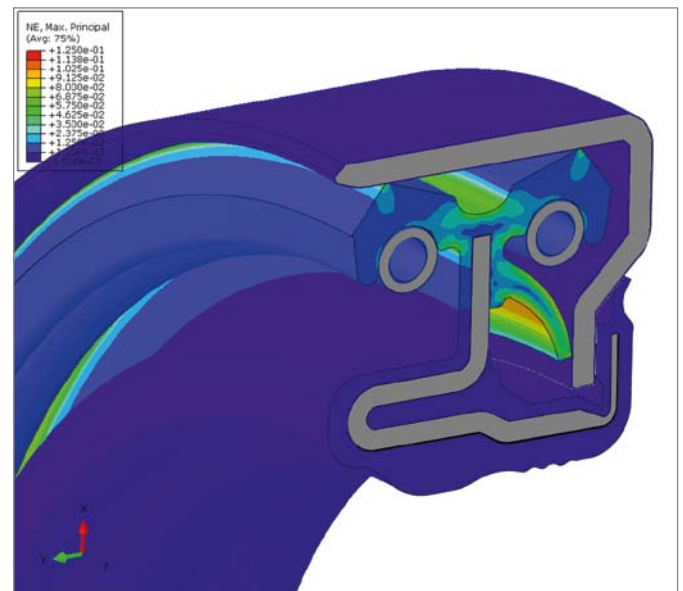

Figure 49: Friction optimization through FEA



■ System 5000

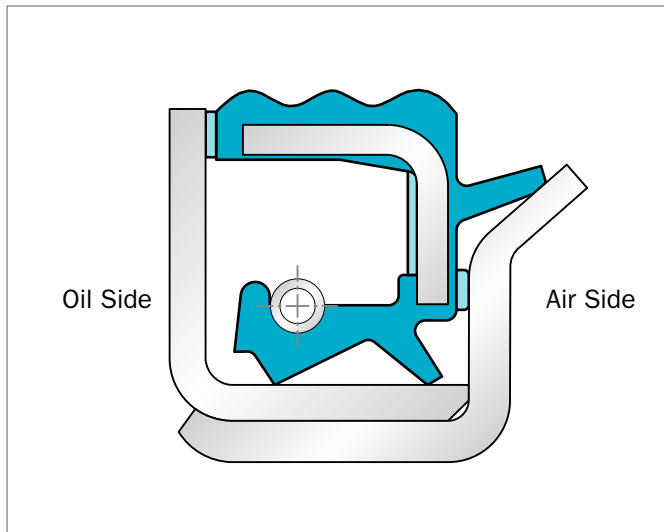

Figure 50: System 5000

The System 5000 is, like System 500 and System 3000, a fully enclosed seal, but is designed for rotating shafts. The System 5000 has the same features but the design has been inverted, i.e. the sealing element is fixed in the stationary housing and the casing components rotates with the shaft.

The System 5000 is used to prevent oil from leaking out of a bearing housing, i.e. a differential pinion housing for rear axles on trucks, and at the same time preventing road dirt, salt and water splash from entering.

The design is compact and integrates the necessary shaft counterface as well as providing dirt exclusion. The dirt exclusion function consists of two rubber lips, one axial and one radial, the space between these filled with grease, and the rotating seal case, which acts as an effective deflector due to the centrifugal force.

TURBO-PATTERN - HYDRODYNAMIC SEALING AIDS

TURBO is the Trelleborg Sealing Solutions designation of a range of hydrodynamic sealing aids supporting the sealing function. The hydrodynamic sealing aids are located on the air side of the main sealing lip in the form of ribs or other geometrical figures of a variety of shapes. Optimum sealing conditions are attained when a thin film of lubricant is formed so that the lip does not come in contact with the sealing counterface. Such conditions are created by the TURBO-pattern, which brings about a pumping effect. The pumping effect starts at relatively low shaft speed, and is understood as the capacity of the seal lip to pump the media to be sealed back from the air side to the media side.

In order to avoid leakage at standstill or low speed, the TURBO-pattern includes a static edge, which provides a continuous contact line against the counterface. The frictional loss of the seals provided with TURBO-pattern is significantly lower than that caused by seals without hydrodynamic sealing aids. A lower friction does also allow higher-rotary speeds, or provides longer service life.

The Turbo pattern is available in three versions: bi-directional, left hand or right hand rotation. The standard is bi-directional as most applications have alternating movement of the hub or shaft. If an application has rotation in one direction only, the corresponding left or right hand type can be specified. The direction of rotation is always defined as seen from the air side.



■ System CLS 1500

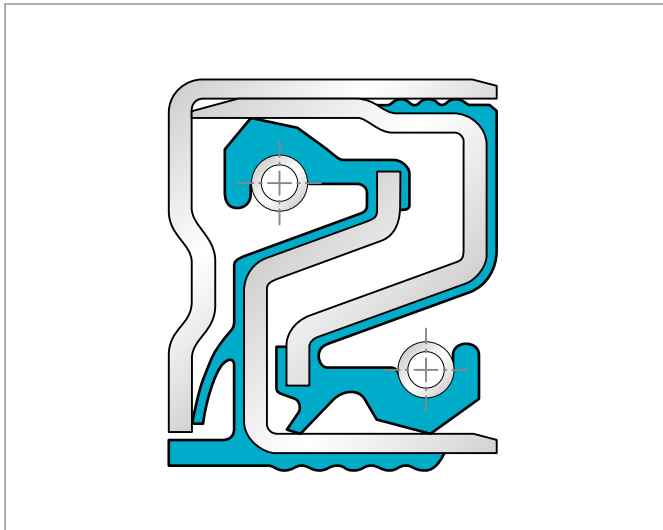

Figure 51: System CLS 1500

CLS 1500 was specially designed for applications in agriculture, vehicle axles, hubs and industrial gearboxes. Its design provides more protection against pollution due to an enlarged space for the grease between the sealing lips, which have also been improved in order to reduce friction and wear.

In the course of this, the oil-side lip based on world class standards is open to the oil and thus better cooled.

Moreover, the design is not only characterized by a very good static sealing effect and an optimized heat dissipation of the Metal/Rubber-OD, but also by lower production costs, since crimping and grinding are not necessary.

During assembly, a double metal frame that adds further stability protects the seal from deformation.

Various endurance tests have proven that System CLS 1500 neither causes any measurable leakage in hot oil tests nor any oil contamination in slurry tests. For that reason, System CLS 1500 is a pioneer in enhancing performance in heavy-duty applications.

CLS 1500 will be a customized product and is available on request to adjust the design to the most proper way for the requested application. Please contact your local Trelleborg Sealing Solutions marketing company for more information.

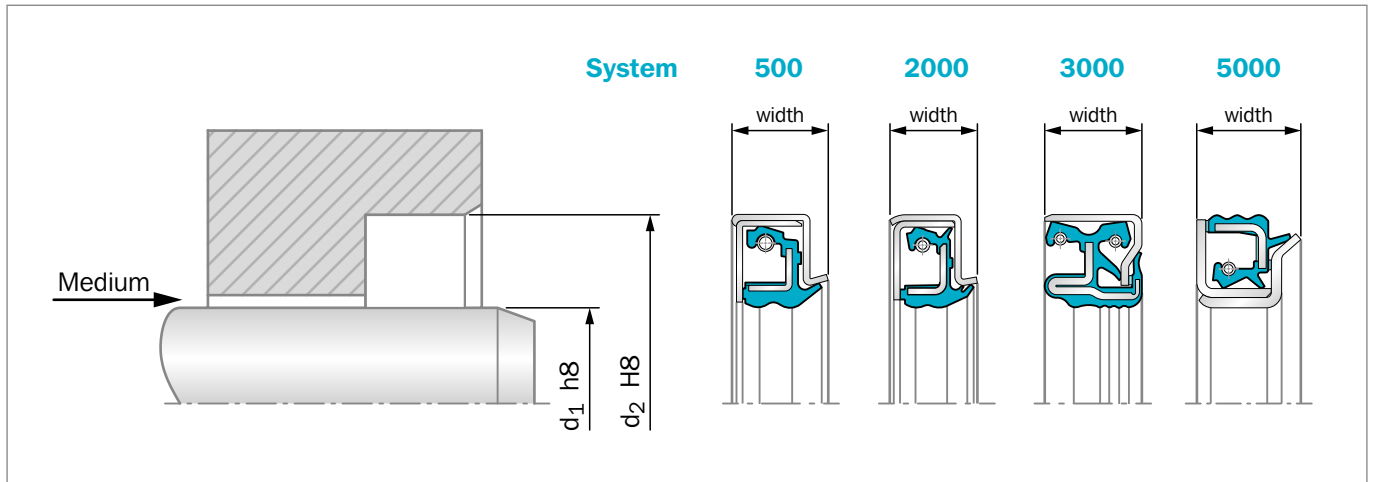

Figure 52: Installation Drawing

Table 39: Standard Dimensions

ID d ₁	OD d ₂	Width	System 500			System 2000		System 3000		System 5000		
			NBR	HNBR	FKM	NBR	HNBR	NBR	HNBR	NBR	HNBR	FKM
85	140	17								•	•	•
90	130	17	•	•	•							
100	130	17	•	•	•							
100	140	17	•	•	•							
110	140	17	•	•	•							
111	146	17	•	•	•							
120	160	17	•	•	•							
125	160	17	•	•	•							
128	164	17	•	•	•							
130	160	17	•	•	•			•	•			
130	170	17	•	•	•							
135	165	17	•	•	•							
140	170	17	•	•	•							
143.3	190.5	16				•	•					
145	175	17	•	•	•							
149.9	176	16	•	•								
150	180	17						•	•			
155	190	17	•	•	•							
158	188	16					•					
160	191.5	16.5								•		
160	196	17	•	•		•	•					
178	205	17	•	•	•							
178	207.7	16.5						•	•			
187	230	17	•	•	•							



ID d ₁	OD d ₂	Width	System 500			System 2000		System 3000		System 5000		
			NBR	HNBR	FKM	NBR	HNBR	NBR	HNBR	NBR	HNBR	FKM
190	230	17	●	●	●			●				
250	290	17	●	●								
320	360	19	●	●								

Table 40: Materials

Standard Material*	TSS Material Code	Standard Metal Case	Standard Spring
NBR (70 Shore A)	4N063	Carbon steel	Carbon steel
HNBR (75 Shore A)	4H063	Carbon steel	Carbon steel
FKM (75 Shore A)	4V063	Carbon steel	Carbon steel

* Special grades and other materials on request.

ORDERING EXAMPLE

Due to various combinations (HRV-additional dirt seal + coating), please contact your local Trelleborg Sealing Solutions marketing company when ordering Cassette Seals.



■ Materials

METAL CASE

The cases are normally stamped of cold rolled steel sheet, EN 10 130 - Fe P04. The high demands on the metal cases; high surface finish, free from scratches etc., calls for production using special tools.

COMPRESSION SPRING

For the spring, spring steel SS14 1774 - DIN 17223 - is normally employed. If resistance to corrosion is required, stainless steel SS 14 2331 - DIN 1.4301 is used.

SEALING ELEMENT

The material of the sealing element must be selected according to the working conditions of the seal and the environmental conditions.

Some of the requirements associated with environmental considerations are:

- good chemical resistance
- good resistance to heat and low temperature
- good resistance to ozone and weathering

The functional demands include:

- high resistance to wear
- low friction
- low compression set
- good elasticity

In addition, cost considerations make ease of processing a desirable feature.

No material is available today, which satisfies all these requirements. The choice of material is therefore always a compromise between the relative significance of the factors involved.

Trelleborg Sealing Solutions has succeeded in developing a Nitrile Rubber compound (NBR), which exhibits good all-round properties, and for this reason is the compound most commonly used.

The materials normally used for the sealing element are: Nitrile Rubber (NBR), Hydrogenated Nitrile Rubber (HNBR) and Fluorinated Elastomers (FKM).

The additional dirt seal is normally made of Nitrile Rubber. Nitrile Rubber is the basis material for Cassette Seals, as it covers most standard application requirements for general oil- and grease resistance. It is from function and cost aspects the best choice when temperature is not excessively high. Nitrile can be used up to +125 °C in non-aggressive oils. However for long term use, or in aggressive oils, service temperature is reduced to +80 °C.

Nitrile generally has good mechanical properties and the material used for Cassette Seals is optimized for best heat and abrasion resistance.

Hydrogenated Nitrile Rubber is a further development of NBR, where the chemical double bonds in the polymer molecules are saturated with hydrogen. Since the double bonds of NBR are sensitive to heat and ozone, the HNBR will be superior to NBR in heat, ozone and weather resistance. It can generally be used up to +150 °C in non-aggressive media, however for long term use maximum service temperature is +120 °C.

The HNBR for the Cassette Seal is fully saturated and thus well suited for use in aggressive oils. The temperature should however be limited at +120 °C. As saturated HNBR cannot be vulcanized with sulfur, the material has resistance to most hypoid oils up to about +120 °C for long term use.

Low friction and high abrasion resistance are additional typical features.

Fluorinated elastomers give peak performance regarding heat and chemical resistance. They can be used up to +200 °C for long term use and are generally very resistant to oil, grease and fuels. Their ozone and weather resistance is outstanding.

Mechanical and low temperature properties are however lower compared to Nitrile. Thus Fluoroelastomers should be considered only when the material properties are fully used. Some oil additives like amines and high pH-values may damage Fluoroelastomers when used at high temperatures.

TEMPERATURE RESISTANCE

Increasing temperature accelerates the aging of rubber, the elongation decreases, and the compression set increases and finally the material becomes hard and brittle. Cracks at the sealing edge are a typical indication that the seal has been exposed to excessively high temperature. The aging of the rubber has appreciable significance on the useful life of the seal. It can generally be said that a temperature increase of +10 °C (in air) will half the theoretical useful life of the rubber.



Low temperatures are generally not a big problem since the seals themselves generate heat by friction when rubbing against another surface. If the seal has been chilled down, its original properties will return as soon as it is warmed up again. Some leakage may however arise during the start-up phase, before the rubber material is softened by friction heat.

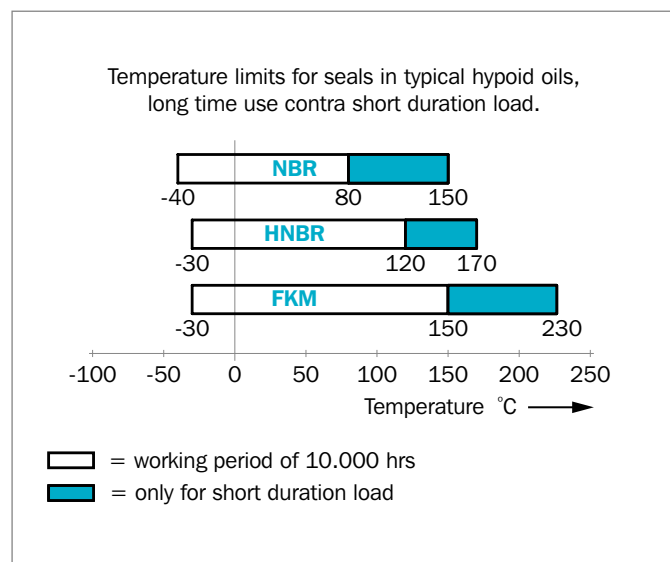

Figure 53: Temperature recommendations in typical hypoid oils

The temperature limits for the standard materials in hypoid oils are illustrated in Figure 53. They should only be regarded as approximate, since the oil type and the time of exposure also affects the materials. The temperature ranges within the shaded areas in the illustrations are temperatures that can be allowed only for certain periods of time. The higher the temperature, the shorter the period of time. At low temperatures, time has no influence on aging.

However, seals are not often working in air as the only media. Temperature limits in combination with other oils and media can be obtained from your local Trelleborg Sealing Solutions marketing company.

OIL RESISTANCE

Innumerable types of oils are available on the market and each of these has a different effect on the rubber. In addition, a given type of oil from a different manufacturer may have a different influence.

The additives in the oil generally affect the rubber. This is the case with hypoid oil, which contains sulfur. Since sulfur is used as a vulcanizing agent for Nitrile Rubber, the sulfur additive in the oil acts as a vulcanizing agent at temperatures above +80 °C. As a result of this secondary curing, Nitrile rubber will rapidly become hard and brittle. Hydrogenated Nitrile and

Fluorinated rubbers, which are not vulcanized with sulfur, can therefore be used for this type of oil, even though the operating temperature may not require these.

Oxidized oils represent another example illustrating the difficulty of tabulating the oil resistance of rubber materials. These oils are oxidized during operation and their properties will therefore change substantially.

Due to the above, no detailed information is given about resistance to certain types of oils. In case of questions or doubt, it is advisable to contact your local Trelleborg Sealing Solutions marketing company who have access to the many years of in-house testing made by FORSHEDA AB. Additional testing can be carried out in specific oil types provided a sufficient sample is available.

CHEMICAL RESISTANCE

Since the Cassette seals are normally exposed to oil or grease, and not other chemicals, tables for chemical resistance to different media are not included. For guidelines about chemical resistance, please look under "Radial Oil Seals" or contact your local Trelleborg Sealing Solutions marketing company.

Application

SYSTEM 500, 2000, 3000, 5000 AND CSL 1500

For the System 500, 2000, 3000, 5000 and CSL 1500, requirements on the shaft finish and hardness are less stringent in comparison with traditional radial shaft seals. A simple fine turning operation gives an adequate surface on the shaft as well as for the housing bore. Diameter tolerances and finish values are shown in Figure 54 and Figure 55.

As the sealing elements have built in counterfaces of their own, no wear on the shaft itself will occur and consequently no hardening of the shaft is necessary.

Suitable lead in chamfers facilitates the installation of the seal.

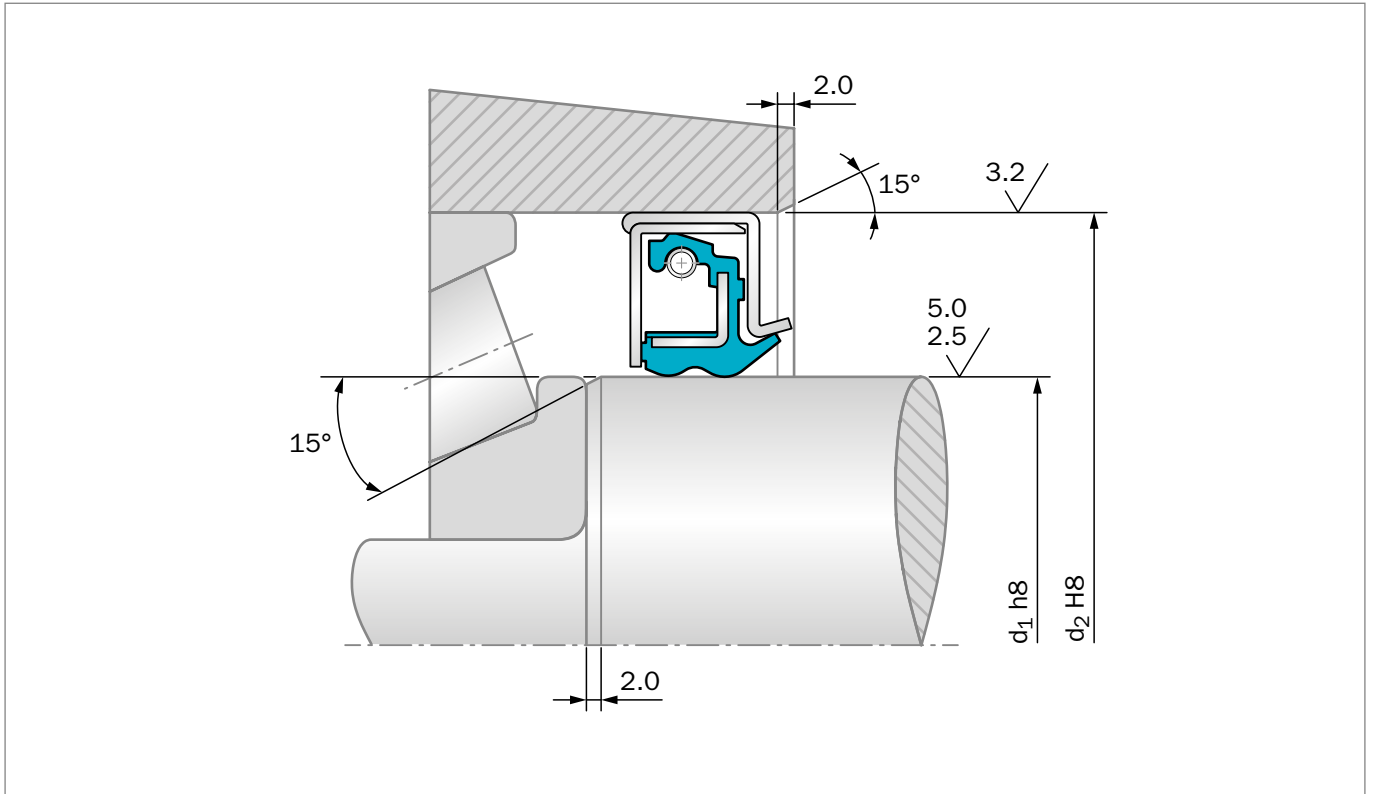

Figure 54: System 500 in wheel hub application (similar for System 2000 and System 3000)

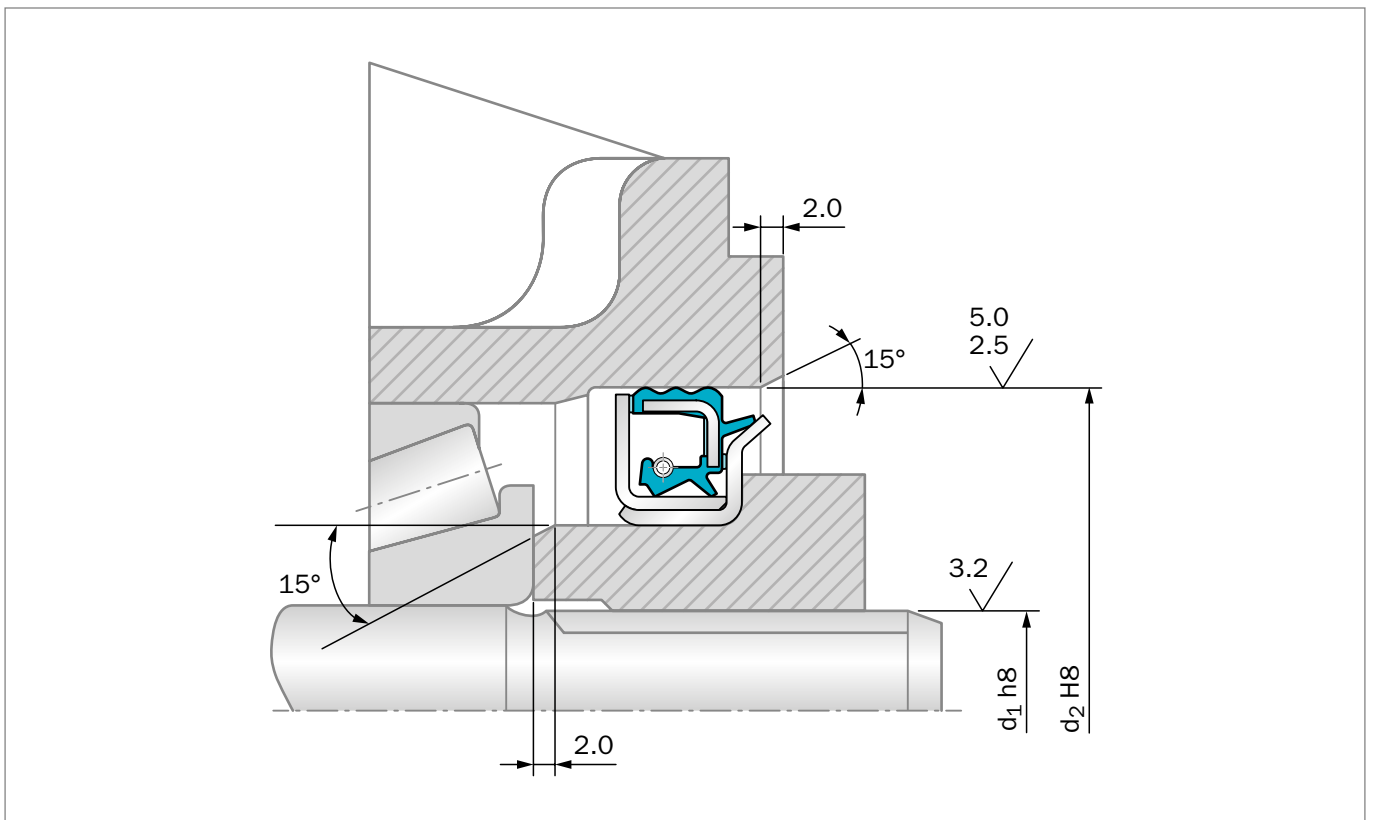

Figure 55: System 5000 in pinion application



SHAFT RUN OUT

Shaft run out should as far as possible be avoided or kept within a minimum. At higher speeds there is a risk that the inertia of the sealing lip prevents it from following the shaft movement. The seal must be located next to the bearing and the bearing play is maintained at the lowest possible value.

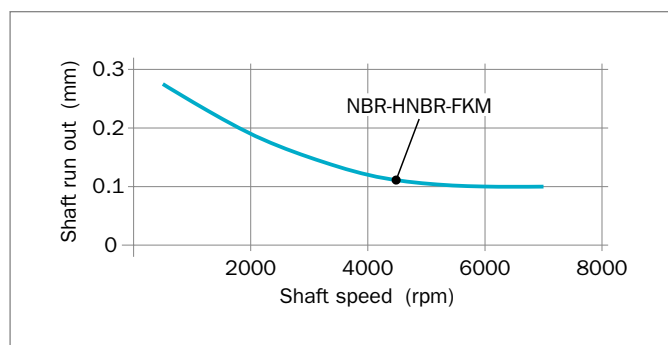

Figure 56: Permissible run out of the shaft

ECCENTRICITY

Eccentricity between shaft and housing bore centers should be avoided in order to eliminate unilateral load of the lip.

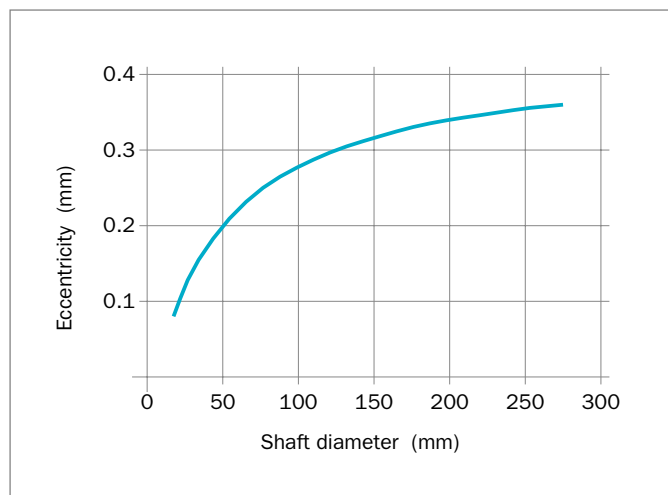

Figure 57: Permissible eccentricity

AXIAL MOVEMENT

Axial movement, including what can be considered as normal bearing play, should be within ± 0.1 mm. The Cassette seal will function at larger movements, however this may cause a larger wear on support lugs and in the end shorter lifetime.

PRESSURE

Any difference in pressure from one side of the seal to the other should be avoided. Since the seal is developed for ventilated applications, a pressure difference will in the end lead to a decreased lifetime or leakage. In some applications, a pressure difference up to 0.05 MPa could be accepted, but tests should be carried out for each case.

SPEED

The permissible speed of rotation at the sealing point for the various seal designs stated below, assumes normal running conditions, e.g. oil retention and no pressure differential across the seal.

Table 41: Max Surface Speed

Type of Seal	max. Surface Speed (m/s)
System 500	10
System 2000	5
System 3000	4
System 5000	15
CLS 1500	4

START/OPERATING TORQUE

Due to transferred assembly forces inside the Cassette Seal, the Cassette Seal absorbs higher torque than a standard radial seal. See also the Installation section on page 126.

HRV - ADDITIONAL DIRT SEAL

The HRV seal is an all rubber seal. It is designed for use as a complementary seal for the System 500 and 2000 in dirty applications such as off-road. The main sealing is against small particles such as dust, but also dirt and splash. Since the sealing action is axial, it can absorb some axial displacement.

The HRV seal is bonded directly to the outer case of the cassette. The design is similar to the FORSHEDA V-Ring with a body and a flexible conical shaped sealing lip with an integral resilient "hinge" (see Figure 58).

The HRV seal rotates, due to the outer case being press fitted into the bore, and seals axially against a stationary counter face. During rotation the sealing lip rubs against the counterface under a contact pressure calculated to achieve a sealing function. The HRV seal also operates as a deflector ring, and its centrifugal action contributes to a good sealing function.



Due to the centrifugal force, the contact pressure of the lip decreases with increase in speed. The contact pressure also varies with the fitted width.

The counterface for the HRV seal can consist of a suitable surface on the existing hardware or a steel casing adapted to suit the specification for the seal counterface.

The HRV seal:

- seals against outer media like dirt and dust
- has a deflecting function due to the centrifugal force

The requirements on the counterface against which the sealing lip works are rather low. The requirements are more or less determined by the media to be sealed. A finish-turned, polished surface with a surface roughness of Ra 1.6 to 2.0 μm is normally adequate. For sealing against liquid and dirt, Ra 0.8 to 1.6 μm is recommended. However, the character of the surface is of greater importance than the actual surface roughness value. For turned surfaces, it is recommended to buff the surface with fine emery cloth to remove any sharp peaks, which could tear the rubber surface apart and destroy the sealing function, shortening seal life time.

It is also necessary to ensure that the counterface is perpendicular to the shaft, flat and free from scratch marks and other damage within the sealing area. This is especially important when sealing fluids and fine particles.

To achieve the full effect of the deflector action, the HRV seal should be designed in a relatively open space.

The fitted width dimension will be stated on the corresponding product drawing.

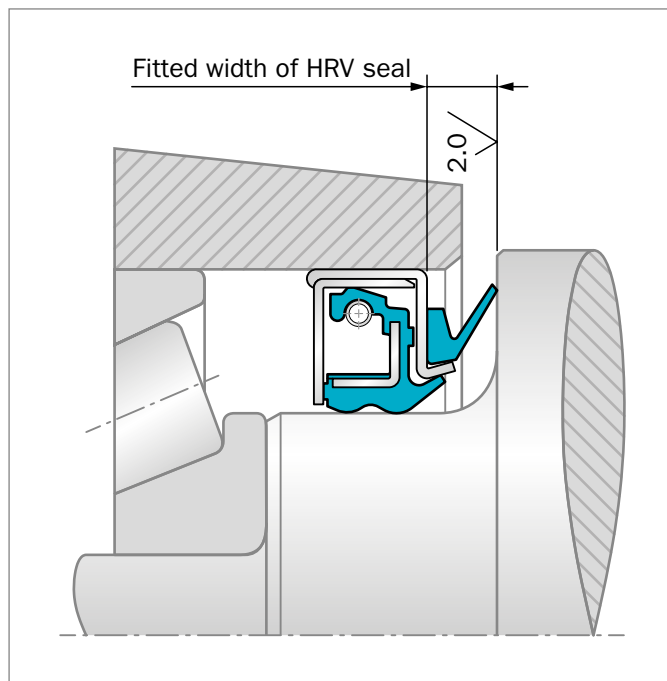

Figure 58: System 500 with HRV seal

■ Installation

As the Cassette Seal incorporates all functions as seal, shaft counterface and dust protection, there is no need for extra components such as exchangeable shaft sleeves or dirt protection.

This means fewer parts to stock and handle.

When handling and fitting traditional shaft seals there is always a risk of damaging the shaft surface or sealing lips and of improper installation. As the Cassette Seal is fully enclosed the vital sealing components cannot be touched or damaged during the installation.

SYSTEM 500, 2000, 3000 AND CSL 1500

System 500, 2000, 3000 and CSL 1500 Cassette Seal designs require a high assembly force to push the cassette inside the bore compared with the force needed to push the shaft inside the cassette. As such, the seals must first be assembled in the bore, with the shaft inserted afterwards.

Trelleborg Sealing Solutions recommends following this assembly procedure:

- Ensure the inner surface of the bore and any lead-in chamfers are in accordance with technical specifications and free from any dirt, burrs or scratches.
- Insert the Cassette Seal into the bore using a jig that only makes contact with the metal face of the cassette. Ensure that it does not touch the rubber. Only use a hydraulic piston guided with proper concentricity to the hub. Do not use a hammer or other tool to insert the Cassette Seal.
- The Cassette Seal orientation is indicated by "oil side" or "air side" marked on the seal. Once installed, ensure that the metal face is correctly oriented within the bore.
- Apply pre-lubricating media to the inner rubber surface of the seal. Never use oil or grease as they may reduce the stability of the Cassette Seal on the shaft. If the Cassette Seal is fitted with an optional HRV axial lip, then apply grease to the HRV.
- Insert the shaft or spindle inside the Cassette Seal. The shaft must be driven with proper concentricity to avoid damage. It is recommended to use a hydraulic piston – never use a hammer.

If this procedure is not followed, the Cassette Seal may not function correctly. If this procedure is not possible, contact your local Trelleborg Sealing Solutions marketing company to evaluate alternative assembly procedures.



During the start-up phase with the new Cassette Seal, some leakage of grease and smoke formation may be observed. This is a result of the generation of frictional heat between the metal case and internal rubber support lugs, and does not influence the function and service life of the seal.

When repairing or replacing a Cassette seal, always use a new seal.

SYSTEM 5000

The System 5000 seal must be installed onto a shaft or a sleeve by a special assembly tool. The seal shall be oriented with the side marked "oil side" facing the inside of the gearbox. The shaft must then be assembled so the oil side of the seal is entering the housing bore.

If the shaft is hollow, the assembly tool should be designed with a guiding column.

For pinion applications on trucks, when a separate end carrier is used, the seal is simply pressed onto the end carrier in a first step of assembling. The end carrier is then entering the splines on the pinion shaft and then a locking nut is used to drive the end carrier and the seal into the right position.

The force required to assemble a System 5000 seal onto the shaft is between 20 to 50 kN, while assembly into the housing bore requires about 1.0 kN. The value of assembly force depends on the surface structure for shaft respecting the housing bore as well as the tolerances. It is recommended to oil the outer rubber covered surface of the seal and also the housing bore, to decrease the force necessary for assembly.

During the start-up phase, eventually some leakage of grease and smoke formation may occur. This is a result of the generation of frictional heat between the metal cases and the support lugs of rubber, and does not influence on the function and service life of the seal.

If the seal is jammed or damaged in some way during installation, the seal must be replaced before start up.

If the construction is disassembled for any reason, a new seal should be installed.

Further instructions for assembling can be found on separate assembly instruction sheets available from your local Trelleborg Sealing Solutions marketing company.

DISMANTLING AND REPLACEMENT

As all the necessary functions are integrated in the Cassette Seal the complete sealing arrangement is renewed. The shaft to be sealed is unaffected by wear and once it has been cleaned and possible corrosion and dirt have been removed a new seal can be fitted again.

The Cassette Seal may be provided with a sealant on the metal casing when it is installed into the housing. Take care that the sealant does not flow into the seal or is smeared onto the rubber surface, as this may impede the function of the seal. The sealant can reduce the risk of static leakage due to small imperfections on the surface.

STORAGE

As the service life of bearings and other machine parts depends on how well the seals perform, seals should be handled with caution. Unfavorable storage conditions or improper handling will most likely lead to a change of their physical properties. This can lead to a shortening of life, or failure, for example as a result of hardening or softening, cracking or other surface damages. These changes can be the result of one particular factor or a combination of factors, like oxygen, ozone, heat, light, moisture, solvents etc. Storing the seals under load can lead to permanent deformation of the elastomer. On the other hand, properly stored elastomer products retain their properties for several years.

As the sensitive sealing lips and counter faces are well protected inside the Cassette Seal casing, there is less risk of mechanical damages and influence of dirt and dust in comparison to many other seal types.

CLEANING

If cleaning of Cassette Seal is necessary, use a damp duster and allow the seals to dry off at room temperature.

Solvents, sharp-edged objects and abrasives should not be used.



■ Type APJ – Combined Oil Seal

GENERAL DESCRIPTION

The APJ seal is an assembly composed of a rotary oil seal and a wear sleeve; the rotary oil seal is designed to satisfy the customer specifications in terms of shaft speed, pressure, temperature, axial play and chemical compatibility and usually includes supplementary labyrinths and grease packing to prevent contaminant ingress. The integrated wear sleeve has a surface mating with the rotary oil seal, that is properly machined by Trelleborg, removing the need for shaft hardening and grinding. The sleeve can be rubberized or provided by a static sealing coating on the interface with the shaft.

APPLICATION EXAMPLES

- Off-road wheel hubs
- Industrial transmissions
- Robot gearboxes
- Food and chemical mixers

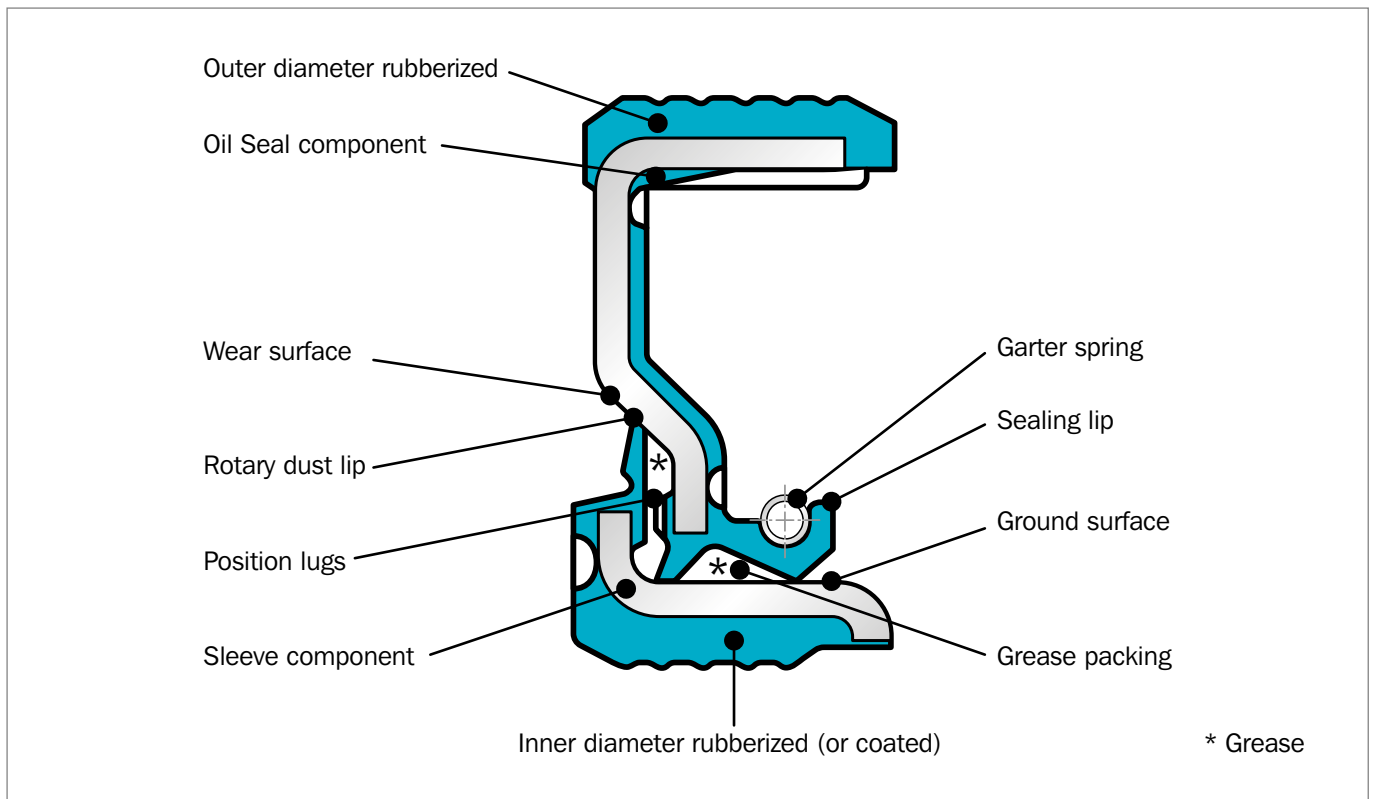

Figure 59: APJ Seal



SPECIAL FEATURES

- The overall geometry of the sealing component and the sleeve are tailored to fit the available space and the required assembly procedure.
- The APJ is delivered assembled, and pre-packed with grease
- The APJ can usually be assembled in the application in two ways, depending on its design and the application design; it can be fitted as a unique component in the bore and in the shaft, or it can be disassembled by the customer, and then the oil seal fitted in the bore and the sleeve on the shaft, providing minimized internal friction.
- According to the type and to the amount of external contaminants, the APJ is designed with a tailored protection by one or more elastomeric dust lips, having an optimized geometry that can withstand the axial and radial misplacements and generate an effective sealing labyrinth.
- The static sealing between sleeve and shaft can be warranted by a rubber layer, or by a coating sealant; this last design requires less radial space, and provides an optimized dissipation of the heat generated by the sealing lip sliding.

MATERIALS AND CHEMICAL COMPATIBILITY

APJ combined Rotary Oil Seals are designed according to customer specifications, so they can benefit from the broad range of Trelleborg Sealing Solutions elastomeric compounds and any metal required in terms of working temperatures and chemical compatibility.

- The Rotary Oil Seal component can be made from proprietary compounds suitable for ROS, for example FDA grades of FPM and EPDM, high temperature and high oil compatibility FKM-XploR, HNBR and NBR, very low temperatures FVMQ and FKM, able to work up to -60°C
- The materials of the metal inserts and of the energizing spring are selected between carbon steel and several grades of stainless steels, according to working environment (for example if there are FDA requirements, or chemical exposure)
- The type of grease used for internal packing is selected according to working conditions; FDA grade is available

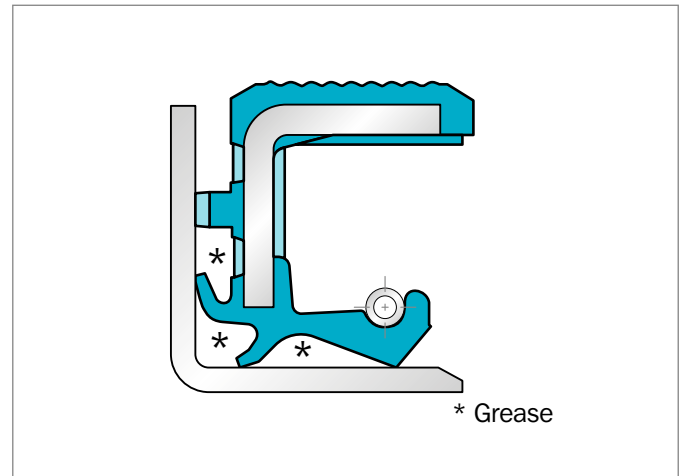

Figure 60: APJ for corrosive applications

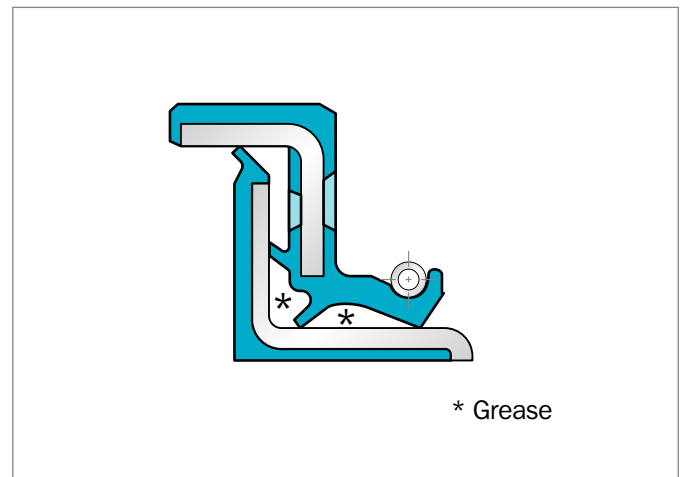

Figure 61: "Hygienic design" APJ for food applications

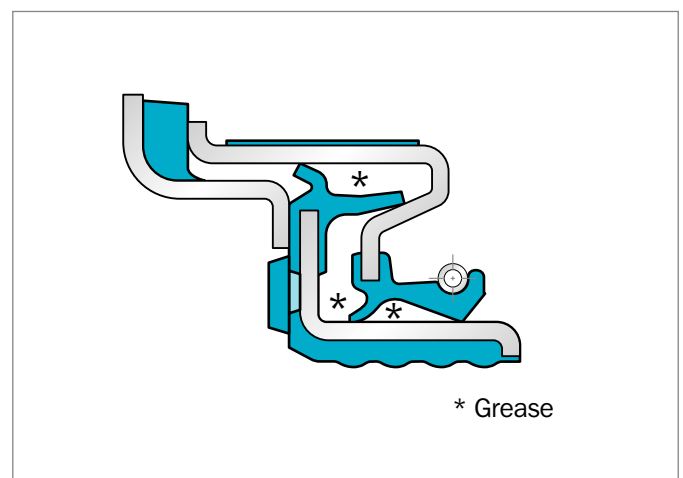

Figure 62: APJ for heavy polluted applications and axial play of the shaft



End Covers







■ End Covers

■ General Description

End covers are components to be fitted in the housing bores where no input/output shaft is located. Moreover they are used to plug and seal service bores. Standard end covers are manufactured in accordance with bore tolerances recommended by DIN 3760 and ISO 6194/1 for radial oil seals.

Two different types of end covers are available as described in the following chapters. The type YJ38 is fully rubber covered and the type YJ39 has a "half-half" design.

■ Type YJ 38

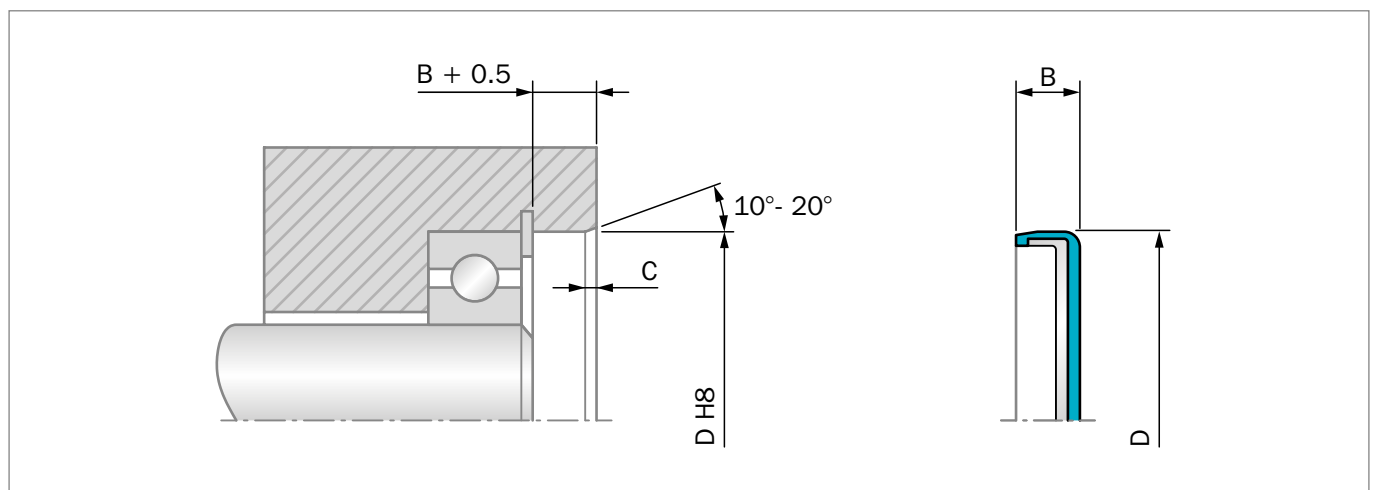

Figure 63: Installation Drawing

ADVANTAGES

- Good static sealing
- Compensation of different thermal expansion
- No risk of fretting corrosion
- Effective protection against air side contaminants
- Higher bore surface roughness is allowed
- Mounting in split-housings

APPLICATION EXAMPLES

- Transmission systems (e.g. gearboxes)
- Machine tool



OPERATING CONDITIONS

Pressure:	Up to 0.05 MPa
Temperature:	-40 °C to +200 °C depending on material
Media:	Mineral and synthetic lubricants (CLP, HLP, APGL etc.)

Trelleborg Sealing Solutions has carried out several thousands compatibility tests. Please ask for details.

IMPORTANT NOTE

The above data are maximum values and cannot be used at the same time, e. g. the maximum operating speed depends on material type, pressure and temperature.

Table 42: Materials

Standard Material*	TSS Material Code	Standard Metal Insert**
NBR (70 Shore A)	N7MMN	Carbon steel
NBR (75 Shore A)	4N01	Carbon steel
FKM (75 Shore A)	VCBV	Carbon steel
FKM (75 Shore A)	4V01	Carbon steel

* Special grades and other materials (ACM, EACM, EPDM, HNBR, VMQ) on request.

** Metal insert can also be supplied in different materials on request

ORDERING EXAMPLE END COVER TSS TYPE

TSS Type:	YJ
Code:	YJ38
Dimensions:	Housing diameter 50 mm Width 10 mm
Material:	NBR
Material Code:	N7MMN

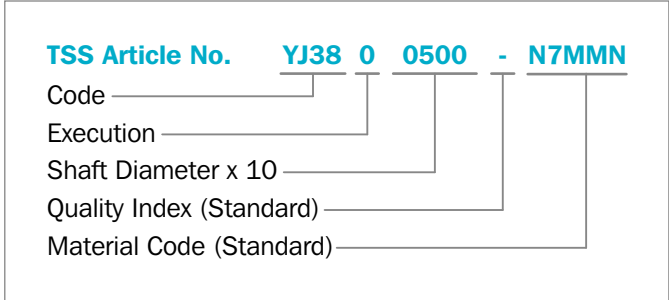

Trelleborg Sealing Solutions has carried out several thousand compatibility tests. Please ask your local Trelleborg Sealing Solutions marketing company for details.



Table 43: Preferred Series/ Dimension, TSS Part Numbers

Bore D H8	Width B	Chamfer C	TSS Part No.	TSS	
				NBR	FKM
10	4	1.0	YJ3800100	●	
16	4	1.0	YJ3800160	●	
19	6	1.3	YJ3810190	●	
20	4	1.0	YJ3800200	●	
22	7	1.3	YJ3800220	●	
24	7	1.3	YJ3800240	●	
25	7	1.3	YJ3800250	●	
26	6.5	1.3	YJ3800260	●	
28	7	1.3	YJ3800280	●	●
28	9	1.5	YJ3810280	●	
30	6	1.3	YJ3810300	●	
30	8	1.5	YJ3800300	●	
32	5	1.0	YJ3820320	●	●
32	7	1.3	YJ3810320	●	
32	9.5	1.5	YJ3800320	●	
35	8	1.5	YJ3800350	●	
37	5	1.0	YJ3810370	●	
37	10	1.8	YJ3800370	●	
40	7	1.3	YJ3800400	●	
42	7	1.3	YJ3810420	●	
42	9.5	1.5	YJ3800420	●	
47	6.5	1.3	YJ3800470	●	●
47	7	1.3	YJ3830470	●	
47	8	1.5	YJ3810470	●	
47	10	1.8	YJ3820470	●	●
50	10	1.8	YJ3800500	●	●
52	6.5	1.3	YJ3800520	●	
52	10	1.8	YJ3810520	●	
55	6	1.3	YJ3820550	●	
55	9	1.5	YJ3800550	●	
55	10	1.8	YJ3810550	●	
60	10	1.8	YJ3800600	●	
62	7	1.3	YJ3820620	●	
62	8	1.5	YJ3800620	●	●
65	10	1.8	YJ3800650	●	
68	8	1.5	YJ3800680	●	
70	10	1.8	YJ3800700	●	
72	9	1.5	YJ3800720	●	●
75	7	1.3	YJ3800750	●	
75	10	1.8	YJ3810750	●	
75	12	2.0	YJ3820750	●	●
80	8	1.5	YJ3800800	●	



Bore	Width	Chamfer	TSS Part No.	TSS	
D H8	B	C		NBR	FKM
80	10	1.8	YJ3820800	●	
80	12	2.0	YJ3830800	●	
85	10	1.8	YJ3810850	●	
85	12	2.0	YJ3800850	●	
90	8	1.5	YJ3800900	●	
90	12	2.0	YJ3810900	●	
95	10	1.8	YJ3800950	●	
100	10	1.8	YJ3811000	●	●
100	12	2.0	YJ3801000	●	●
110	8	1.5	YJ3811100	●	
110	12	2.0	YJ3801100	●	
115	12	2.0	YJ3801150	●	
120	12	2.0	YJ3801200	●	
125	12	2.0	YJ3801250	●	
130	10	1.8	YJ3811300	●	
130	12	2.0	YJ3801300	●	
140	15	2.0	YJ3801400	●	
150	15	2.0	YJ3801500	●	
160	15	2.0	YJ3801600	●	
168	11	1.8	YJ3801680	●	
170	15	2.0	YJ3801700	●	
180	12	2.0	YJ3801800	●	
190	12	2.0	YJ3801900	●	
200	13	2.0	YJ3802000	●	
210	15	2.0	YJ3802100	●	
230	14	2.0	YJ3802300	●	



■ Type YJ 39

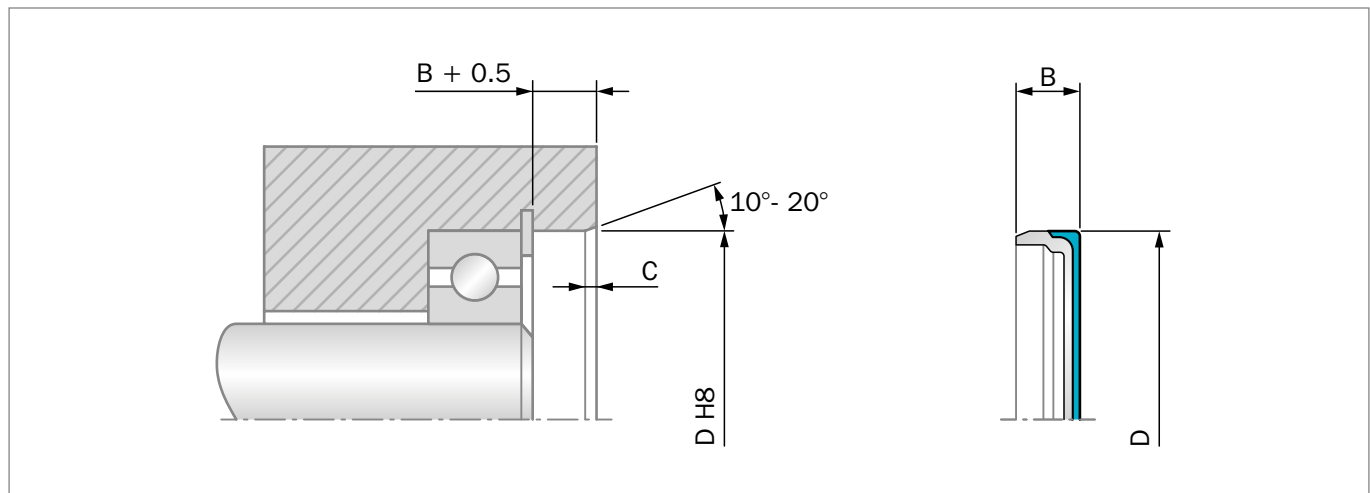

Figure 64: Installation Drawing

ADVANTAGES

- Good static sealing and stiffness (no pop-out effect)
- Compensation of different thermal expansion
- No risk of fretting corrosion
- Effective protection against air side contaminants
- Higher bore surface roughness is allowed
- Mounting in split-housings
- Good heat transfer

APPLICATION EXAMPLES

- Transmission systems (e.g. gearboxes)
- Machine tools

OPERATING CONDITIONS

Pressure:	Up to 0.05 MPa
Temperature:	-40 °C to +200 °C depending on material
Media:	Mineral and synthetic lubricants (CLP, HLP, APGL etc.)

Trelleborg Sealing Solutions has carried out several thousands compatibility tests. Please ask your local Trelleborg Sealing Solutions marketing company for details.

IMPORTANT NOTE

The above data are maximum values and cannot be used at the same time, e. g. the maximum operating speed depends on material type, pressure and temperature.



Table 44: Materials

Standard Material*	TSS Material Code	Standard Metal Insert**
NBR (70 Shore A)	N7MM	Carbon steel

* Special grades and other materials (ACM, EACM, EPDM, HNBR, VMQ) on request.

** Metal insert can also be supplied in different materials on request

ORDERING EXAMPLE END COVER TSS TYPE

TSS Type:	YJ
Code:	YJ39
Dimensions:	Housing diameter 52 mm Width 6 mm
Material:	NBR
Material Code:	N7MM

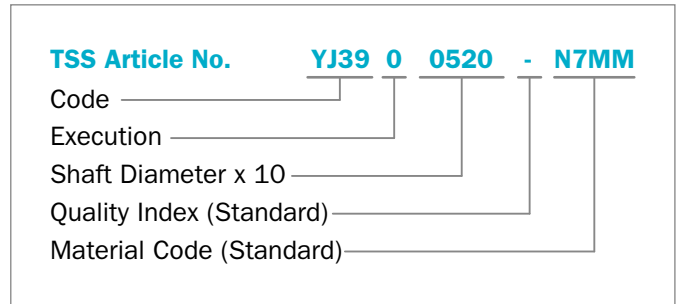

Table 45: Preferred Series / Dimension, TSS Part Numbers

Bore	Width	Chamfer	TSS Part No.	TSS
D H8	B	C		NBR
20	5	1.3	YJ3900200	●
22	7	1.3	YJ3900220	●
25	7	1.3	YJ3900250	●
26	7	1.3	YJ3900260	●
28	7	1.3	YJ3900280	●
35	7	1.3	YJ3900350	●
40	7	1.3	YJ3900400	●
42	7	1.3	YJ3900420	●
47	7	1.3	YJ3900470	●
52	6	1.3	YJ3900520	●
62	8	1.5	YJ3900620	●
65	10	1.8	YJ3900650	●
72	9	1.5	YJ3900720	●
75	8	1.5	YJ3900750	●
80	8	1.5	YJ3900800	●
90	10	1.8	YJ3900900	●
100	10	1.8	YJ3901000	●
100	12	2.0	YJ3911000	●
115	12	2.0	YJ3901150	●
140	15	2.0	YJ3901400	●
145	12	2.0	YJ3901450	●
210	15	2.0	YJ3902100	●

Shaft Repair Kit







■ Shaft Repair Kit

■ General Description

The shaft repair kit serves as a running surface for rotary shaft lip seals. It consists of a thin-walled cylindrical tube with a mounting flange (see Figure 65). The flange has a design breaking point and can – if it is an obstacle – be removed.

The shaft repair kit has a wall thickness of approximately 0.254 mm and a spiral free ground surface. It is ideally suited as a counter face for rotary shaft lip seals.

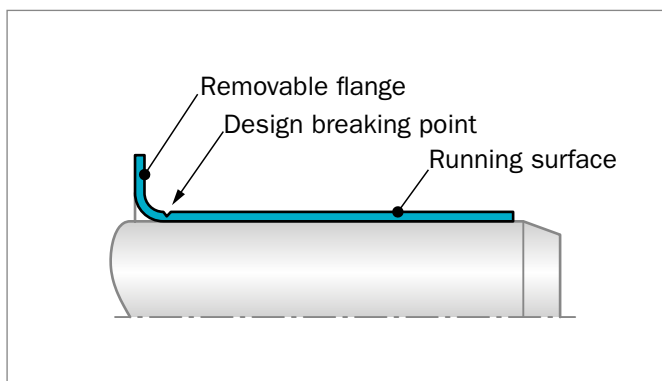

Figure 65: Design of the shaft repair kit

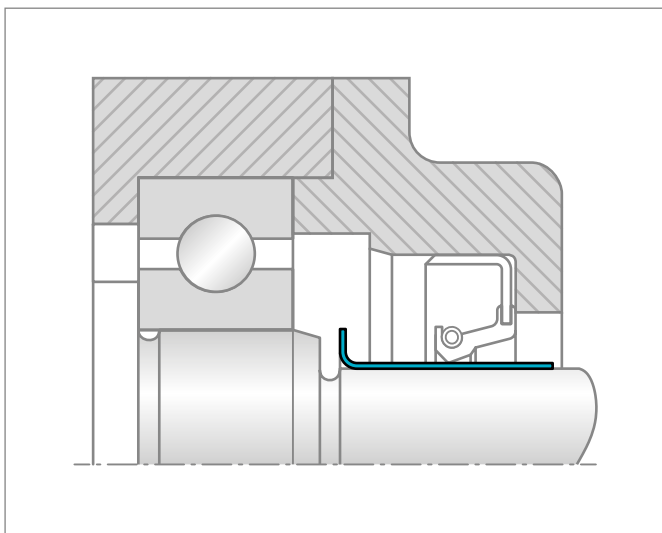

Figure 66: Running surface with shaft repair kit

ADVANTAGES

- Inexpensive replacement of worn shaft surfaces
- Simple and quick installation with supplied assembly tool
- No alterations to the seal dimensions
- Wear-resistant surface for long service life
- Secure seating due to a force fit

APPLICATION EXAMPLES

- Repair of worn shaft surfaces
- Used in new designs to save costs for surface treatment

OPERATING CONDITIONS

Material:	Stainless steel, AISI 304 (1.4301)
------------------	------------------------------------

Material Code:	900 V
-----------------------	-------

Wall thickness:	0.254 mm
------------------------	----------

Surface:	Ground spiral-free ($R_a = 0.25 \dots 0.5 \mu\text{m}$)
-----------------	--

Hardness:	95 HRB
------------------	--------



INSTALLATION INSTRUCTIONS

The shaft repair kit is fitted using the installation tool supplied. The raised mounting flange and the tool supplied ensure an exact fit.

Together they prevent tilting during installation and thus damage to the sealing surface.

Observe the following points before installation:

- Remove dust, dirt, rust, etc. from the damaged running surface
- Repair deep running scores with filling compound, e.g. metal-filled synthetic resin
- Check that the shaft has a lead-in chamfer

INSTALLATION SEQUENCE

- Check the nominal diameter of the shaft. The oversize to the nominal dimension of the shaft must be taken into consideration
- Place the shaft repair kit with the mounting flange facing forward onto the shaft
- Push on the installation tool
- Push on the shaft repair kit by striking the installation tool with a hammer or use a press
- If necessary, cut the mounting flange using side cutters up to the design breaking point and break off the flange at the line
- Grease the shaft repair kit before fitting the seal

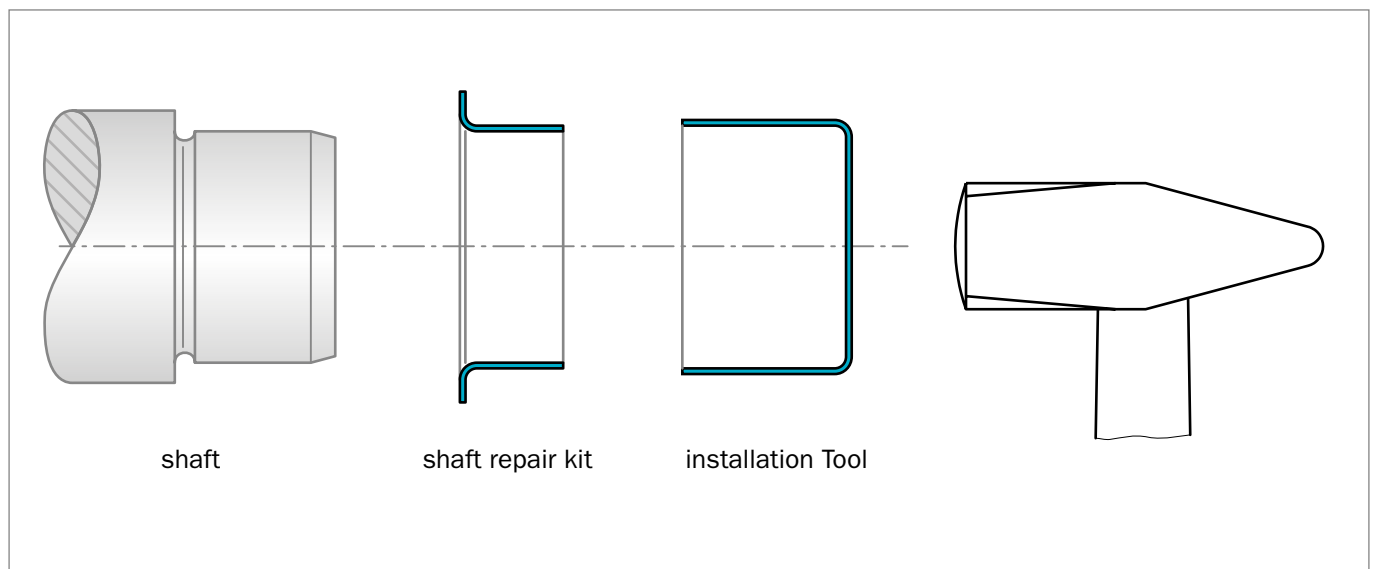

Figure 67: Installation sequence



■ Installation Recommendation – Metric Sizes

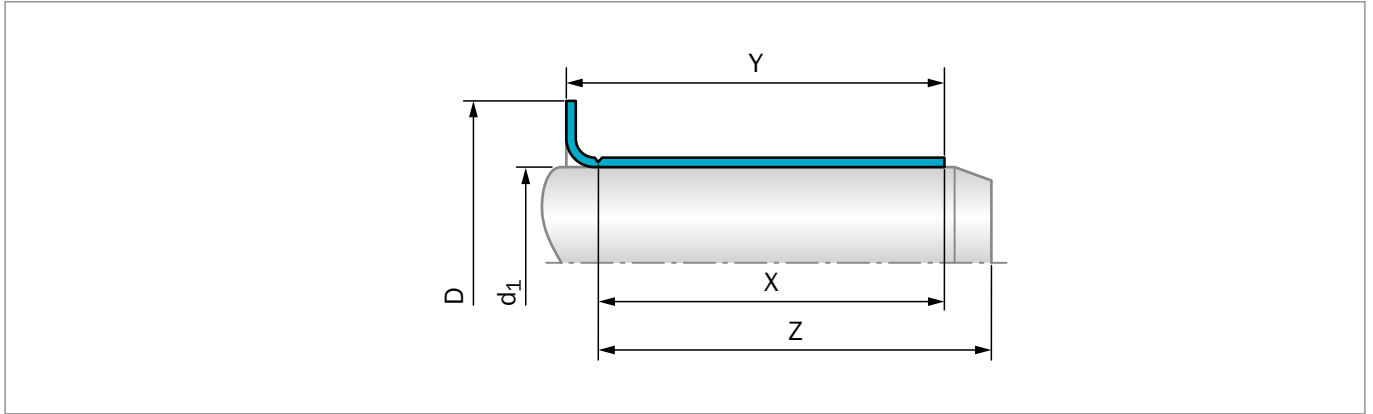

Figure 68: Installation Drawing

Table 46: Installation Dimensions – Metric

Shaft Diameter Metric Sizes			Length without Flange	Overall Length	Flange Diameter	Max. Installation Depth	TSS Article No.
Nominal Dia.	Range						
d_1	min.	max.	$X \pm 0.8$	$Y \pm 0.8$	$D \pm 1.6$	Z	
12.0	11.93	12.07	6.0	8.4	20.0	12.0	TS0099049-900V
15.0	14.96	15.06	5.0	9.0	19.1	11.0	TS0099059-900V
17.0	16.94	17.04	8.0	11.0	22.2	51.0	TS0099068-900V
18.0	17.89	18.00	8.0	11.0	27.0	46.0	TS0099082-900V
20.0	19.94	20.04	8.0	11.0	23.6	51.0	TS0099078-900V
22.0	21.87	22.00	8.0	12.0	30.2	46.0	TS0099085-900V
25.0	24.94	25.04	8.0	11.0	33.0	51.0	TS0099098-900V
26.0	25.87	26.00	8.0	12.0	33.3	46.0	TS0099103-900V
28.0	27.94	28.04	9.5	12.7	34.9	71.0	TS0099111-900V
30.0	29.95	30.07	8.0	11.0	35.6	17.0	TS0099114-900V
32.0	31.93	32.08	8.0	11.1	38.0	18.0	TS0099128-900V
35.0	34.93	35.08	13.0	16.0	41.6	20.0	TS0099139-900V
36.0	35.84	36.00	13.0	17.0	42.9	25.0	TS0099146-900V
38.0	37.84	38.00	13.0	17.0	45.2	25.0	TS0099147-900V
40.0	39.93	40.08	13.0	16.0	47.0	26.0	TS0099157-900V
42.0	41.86	42.00	14.3	17.5	53.0	21.0	TS0099169-900V
45.0	44.93	45.09	14.0	17.0	53.0	21.0	TS0099177-900V
48.0	47.92	48.08	14.0	17.0	56.0	25.0	TS0099189-900V
50.0	49.91	50.06	14.0	17.0	57.0	25.0	TS0099196-900V
55.0	54.91	55.07	20.0	23.0	62.0	32.0	TS0099215-900V
60.0	59.92	60.07	20.0	23.0	70.7	35.0	TS0099235-900V
62.0	61.85	62.00	12.7	15.9	71.8	36.0	TS0099242-900V
65.0	64.92	65.07	20.0	23.0	72.4	35.0	TS0099254-900V
70.0	69.85	70.00	10.3	14.3	79.4	31.0	TS0099272-900V



Shaft Diameter Metric Sizes			Length without Flange	Overall Length	Flange Diameter	Max. Installation Depth	TSS Article No.
Nominal Dia.	Range						
d₁	min.	max.	X ± 0.8	Y ± 0.8	D ± 1.6	Z	
70.0	69.93	70.08	20.0	24.0	79.4	32.0	TS0099276-900V
75.0	74.93	75.08	22.0	26.0	84.0	33.0	TS0099294-900V
80.0	79.81	80.01	19.1	22.5	89.9	35.0	TS0099313-900V
80.0	79.91	80.09	21.0	24.0	90.0	35.0	TS0099315-900V
85.0	84.78	85.00	21.0	25.0	94.0	35.0	TS0099333-900V
90.0	89.92	90.07	23.0	28.0	101.6	44.0	TS0099354-900V
95.0	94.92	95.07	21.0	24.0	102.2	44.0	TS0099369-900V
100.0	99.85	100.10	20.6	25.4	110.0	52.0	TS0099393-900V
105.0	104.90	105.11	20.0	23.0	113.5	35.0	TS0099413-900V
110.0	109.90	110.10	12.9	16.5	125.0	31.0	TS0099435-900V
115.0	114.88	115.09	20.6	23.8	127.0	32.0	TS0099452-900V
120.0	119.89	120.09	20.0	25.0	129.8	32.0	TS0099473-900V
125.0	124.89	125.10	26.0	32.0	137.2	37.0	TS0099492-900V
130.0	129.98	130.18	22.0	25.3	139.5	33.0	TS0099491-900V
135.0	134.79	135.00	20.5	25.4	149.2	32.0	TS0099533-900V
140.0	139.90	140.11	20.5	25.5	151.0	32.0	TS0099552-900V
150.0	149.75	150.00	26.0	30.0	159.0	34.0	TS0099595-900V
155.0	154.75	155.00	26.0	30.0	167.0	33.0	TS0099606-900V
160.0	159.97	160.23	25.4	31.8	177.8	46.0	TS0099630-900V
165.0	164.97	165.23	25.4	31.8	177.8	44.0	TS0099650-900V
170.0	169.75	170.00	31.8	38.0	182.6	55.0	TS0099640-900V
175.0	174.75	175.00	28.0	32.0	187.0	35.0	TS0099687-900V
180.0	179.76	180.00	33.0	38.0	190.5	45.0	TS0099721-900V
185.0	184.73	185.00	32.0	38.0	199.0	55.0	TS0099726-900V
200.0	199.87	200.13	34.5	38.1	212.7	44.0	TS0099787-900V



■ Installation Recommendation – Inch Sizes

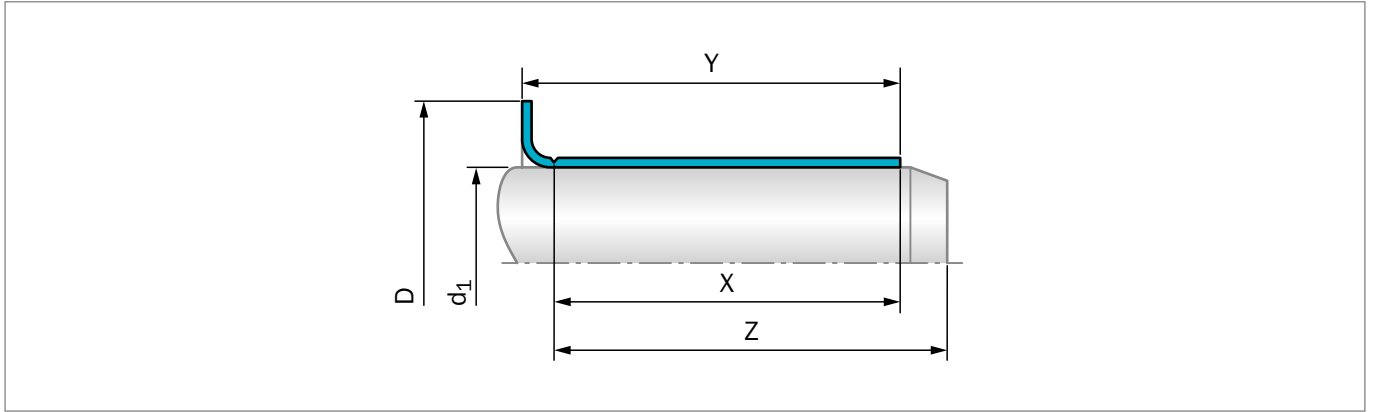

Figure 69: Installation Drawing

Table 47: Installation Dimensions – Inch

Shaft Diameter inch Sizes			Length without Flange	Overall Length	Flange Diameter	Max. Installation Depth	TSS Article No.
Nominal Dia.	Range						
d_1	min.	max.	$X \pm 0.031$	$Y \pm 0.031$	$D \pm 0.063$	Z	
0.500	0.498	0.502	0.250	0.344	0.610	2.000	TS0099050-900V
0.563	0.560	0.566	0.250	0.391	0.750	1.831	TS0099056-900V
0.625	0.623	0.627	0.313	0.406	0.750	2.000	TS0099062-900V
0.750	0.748	0.752	0.313	0.438	0.945	2.000	TS0099076-900V
0.781	0.780	0.784	0.313	0.438	0.935	2.000	TS0099080-900V
0.859	0.857	0.861	0.250	0.373	1.155	2.000	TS0099086-900V
0.875	0.873	0.877	0.313	0.438	1.094	2.000	TS0099087-900V
0.969	0.966	0.970	0.313	0.438	1.130	2.000	TS0099094-900V
0.969	0.966	0.970	0.625	0.719	1.130	2.000	TS0099096-900V
1.000	0.998	1.002	0.313	0.438	1.219	2.000	TS0099100-900V
1.063	1.060	1.064	0.313	0.438	1.320	2.813	TS0099106-900V
1.125	1.123	1.127	0.313	0.438	1.500	0.688	TS0099112-900V
1.156	1.154	1.158	0.375	0.500	1.350	0.688	TS0099120-900V
1.188	1.185	1.190	0.313	0.438	1.400	0.688	TS0099118-900V
1.240	1.237	1.243	0.315	0.438	1.540	0.688	TS0099141-900V
1.250	1.247	1.253	0.313	0.438	1.500	0.688	TS0099125-900V
1.313	1.308	1.314	0.250	0.375	1.600	0.813	TS0099129-900V
1.313	1.310	1.316	0.500	0.625	1.594	1.813	TS0099131-900V
1.375	1.371	1.377	0.313	0.438	1.638	0.813	TS0099133-900V
1.375	1.371	1.377	0.500	0.625	1.638	0.813	TS0099138-900V
1.438	1.432	1.438	0.563	0.688	1.690	1.016	TS0099143-900V
1.438	1.435	1.441	0.375	0.500	1.781	1.016	TS0099144-900V
1.500	1.497	1.503	0.563	0.688	1.781	1.016	TS0099149-900V
1.500	1.497	1.503	0.375	0.500	1.781	1.016	TS0099150-900V



Shaft Diameter inch Sizes			Length without Flange	Overall Length	Flange Diameter	Max. Installation Depth	TSS Article No.
Nominal Dia.	Range						
d ₁	min.	max.	X ± 0.031	Y ± 0.031	D ± 0.063	Z	
1.563	1.559	1.565	0.563	0.688	1.859	1.016	TS0099156-900V
1.625	1.622	1.628	0.313	0.438	1.875	1.016	TS0099161-900V
1.625	1.623	1.628	0.563	0.688	1.875	0.813	TS0099162-900V
1.688	1.685	1.691	0.313	0.438	1.906	0.875	TS0099167-900V
1.688	1.684	1.690	0.563	0.688	1.906	0.875	TS0099168-900V
1.719	1.715	1.721	0.563	0.688	2.031	0.813	TS0099171-900V
1.750	1.747	1.753	0.375	0.500	2.055	0.813	TS0099172-900V
1.750	1.747	1.753	0.563	0.688	2.063	0.813	TS0099174-900V
1.750	1.747	1.753	0.750	0.875	2.063	0.813	TS0099175-900V
1.750	1.747	1.753	0.531	0.625	2.063	0.812	TS0099180-900V
1.781	1.778	1.784	0.664	0.800	2.125	1.125	TS0099179-900V
1.875	1.872	1.878	0.375	0.516	2.203	1.050	TS0099184-900V
1.875	1.872	1.878	0.563	0.688	2.203	1.000	TS0099187-900V
1.875	1.872	1.878	0.295	0.415	2.203	0.744	TS0099188-900V
1.875	1.872	1.878	0.175	0.295	2.203	0.744	TS0099190-900V
1.938	1.934	1.940	0.563	0.688	2.219	1.000	TS0099193-900V
1.969	1.965	1.971	0.551	0.688	2.244	0.984	TS0099196-900V
2.000	1.997	2.003	0.563	0.688	2.406	1.050	TS0099199-900V
2.000	1.997	2.003	0.875	1.000	2.406	1.000	TS0099200-900V
2.063	2.057	2.063	0.781	0.938	2.469	1.375	TS0099205-900V
2.125	2.123	2.128	0.500	0.750	2.422	1.281	TS0099210-900V
2.125	2.124	2.130	0.781	0.938	2.422	1.375	TS0099212-900V
2.188	2.186	2.192	0.781	0.938	2.500	1.313	TS0099218-900V
2.250	2.249	2.255	0.781	0.938	2.531	1.313	TS0099225-900V
2.250	2.249	2.255	0.313	0.438	2.531	1.313	TS0099227-900V
2.313	2.309	3.315	0.781	0.938	2.688	1.375	TS0099231-900V
2.375	2.369	2.375	0.781	0.938	2.750	1.375	TS0099236-900V
2.375	2.374	2.380	0.781	0.938	2.750	1.375	TS0099237-900V
2.375	2.372	2.378	0.594	0.750	2.750	1.375	TS0099238-900V
2.375	2.374	2.380	0.526	0.683	2.750	1.375	TS0099240-900V
2.438	2.435	2.441	0.500	0.625	2.828	1.425	TS0099242-900V
2.438	2.434	2.440	0.781	0.938	2.828	1.375	TS0099243-900V
2.500	2.500	2.506	0.500	0.656	2.828	1.393	TS0099248-900V
2.500	2.500	2.506	0.781	0.938	2.820	1.375	TS0099250-900V
2.563	2.560	2.566	0.781	0.938	2.850	1.375	TS0099256-900V
2.625	2.622	2.628	0.500	0.625	3.047	1.375	TS0099260-900V
2.625	2.621	2.627	0.781	0.938	3.047	1.375	TS0099262-900V
2.625	2.621	2.627	0.781	0.906	3.047	1.562	TS0099264-900V
2.750	2.747	2.753	1.438	1.625	3.075	1.625	TS0099267-900V
2.750	2.750	2.756	1.125	1.250	3.125	1.313	TS0099269-900V
2.750	2.747	2.753	0.781	0.906	3.125	1.250	TS0099270-900V
2.750	2.750	2.756	0.406	0.563	3.125	1.250	TS0099272-900V



Shaft Diameter inch Sizes			Length without Flange	Overall Length	Flange Diameter	Max. Installation Depth	TSS Article No.
Nominal Dia.	Range						
d ₁	min.	max.	X ± 0.031	Y ± 0.031	D ± 0.063	Z	
2.750	2.745	2.751	0.781	0.938	3.125	1.250	TS0099274-900V
2.750	2.750	2.756	0.781	0.938	3.125	1.250	TS0099275-900V
2.813	2.809	2.815	0.594	0.688	3.188	1.250	TS0099281-900V
2.875	2.873	2.879	0.781	0.938	3.219	1.250	TS0099287-900V
2.938	2.937	2.943	0.781	0.938	3.344	1.250	TS0099293-900V
3.000	2.997	3.003	0.813	0.938	3.240	1.375	TS0099296-900V
3.000	3.000	3.006	0.813	1.000	3.235	1.281	TS0099300-900V
3.000	3.000	3.006	0.625	0.813	3.345	1.063	TS0099303-900V
3.125	3.124	3.132	0.551	0.709	3.525	2.031	TS0099307-900V
3.125	3.120	3.126	0.688	0.813	3.531	2.000	TS0099311-900V
3.125	3.120	3.126	0.813	1.000	3.531	2.000	TS0099312-900V
3.250	3.247	3.253	0.813	1.000	3.594	1.375	TS0099322-900V
3.250	3.250	3.256	0.595	0.719	3.575	1.375	TS0099324-900V
3.250	3.250	3.256	0.813	1.000	3.585	1.375	TS0099325-900V
3.375	3.373	3.379	0.813	1.000	3.695	1.375	TS0099337-900V
3.375	3.373	3.379	0.375	0.500	3.688	1.410	TS0099338-900V
3.438	3.435	3.441	0.781	0.906	3.844	1.406	TS0099339-900V
3.500	3.500	3.506	0.313	0.500	3.825	1.347	TS0099347-900V
3.500	3.500	3.506	0.813	1.000	3.844	1.347	TS0099350-900V
3.563	3.560	3.566	0.813	1.000	3.900	1.750	TS0099356-900V
3.625	3.623	3.629	0.813	1.000	4.031	1.750	TS0099362-900V
3.625	3.623	3.629	0.500	0.625	4.025	1.750	TS0099363-900V
3.688	3.685	3.691	0.813	0.938	4.025	1.750	TS0099365-900V
3.688	3.684	3.690	0.313	0.438	3.830	0.875	TS0099368-900V
3.750	3.750	3.756	0.344	0.500	4.025	1.750	TS0099367-900V
3.750	3.750	3.756	0.688	0.875	4.020	1.875	TS0099372-900V
3.750	3.746	3.752	0.563	0.688	4.025	1.750	TS0099376-900V
3.875	3.873	3.879	0.813	1.000	4.219	1.875	TS0099387-900V
4.000	3.398	4.006	0.600	0.725	4.375	2.050	TS0099395-900V
4.000	3.398	4.006	0.813	1.000	4.375	2.050	TS0099399-900V
4.000	3.398	4.006	0.650	0.775	4.375	1.375	TS0099400-900V
4.000	3.398	4.006	0.500	0.625	4.375	1.375	TS0099401-900V
4.125	4.122	4.130	0.813	1.000	4.420	1.375	TS0099412-900V
4.188	4.183	4.191	0.813	1.000	4.500	1.375	TS0099418-900V
4.234	4.226	4.234	0.781	0.906	4.610	1.438	TS0099423-900V
4.250	4.248	4.256	0.813	1.000	4.610	1.438	TS0099424-900V
4.328	4.327	4.335	0.509	0.650	4.921	1.250	TS0099435-900V
4.375	4.370	4.378	0.813	1.000	4.750	1.650	TS0099437-900V
4.406	4.401	4.409	0.748	0.886	4.750	1.063	TS0099438-900V
4.438	4.434	4.442	1.000	1.142	4.813	1.313	TS0099439-900V
4.500	4.496	4.504	0.813	1.000	4.900	1.250	TS0099450-900V
4.625	4.621	4.629	1.000	1.250	5.063	1.375	TS0099463-900V



Shaft Diameter inch Sizes			Length without Flange	Overall Length	Flange Diameter	Max. Installation Depth	TSS Article No.
Nominal Dia.	Range						
d ₁	min.	max.	X ± 0.031	Y ± 0.031	D ± 0.063	Z	
4.625	4.621	4.628	0.438	0.625	4.875	1.375	TS0099465-900V
4.688	4.685	4.693	0.813	1.000	5.063	1.375	TS0099468-900V
4.750	4.746	4.754	0.500	0.750	5.000	1.500	TS0099475-900V
4.875	4.871	4.879	0.625	0.750	5.250	1.438	TS0099487-900V
5.125	5.117	5.125	0.866	0.996	5.493	1.280	TS0099491-900V
5.125	5.120	5.128	0.813	1.000	5.500	1.250	TS0099513-900V
5.250	5.246	5.254	0.813	1.000	5.560	1.250	TS0099525-900V
5.313	5.307	5.315	0.807	1.000	5.875	1.250	TS0099533-900V
5.375	5.371	5.379	0.813	1.000	5.875	1.250	TS0099537-900V
5.438	5.434	5.442	1.500	1.688	5.750	1.875	TS0099548-900V
5.500	5.498	5.506	0.813	1.000	5.938	1.250	TS0099549-900V
5.750	5.746	5.754	0.813	1.000	6.180	1.750	TS0099575-900V
6.000	5.995	6.003	1.000	1.250	6.375	1.750	TS0099599-900V
6.000	5.995	6.003	0.500	0.750	6.360	1.750	TS0099601-900V
6.063	6.058	6.068	1.024	1.181	6.375	1.299	TS0099605-900V
6.203	6.198	6.208	0.813	1.063	6.625	1.750	TS0099620-900V
6.250	6.245	6.255	1.031	1.250	6.625	1.750	TS0099625-900V
6.500	6.495	6.505	1.000	1.250	7.000	1.750	TS0099650-900V
6.688	6.683	6.693	1.250	1.496	7.188	2.175	TS0099640-900V
6.750	6.745	6.755	0.813	1.063	7.175	1.750	TS0099675-900V
6.688	6.683	6.693	1.250	1.496	7.188	2.175	TS0099640-900V
6.750	6.745	6.755	0.813	1.063	7.175	1.750	TS0099675-900V
7.000	6.995	7.005	1.000	1.250	7.475	1.688	TS0099700-900V
7.250	7.244	7.254	1.250	1.500	7.760	2.175	TS0099725-900V
7.500	7.495	7.505	0.813	1.000	7.875	1.250	TS0099750-900V
7.750	7.745	7.755	1.000	1.313	8.270	1.875	TS0099775-900V
7.875	7.869	7.879	1.359	1.500	8.375	1.750	TS0099787-900V
8.000	7.795	8.005	1.000	1.250	8.375	1.750	TS0099800-900V

Forsheda® V-Ring







■ Forsheda® V-Ring

■ General Description

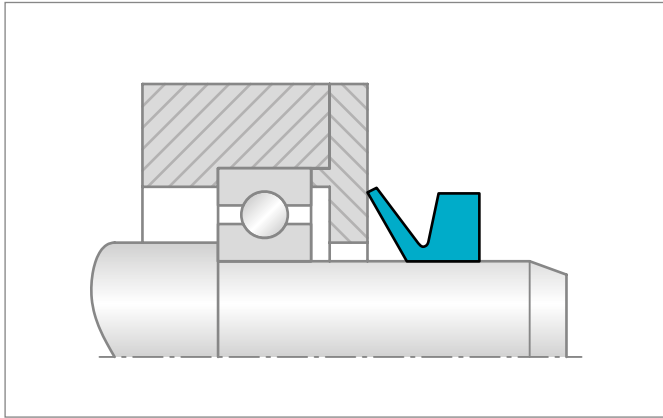

Figure 70: Method of operation of the V-Ring

The V-Ring is a unique all-rubber seal for rotary shafts. Developed in the 1960's by Forsheda AB, it has been used successfully by OEMs and on the replacement market world wide in a broad range of applications.

The V-Ring is the perfect seal to prevent the ingress of dirt, dust, water or combinations of these media while positively retaining grease. With its unique design and performance the V-Ring can be used with a wide range of bearing types. It can also be used as a secondary seal to protect primary seals that do not perform well in hostile environments.

DESCRIPTION AND ADVANTAGES

The V-Ring is normally stretched and mounted directly on the shaft, where it is held in position by the inherent tension of the rubber body. It rotates with the shaft and seals axially against a stationary counterface, perpendicular to the shaft. The counterface can be the side wall of a bearing or a washer, stamping, bearing housing, or even the metal case of an oil seal. The sealing lip is flexible and applies only a relatively light contact pressure against the counter-face and yet is still sufficient to maintain the sealing function. The low contact pressure (that varies with the fitted width) allows the seal to run dry in many applications.

Due to influence of the centrifugal force, the contact pressure of the lip decreases with increased speed. This means that frictional losses and heat are kept to a minimum, resulting in excellent wear characteristics and extended seal life. Once breakaway friction is overcome, the friction reduces steadily until around the 10 - 15 m/s range, when it reduces quite quickly. In the 15 - 20 m/s range the friction reduces to zero. The V-Ring then serves as a clearance seal and deflector. The power loss due to seal friction develops as shown in Figure 71.

The flexible lip and hinge allow the V-Ring to function even in the presence of a certain amount of run-out, eccentricity and shaft misalignment. Contact our local Trelleborg Sealing Solutions marketing company for advice on these and other application issues.

V-Rings are made entirely of rubber without fabric or sheet metal reinforcement. They are, therefore, particularly easy to install. V-Rings can be stretched and, depending on size, installed over flanges, pulleys and bearing housings without costly dismantling. For larger sizes they can even be supplied as cut rings and joined by vulcanization on site.

DESIGN

V-Rings are available in seven standard cross-sections to meet various space and application requirements.

The cross-sections of profiles A and S increase with the shaft diameter, whilst the other types have the same cross-section for the whole diameter range.

Profile A is the most common and available for shaft diameters from 2.7 to 2020 mm, inclusive.

Profile S is wide and tapered, which provides a very firm hold on the shaft. The rings are available for shaft diameters from 4.5 to 210 mm.

Profiles L and LX have narrow axial cross sections making them suitable for compact arrangements and are often used in combination with labyrinth seals. Available for shaft diameters from 105 (135 for LX) to 2025 mm.

Profiles RME, RM and AX are heavy duty V-Rings that are designed primarily for large high speed bearing arrangements, i.e. rolling mill and papermaking machine applications. Additionally they can be used as secondary seals for heavy duty applications where the primary seal has to be protected against water and or particulate contamination. The RME, RM and AX types can be axially and radially located on the shaft with specially designed clamping bands (see page 156). Available for shaft diameters from 300 mm and up.

Larger V-Ring sizes are available as joined seals. For more details please contact your local Trelleborg Sealing Solutions marketing company.

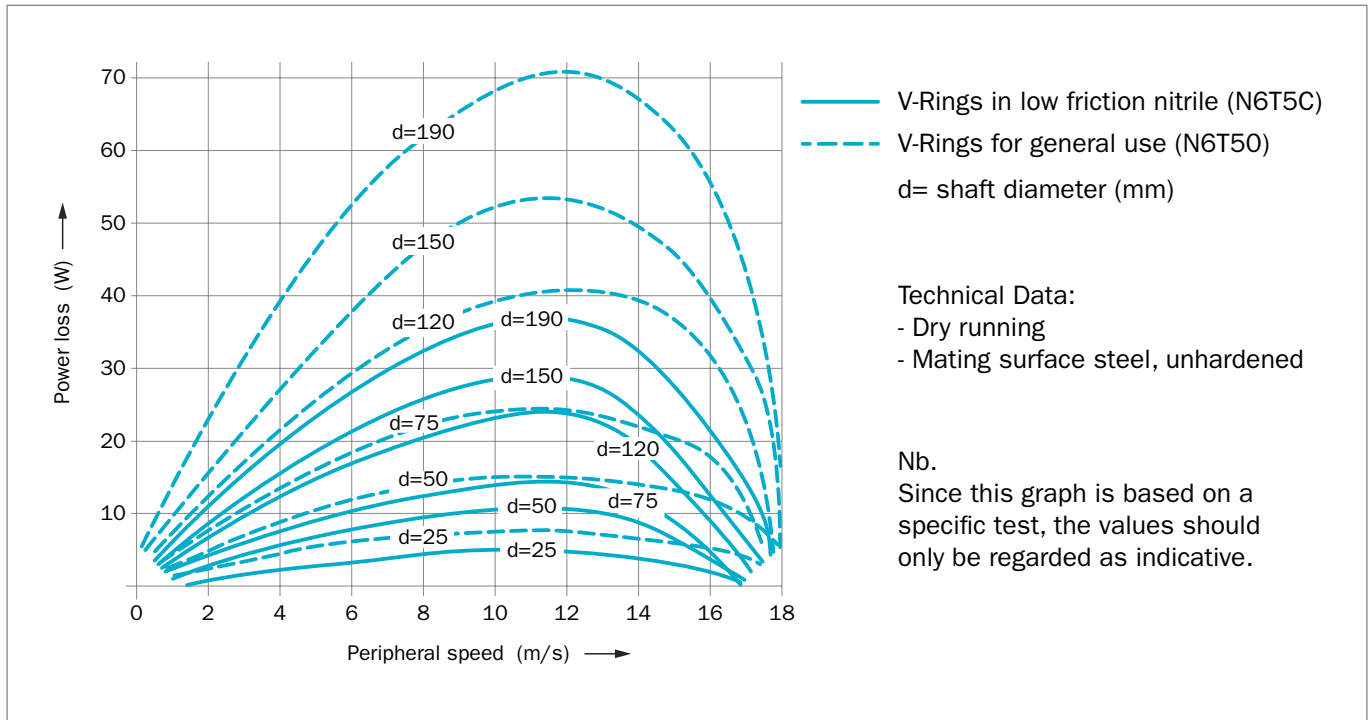

Figure 71: Power loss as a function of peripheral speed for various sizes

Materials

When selecting the correct rubber compound it is necessary to take the following requirements into account:

- good chemical resistance
- good resistance to high and low temperatures
- good resistance to ozone and weathering

It is also necessary to consider the need for the following attributes:

- high resistance to wear
- low friction
- low compression set
- good elasticity

MATERIAL TYPES

The most frequently selected material is the purpose made Nitrile rubber N6T50 which has excellent all round properties.

For applications with temperatures above 100 °C, or in chemically aggressive conditions, V-Rings made of fluorinated rubber (FKM) can be supplied. In fact, a wide range of rubber compounds are available and some of these are listed below.

Table 48: Guide to Selection of Rubber Material

TSS Code	Old Code	Type of Rubber	Characteristics
N6T50	NBR 510	Nitrile	For general use
N6T5C	NBR 562	Nitrile	Low friction
N7T50	NBR 555	Nitrile	Heavy duty conditions. Good tear and abrasion resistance
H7T50	HNBR 576	Hydrogenated Nitrile	Hypoid oils at high temp.
CDT50	CR 415	Chloroprene	For applications in the presence of ozone
E7T50	EPDM 762	Ethylene-Propylene	Good weather and ozone resistance, used with special chemicals such as acetone, ammonium carbonate and benzaldehyde
VDT50	FKM 900	Fluorinated	Very high temperature and chemical resistance
VDT51	FKM 907	Fluorinated	Very high temperature, chemical and wear resistance

Materials highlighted in blue - recommended materials.



TEMPERATURE RESISTANCE

Exposure to higher temperatures accelerate the aging of rubber, the elongation decreases, the compression set increases and finally the material becomes hard and brittle. Cracks at the sealing edge are a typical indication that the seal has been exposed to excessively high temperature. The aging of the rubber has an appreciable negative influence on the useful life of the seal.

The temperature limits for the principal materials are illustrated in Figure 72. They should only be regarded as approximate, since the media and time of exposure also affect the materials.

The temperature ranges within the shaded areas indicate temperatures that can be allowed for only certain periods of time. The higher the temperature, the shorter the service life. If the maximum temperature is exceeded, the elastomer may suffer permanent set or damage. Special elastomers are available for use in cold temperatures. If the elastomer is subjected to temperatures lower than the recommended values it will become hard and brittle, however it will regain its properties as soon as the temperature rises again.

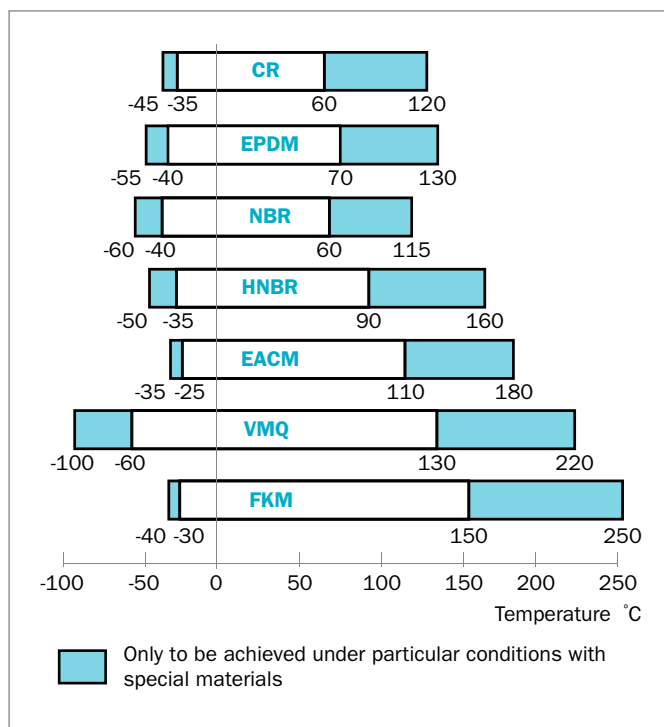

Figure 72: Temperature recommendations for V-Rings

OIL AND SOLVENT RESISTANCE

Since the V-Ring is used primarily for sealing grease lubricated bearings exposed to water splash, dirt, dust, scale etc. the normal choice of compound is Nitrile Rubber N6T50.

However innumerable types of oil are available on the market and each of these has different effect on rubber. In addition, a given type of oil from different manufacturers may have different influence.

It is the additives in the oil that may affect the rubber. Especially so for hypoid oils, that contain sulfur. Since sulfur is used as the vulcanizing agent for Nitrile rubber it will initiate a secondary curing at temperatures above +80 °C. As a result of that, Nitrile rubber will become hard and brittle. Hydrogenated Nitrile and Fluorinated rubbers, which are not vulcanized with sulfur, may therefore be considered for use with this type of oil. Oxidized oils represent another example illustrating the difficulty of tabulating the oil resistance of rubber materials. These oils are oxidized during operation and their properties will therefore change substantially. Such oils break down silicone rubber. Solvents could generally cause deterioration or swelling of the rubber however mixtures of different solvents may cause considerably more damage than a single solvent. An example of this is mixing methanol and hydrocarbons.

For further information on oil and solvent resistance we recommend you to be in contact with your local Trelleborg Sealing Solutions marketing company.

APPLICATION INSTRUCTIONS

The V-Ring is normally fully exposed to the medium to be sealed. The requirements on the shaft and the counterface are mainly dependent on the medium and the peripheral speed.

SHAFT DESIGN

The V-Ring is in most cases fitted on a rotating shaft. The requirements regarding diameter tolerances and surface roughness of the shaft are fairly moderate. As the V-Ring is an all-rubber seal it can be stretched to a varying degree and be used for a wide range of shaft diameters.

In applications where low power loss and long lifetime are important, it is recommended that the V-Ring size is selected, so that the shaft diameter falls between the minimum and nominal values within the recommended range. This is because the contact pressure of the sealing lip increases with the shaft diameter, due to the stretch of the V-Ring. At a higher stretch, a harder contact pressure is generated, causing an accelerated wear of the sealing lip. In order to prevent the V-Ring from sliding along the shaft, and to ensure the correct installation width, it is always recommended to arrange an axial support, especially for small cross-section profiles and larger shaft sizes, for example V-Ring type A, L and LX.



The surface roughness of the shaft should in general not exceed Ra 6.3 µm. For sealing fluids and fine particles, a maximum of Ra 3.2 µm is recommended. Sharp edges and burrs, which can damage the V-Ring must be avoided.

COUNTER-FACE DESIGN

The condition of the counter-face has a great influence on the sealing function. The medium to be sealed and the peripheral speed of the shaft determine the requirements regarding surface roughness and material of the counter-face. It is important that it is smooth and flat without any sharp edges. To achieve the full effect of the flinger action, the V-Ring should always be designed in a relatively open space. Equally important is to keep the gap between the shaft and the counter-face as small as possible, in order to prevent entry of the V-Ring lip during the installation. Recommended application dimensions are given in the dimension tables.

MATERIAL AND MATERIAL HARDNESS

Cold rolled steel sheet, stainless steel or zinc plated sheet are excellent materials for the counter-face. However, the choice of material is highly dependent on the medium to be sealed.

For normal running conditions, conventional mild steel with a hardness of min. 125 HB is sufficient. For sealing against grease, oil and dry particles no further surface treatment is required. With an increase in speed and the presence of abrasive particles the hardness of the counter-face must also be increased.

The following materials are normally used :

Material	Hardness HB	Medium
Mild Steel	125 - 150	Water splash, sand, dust
Grey Cast Iron	190 - 270	Water splash, sand, dust
Sinter Bronze	100 - 160	Water, dust
Stainless Steel (Cr/Ni 18-8, C 0.1%)	150 - 200	Water
Stainless Steel (Cr/Ni 18-8, C 0.15%)	350	Water and abrasive particles
Work-hardened Acid Proof Steel	180 - 200	Chemicals
Tungsten Carbide	350 - 500	Water and scale
Forged Steel	200 - 255	Water and scale
Die-cast Aluminum	90 - 160	Water splash

SURFACE TREATMENT

When the counter-face is exposed to water or other corrosive media, it must be protected accordingly.

Mild steel surfaces should either be zinc-plated and chromated, chromium plated, treated with an anticorrosion spray, or painted. The choice of treatment will depend on the overall running conditions.

Where the seal is immersed in water, stainless steel is recommended. However, due to the poor thermal conductivity of stainless steel it should not be used in dry running conditions unless the speed is slow (< 1 m/s).

SURFACE FINISH

The rate of abrasion of the V-Ring is influenced by a number of factors, one of which is the surface finish of the counter-face. The choice of surface finish will depend on the media to be sealed and the shaft speed as well. It is not only the surface finish value as such that is important, but also the surface character. For turned surfaces, it is recommended to buff the surface with fine emery cloth to remove any sharp peaks arising from the turning operation.

Surfaces with a finish that is too fine, e.g. certain cold rolled steel surfaces, may cause a suction effect between the V-Ring lip and the counter-face resulting in noise problems and uneven running (so-called stick-slip effect).

The counterface surface must be free from scratch marks and other surface damages within the sealing area. This is important when sealing fluids and fine particles are present.

GUIDE TO RECOMMENDED SURFACE FINISH

Surface Finish µm Ra	Speed m/s	Medium
0.4 - 0.8	> 10	Oil, water, scale, fiber
0.8 - 1.6	5 - 10	Oil splash, grease, water splash
1.6 - 2.0	1 - 5	Grease, dust, water splash, scale
2.0 - 2.5	< 1	Grease, dust

The surface finish should not be lower than Ra 0.05 µm.

FLATNESS

The flatness of the counter-face is of importance, especially at higher shaft speeds.

The maximum permissible flatness deviation is normally defined as 0.4 mm per 100 mm.



■ Installation

AXIAL SUPPORT

When used to retain oil and grease, an axial support for the V-Ring is always required. For applications with a lower degree of stretch than recommended in the dimension tables (e.g. for ease of assembly) or with a shaft speed exceeding 6 - 8 m/s (depending on the rubber compound selected) an axial support is also necessary.

An axial support can ensure that the correct installation width relative to the counter-face is maintained for blind assemblies.

The V-Ring must always be supported over its entire base. The axial support should be designed in accordance with Figure 73. The dimensions A, c, d_1 , d_3 and B_1 are shown in the dimension tables.

Calculation of the axial support diameter d_5 is as follows;

Table 49: Axial Diameter d_5

V-Ring Type	min. Diameter d_5
A, S	$d_1 + 0.5 \times c$
L, LX	$d_1 + 3 \text{ mm}$
RM, RME	$d_1 + 10 \text{ mm}$
AX	$d_1 + 9 \text{ mm}$

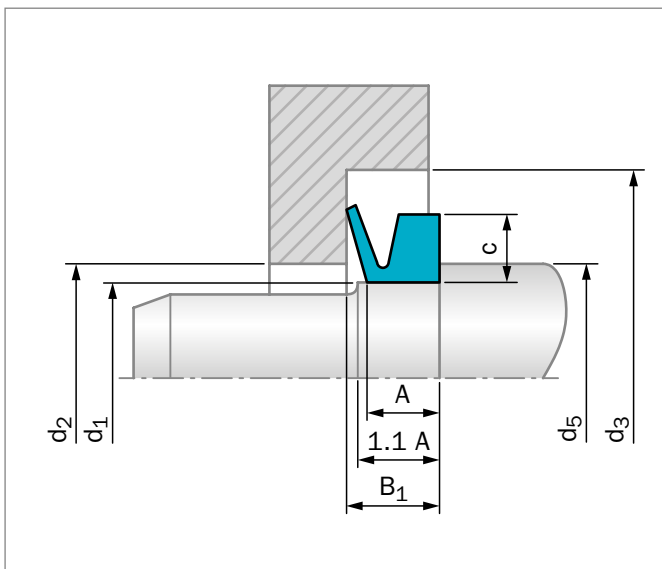

Figure 73: Axial support

RADIAL RETENTION

When the V-Ring is fitted on the shaft, the body of the V-Ring is subject to centrifugal force and tends to move or even lift off from the shaft at a certain speed.

At shaft speeds over 10 - 12 m/s, depending on the V-Ring material, the V-Ring in general requires radial retention. The speed when radial retention is required is also dependent on the degree of stretch of the V-Ring. V-Rings larger than 2000 mm should always be fitted with radial retention, irrespective of the operating speed.

The radial retention can be designed as a recess, in which the V-Ring body fits, or consist of a number of separate clamping segments. Please contact your local Trelleborg Sealing Solutions marketing company for further guidance.

The clamping band type A or RM are other useful alternatives (see page 156.)

STATIONARY ASSEMBLY

In cases where the peripheral speed of the shaft exceeds 10 - 12 m/s an alternative method to radial clamping is to mount the V-Ring on a stationary component in the unit. The contact pressure of the lip will remain constant, as there will be no centrifugal force acting upon the lip.

In comparison to a rotating V-Ring, friction and power loss will be higher resulting in somewhat shorter service life. In order to compensate for this the following steps should be taken:

Counter-face surface finish:

- machine to max. 0.8 $\mu\text{m Ra}$

V-Ring stretch:

- maximum 4 - 6%

Axial interference:

- keep to the minimum requirements for compensation of the axial movement within the assembly.

At higher peripheral speed adequate lubrication and heat transfer from the counter-face are required.

TORQUE

The torque, and consequently the power loss due to the friction of the seal, is often of such a magnitude that it should be taken into consideration when deciding seal type. This applies particularly in the case of small electrical motors, conveyor rollers or any unit where low friction is an important requirement. The power losses are influenced by many factors such as the seal design and compound, surface finish of the counter-face, fitted width and stretch, speed, medium, lubricant, temperature etc.



For this reason it is difficult to give exact torque values for all running conditions.

Generally speaking, the power losses resulting from a V-Ring are always lower than a corresponding radial oil seal. Grease lubrication gives higher power losses than oil lubrication or dry running.

By applying a suitable low friction dry film lubricant on the counter-face surface the friction and the heat generated can be reduced.

An increase of the fitted width of the V-Ring, giving a reduced lip pressure, will also lower the friction. However, the total axial movement in the assembly must be considered in order not to exceed the tolerances shown in the dimension tables. Whenever detailed information about power losses is required, consult your local Trelleborg Sealing Solutions marketing company.

INSTALLATION GUIDELINES

When the V-Ring is used as a grease seal/contaminant excluder, the V-Ring is normally mounted on the outside of a bearing housing, with or without, axial support.

General rules:

1. The V-Ring, the counter-face and the shaft should be clean
2. The shaft should preferably be dry and free from grease or oil, particularly when the V-Ring is mounted without axial support
3. The lip of the V-Ring should be lubricated with a thin film of grease or silicone oil
4. In cases when friction must be reduced to a minimum, coat the counter-face with a low friction agent, and do not apply grease to the lip
5. Ensure that the V-Ring is mounted with a uniform stretch around the shaft

When the V-Ring is mounted on the shaft the outer diameter of the lip is reduced. Unless the stretch is uniform this reduction will vary around the periphery. This may lead to partial entry of the lip in the bore of the counter-face when the seal is pushed into position.

In the case of large diameter seals a uniform stretch can be achieved by inserting a blunt screwdriver or a piece of string under the V-Ring body and running it around the shaft twice. Take care not to damage seal or shaft.

The most convenient method of assembling large diameter V-Ring's, to ensure uniform stretch, is to mark off the body of the V-Ring and the shaft or seating with six equidistant marks. The marks should then be matched together when the V-Ring is fitted in position.

For more detailed installation instructions, contact your local Trelleborg Sealing Solutions marketing company.

CLAMPING BAND

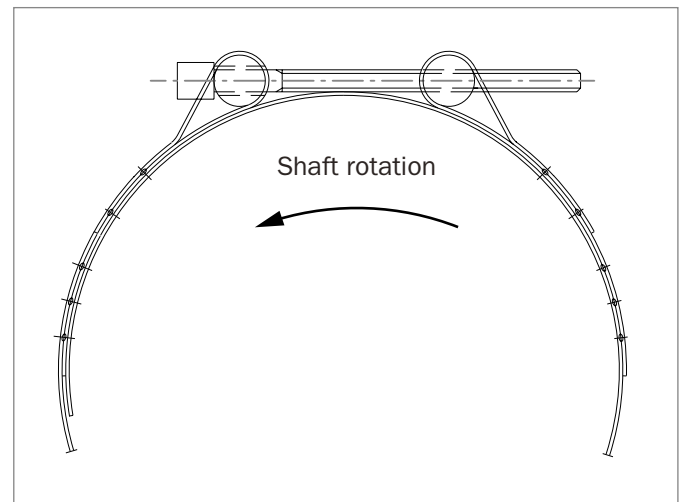

Figure 74: Clamping band RM

CLAMPING BAND RM

For clamping large diameter V-Rings of the RM and RME types, the Clamping Band RM is recommended.

Together with Clamping Band RM a special series of "low stretch" V-Rings can be used for shaft diameters larger than 1,500 mm. This will reduce torque and facilitate the fitting of the V-Ring.

When ordering the Clamping Band RM, simply state the shaft diameter for which the clamping band is intended. Each clamping band is comprised of a set of standard lengths measuring 1,000 mm and 1,500 mm depending on the size, standard attachments and, if necessary, an adjustable length and two set of rivets. When the parts are assembled, the clamping band will fit the specific V-Ring.

All parts are made of acid-proof steel with the exception of the pop rivets, which are made of conventional stainless steel. If operation conditions dictate the use of acid-proof steel, the conventional rivets must be used in conjunction with the adjustable length.



FITTING THE CLAMPING BAND RM

Trim the adjustable clamping band to the right length by using a pair of shears. Rivet the adjustable length and the end attachment together by using a standard pop riveter and the three pop rivets.

Locate the V-Ring in correct position relative to the counterface, i.e. the predetermined B_1 dimension.

Smear the V-Ring with a thin film of grease in the groove designed for the clamping band.

Using the attachments supplied with the band sections, join them together and position the complete band in the body groove with the screw heads facing the direction of shaft rotation. Turn the attachment screws a few turns one by one until the band is tight.

Check that the entire band fits snugly in the body groove.

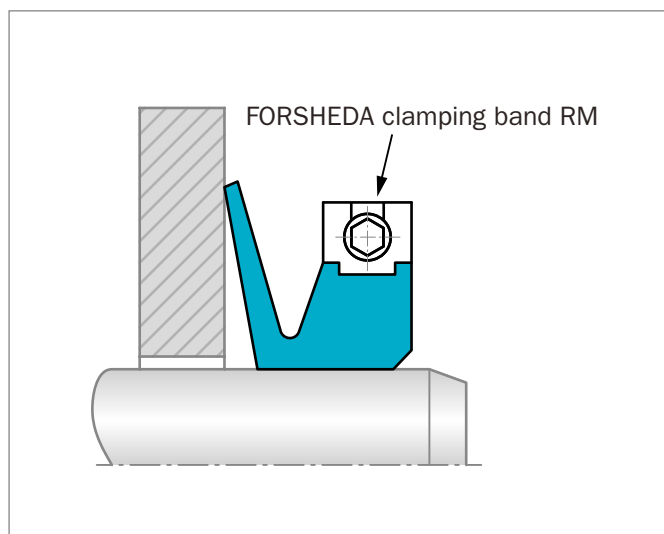

Figure 75: Clamping Band RM

CLAMPING BAND A/AX

The clamping band A/AX is meant to be used with V-Rings type A and AX on shaft diameters from 200mm and larger. The clamping band keeps the V-ring in position both axially and radially and can be re-used several times. The clamping band is supplied in 5m lengths. Screw joints to connect the clamping band as well as the buckle are ordered on separate article number. The band is made of stainless steel AISI 301, the screw joint is made of AISI 304 with galvanized screw. To order the right size and for the correct installation, please contact your local Trelleborg Sealing Solutions Marketing Company.

TSS part numbers for clamping band A

Clamping Band 5000 mm	XZYDFAE002
Clamping Band RM	on request
Screw joint	XZYDF00022
Buckles	XZYDFAR001

IN-SITU JOINING

To avoid unnecessary downtime and difficult dismantling when carrying out preventive maintenance of process machinery, it is possible to split the V-Ring, fold it around the shaft and join it.

The V-Ring can be supplied either as a complete ring and cut on site, or supplied in the split condition from the factory. For V-Rings types RM and RME it is preferable to split the seals at the factory due to the size of the section.

The best method of joining a V-Ring is by vulcanizing. Portable vulcanizing tools for the different V-Rings profiles, vulcanizing cement and detailed instructions are available from your local Trelleborg Sealing Solutions marketing company.



V-Ring Type A

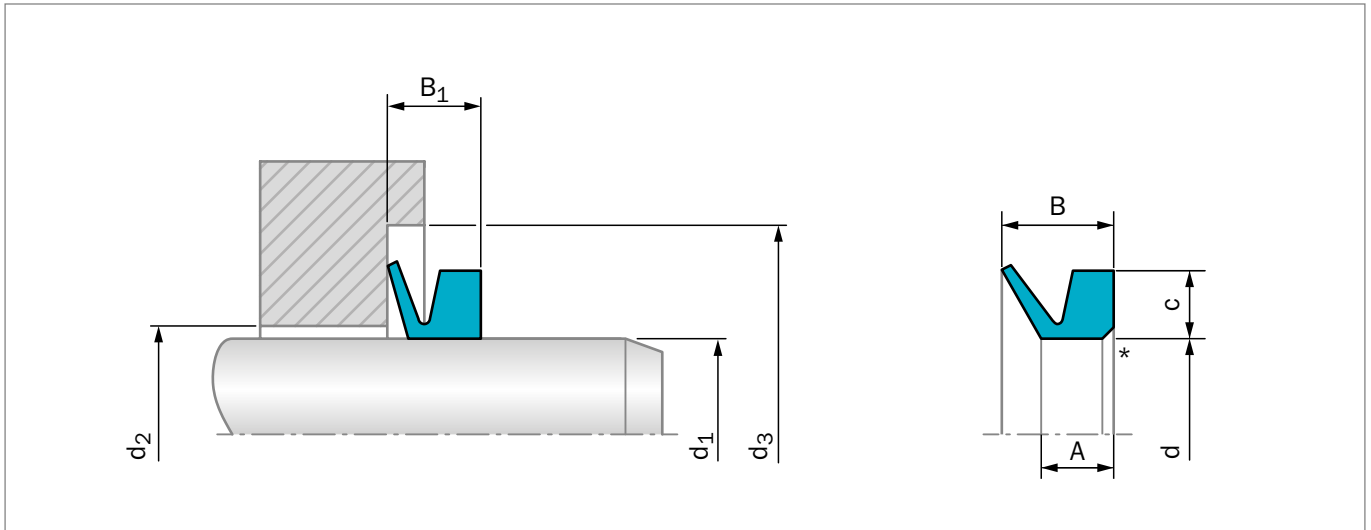

Figure 76: Installation Drawing

* V-ring type A partly with chamfer

When the shaft diameter d_1 is on the boundary between two sizes of V-Ring, select the larger V-Ring.
All dimensions in mm.

ORDERING EXAMPLE END V-RING TYPE A

Type: A, for shaft diameter = 30.0 mm
Material: N6T50 (Nitrile Elastomer)

TSS Article No. TWVA00300 - N6T50
TSS Part No. _____
Quality Index (Standard) _____
Material No. (Standard) _____

Table 50: Profile Dimensions – Assembly Dimensions

For Shaft Diameter	Inside Dia.	Height of Cross-Section-Ø	Dimension	Free Width	Maximum	Minimum	Fitted Width	V-Ring FORSHEDA Ref.	TSS Part No.
d_1	d	c	A	B	d_2	d_3	B_1		
2.7 - 3.5	2.5	1.5	2.1	3.0	$d_1 + 1$	$d_1 + 4$	2.5 ± 0.3	V-3A	TWVA00030
3.5 - 4.5	3.2	2	2.4	3.7	$d_1 + 1$	$d_1 + 6$	3.0 ± 0.4	V-4A	TWVA00040
4.5 - 5.5	4	2	2.4	3.7	$d_1 + 1$	$d_1 + 6$	3.0 ± 0.4	V-5A	TWVA00050
5.5 - 6.5	5	2	2.4	3.7	$d_1 + 1$	$d_1 + 6$	3.0 ± 0.4	V-6A	TWVA00060
6.5 - 8.0	6	2	2.4	3.7	$d_1 + 1$	$d_1 + 6$	3.0 ± 0.4	V-7A	TWVA00070
8.0 - 9.5	7	2	2.4	3.7	$d_1 + 1$	$d_1 + 6$	3.0 ± 0.4	V-8A	TWVA00080
9.5 - 11.5	9	3	3.4	5.5	$d_1 + 1$	$d_1 + 9$	4.5 ± 0.6	V-10A	TWVA00100
11.5 - 12.5	10.5	3	3.4	5.5	$d_1 + 1$	$d_1 + 9$	4.5 ± 0.6	V-12A	TWVA00120
12.5 - 13.5	11.7	3	3.4	5.5	$d_1 + 1$	$d_1 + 9$	4.5 ± 0.6	V-13A	TWVA00130
13.5 - 15.5	12.5	3	3.4	5.5	$d_1 + 1$	$d_1 + 9$	4.5 ± 0.6	V-14A	TWVA00140
15.5 - 17	14	3	3.4	5.5	$d_1 + 1$	$d_1 + 9$	4.5 ± 0.6	V-16A	TWVA00160
17.5 - 19	16	3	3.4	5.5	$d_1 + 1$	$d_1 + 9$	4.5 ± 0.6	V-18A	TWVA00180



For Shaft Diameter	Inside Dia.	Height of Cross-Section-Ø	Dimension	Free Width	Maximum	Minimum	Fitted Width	V-Ring FORSHEDA Ref.	TSS Part No.
d_1	d	c	A	B	d_2	d_3	B_1		
19 - 21	18	4	4.7	7.5	$d_1 + 2$	$d_1 + 12$	6.0 ± 0.8	V-20A	TWVA00200
21 - 24	20	4	4.7	7.5	$d_1 + 2$	$d_1 + 12$	6.0 ± 0.8	V-22A	TWVA00220
24 - 27	22	4	4.7	7.5	$d_1 + 2$	$d_1 + 12$	6.0 ± 0.8	V-25A	TWVA00250
27 - 29	25	4	4.7	7.5	$d_1 + 2$	$d_1 + 12$	6.0 ± 0.8	V-28A	TWVA00280
29 - 31	27	4	4.7	7.5	$d_1 + 2$	$d_1 + 12$	6.0 ± 0.8	V-30A	TWVA00300
31 - 33	29	4	4.7	7.5	$d_1 + 2$	$d_1 + 12$	6.0 ± 0.8	V-32A	TWVA00320
33 - 36	31	4	4.7	7.5	$d_1 + 2$	$d_1 + 12$	6.0 ± 0.8	V-35A	TWVA00350
36 - 38	34	4	4.7	7.5	$d_1 + 2$	$d_1 + 12$	6.0 ± 0.8	V-38A	TWVA00380
38 - 43	36	5	5.5	9.0	$d_1 + 2$	$d_1 + 15$	7.0 ± 1.0	V-40A	TWVA00400
43 - 48	40	5	5.5	9.0	$d_1 + 2$	$d_1 + 15$	7.0 ± 1.0	V-45A	TWVA00450
48 - 53	45	5	5.5	9.0	$d_1 + 2$	$d_1 + 15$	7.0 ± 1.0	V-50A	TWVA00500
53 - 58	49	5	5.5	9.0	$d_1 + 2$	$d_1 + 15$	7.0 ± 1.0	V-55A	TWVA00550
58 - 63	54	5	5.5	9.0	$d_1 + 2$	$d_1 + 15$	7.0 ± 1.0	V-60A	TWVA00600
63 - 68	58	5	5.5	9.0	$d_1 + 2$	$d_1 + 15$	7.0 ± 1.0	V-65A	TWVA00650
68 - 73	63	6	6.8	11.0	$d_1 + 3$	$d_1 + 18$	9.0 ± 1.2	V-70A	TWVA00700
73 - 78	67	6	6.8	11.0	$d_1 + 3$	$d_1 + 18$	9.0 ± 1.2	V-75A	TWVA00750
78 - 83	72	6	6.8	11.0	$d_1 + 3$	$d_1 + 18$	9.0 ± 1.2	V-80A	TWVA00800
83 - 88	76	6	6.8	11.0	$d_1 + 3$	$d_1 + 18$	9.0 ± 1.2	V-85A	TWVA00850
88 - 93	81	6	6.8	11.0	$d_1 + 3$	$d_1 + 18$	9.0 ± 1.2	V-90A	TWVA00900
93 - 98	85	6	6.8	11.0	$d_1 + 3$	$d_1 + 18$	9.0 ± 1.2	V-95A	TWVA00950
98 - 105	90	6	6.8	11.0	$d_1 + 3$	$d_1 + 18$	9.0 ± 1.2	V-100A	TWVA01000
105 - 115	99	7	7.9	12.8	$d_1 + 4$	$d_1 + 21$	10.5 ± 1.5	V-110A	TWVA01100
115 - 125	108	7	7.9	12.8	$d_1 + 4$	$d_1 + 21$	10.5 ± 1.5	V-120A	TWVA01200
125 - 135	117	7	7.9	12.8	$d_1 + 4$	$d_1 + 21$	10.5 ± 1.5	V-130A	TWVA01300
135 - 145	126	7	7.9	12.8	$d_1 + 4$	$d_1 + 21$	10.5 ± 1.5	V-140A	TWVA01400
145 - 155	135	7	7.9	12.8	$d_1 + 4$	$d_1 + 21$	10.5 ± 1.5	V-150A	TWVA01500
155 - 165	144	8	9.0	14.5	$d_1 + 4$	$d_1 + 24$	12.0 ± 1.8	V-160A	TWVA01600
165 - 175	153	8	9.0	14.5	$d_1 + 4$	$d_1 + 24$	12.0 ± 1.8	V-170A	TW8VA01700
175 - 185	162	8	9.0	14.5	$d_1 + 4$	$d_1 + 24$	12.0 ± 1.8	V-180A	TWVA01800
185 - 195	171	8	9.0	14.5	$d_1 + 4$	$d_1 + 24$	12.0 ± 1.8	V-190A	TWVA01900
195 - 210	180	8	9.0	14.5	$d_1 + 4$	$d_1 + 24$	12.0 ± 1.8	V-199A	TWVA01990
190 - 210	180	15	14.3	25.0	$d_1 + 10$	$d_1 + 45$	20.0 ± 4.0	V-200A	TWVA02000
210 - 235	198	15	14.3	25.0	$d_1 + 10$	$d_1 + 45$	20.0 ± 4.0	V-220A	TWVA02200
235 - 265	225	15	14.3	25.0	$d_1 + 10$	$d_1 + 45$	20.0 ± 4.0	V-250A	TWVA02500
265 - 290	247	15	14.3	25.0	$d_1 + 10$	$d_1 + 45$	20.0 ± 4.0	V-275A	TWVA02750
290 - 310	270	15	14.3	25.0	$d_1 + 10$	$d_1 + 45$	20.0 ± 4.0	V-300A	TWVA03000
310 - 335	292	15	14.3	25.0	$d_1 + 10$	$d_1 + 45$	20.0 ± 4.0	V-325A	TWVA03250
335 - 365	315	15	14.3	25.0	$d_1 + 10$	$d_1 + 45$	20.0 ± 4.0	V-350A	TWVA03500
365 - 390	337	15	14.3	25.0	$d_1 + 10$	$d_1 + 45$	20.0 ± 4.0	V-375A	TWVA03750
390 - 430	360	15	14.3	25.0	$d_1 + 10$	$d_1 + 45$	20.0 ± 4.0	V-400A	TWVA04000
430 - 480	405	15	14.3	25.0	$d_1 + 10$	$d_1 + 45$	20.0 ± 4.0	V-450A	TWVA04500



For Shaft Diameter	Inside Dia.	Height of Cross-Section-Ø	Dimension	Free Width	Maximum	Minimum	Fitted Width	V-Ring FORSHEDA Ref.	TSS Part No.
d ₁	d	c	A	B	d ₂	d ₃	B ₁		
480 - 530	450	15	14.3	25.0	d1 + 10	d1 + 45	20.0 ±4.0	V-500A	TWVA05000
530 - 580	495	15	14.3	25.0	d1 + 10	d1 + 45	20.0 ±4.0	V-550A	TWVA05500
580 - 630	540	15	14.3	25.0	d1 + 10	d1 + 45	20.0 ±4.0	V-600A	TWVA06000
630 - 665	600	15	14.3	25.0	d1 + 10	d1 + 45	20.0 ±4.0	V-650A	TWVA06500
665 - 705	630	15	14.3	25.0	d1 + 10	d1 + 45	20.0 ±4.0	V-700A	TWVA07000
705 - 745	670	15	14.3	25.0	d1 + 10	d1 + 45	20.0 ±4.0	V-725A	TWVA07250
745 - 785	705	15	14.3	25.0	d1 + 10	d1 + 45	20.0 ±4.0	V-750A	TWVA07500
785 - 830	745	15	14.3	25.0	d1 + 10	d1 + 45	20.0 ±4.0	V-800A	TWVA08000
830 - 875	785	15	14.3	25.0	d1 + 10	d1 + 45	20.0 ±4.0	V-850A	TWVA08500
875 - 920	825	15	14.3	25.0	d1 + 10	d1 + 45	20.0 ±4.0	V-900A	TWVA09000
920 - 965	865	15	14.3	25.0	d1 + 10	d1 + 45	20.0 ±4.0	V-950A	TWVA09500
965 - 1015	910	15	14.3	25.0	d1 + 10	d1 + 45	20.0 ±4.0	V-1000A	TWVAX1000
1,015 - 1,065	955	15	14.3	25.0	d1 + 10	d1 + 45	20.0 ±4.0	V-1050A	TWVAX1050
1,065 - 1,115	1,000	15	14.3	25.0	d1 + 10	d1 + 45	20.0 ±4.0	V-1100A	TWVAW1100
1,115 - 1,165	1,045	15	14.3	25.0	d1 + 10	d1 + 45	20.0 ±4.0	V-1150A	TWVAW1150
1,165 - 1,215	1,090	15	14.3	25.0	d1 + 10	d1 + 45	20.0 ±4.0	V-1200A	TWVAW1200
1,215 - 1,270	1,135	15	14.3	25.0	d1 + 10	d1 + 45	20.0 ±4.0	V-1250A	TWVAW1250
1,270 - 1,320	1,180	15	14.3	25.0	d1 + 10	d1 + 45	20.0 ±4.0	V-1300A	TWVAW1300
1,320 - 1,370	1,225	15	14.3	25.0	d1 + 10	d1 + 45	20.0 ±4.0	V-1350A	TWVAW1350
1,370 - 1,420	1,270	15	14.3	25.0	d1 + 10	d1 + 45	20.0 ±4.0	V-1400A	TWVAW1400
1,420 - 1,470	1,315	15	14.3	25.0	d1 + 10	d1 + 45	20.0 ±4.0	V-1450A	TWVAW1450
1,470 - 1,520	1,360	15	14.3	25.0	d1 + 10	d1 + 45	20.0 ±4.0	V-1500A	TWVAW1500
1,520 - 1,570	1,405	15	14.3	25.0	d1 + 10	d1 + 45	20.0 ±4.0	V-1550A	TWVAW1550
1,570 - 1,620	1,450	15	14.3	25.0	d1 + 10	d1 + 45	20.0 ±4.0	V-1600A	TWVAW1600
1,620 - 1,670	1,495	15	14.3	25.0	d1 + 10	d1 + 45	20.0 ±4.0	V-1650A	TWVAW1650
1,670 - 1,720	1,540	15	14.3	25.0	d1 + 10	d1 + 45	20.0 ±4.0	V-1700A	TWVAW1700
1,720 - 1,770	1,585	15	14.3	25.0	d1 + 10	d1 + 45	20.0 ±4.0	V-1750A	TWVAW1750
1,770 - 1,820	1,630	15	14.3	25.0	d1 + 10	d1 + 45	20.0 ±4.0	V-1800A	TWVAW1800
1,820 - 1,870	1,675	15	14.3	25.0	d1 + 10	d1 + 45	20.0 ±4.0	V-1850A	TWVAW1850
1,870 - 1,920	1,720	15	14.3	25.0	d1 + 10	d1 + 45	20.0 ±4.0	V-1900A	TWVA W1900
1,920 - 1,970	1,765	15	14.3	25.0	d1 + 10	d1 + 45	20.0 ±4.0	V-1950A	TWVAW1950
1,970 - 2,020	1,810	15	14.3	25.0	d1 + 10	d1 + 45	20.0 ±4.0	V-2000A	TWVAW2000

V-Ring A for a shaft size larger than 2,020 mm can be made to order.



V-Ring Type S

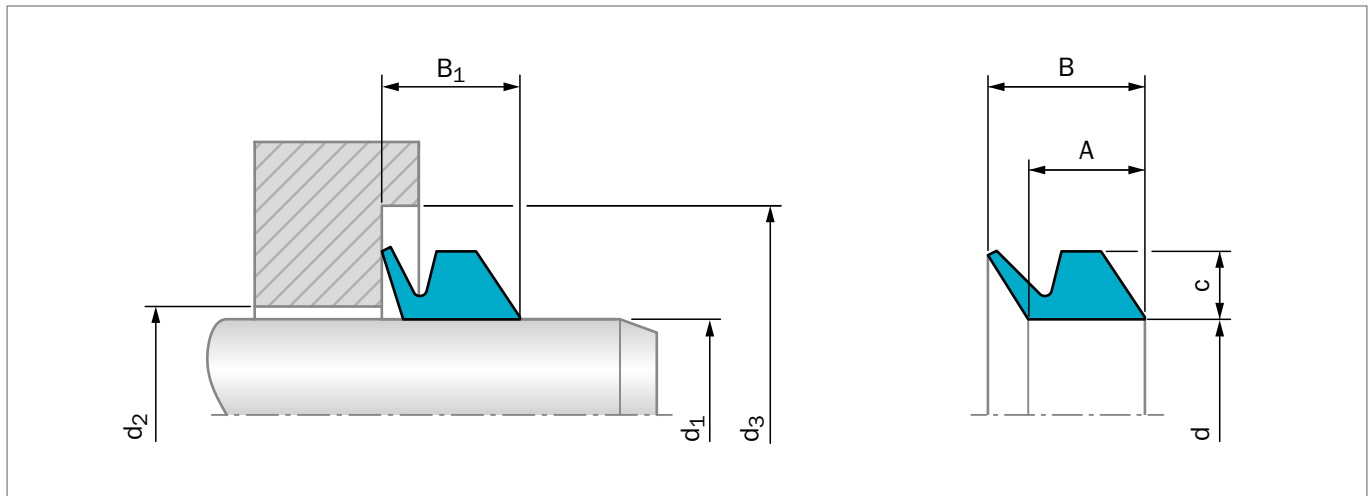

Figure 77: Installation Drawing

When the dimension d_1 is on the boundary between two sizes of V-Ring, select the larger V-Ring. All dimensions in mm.

ORDERING EXAMPLE END V-RING

Type:	S, for shaft diameter = 30.0 mm
Material:	N6T50 (Nitrile Elastomer)

TSS Article No. TWVS00300 - N6T50

TSS Part No. _____
 Quality Index (Standard) _____
 Material No. (Standard) _____

Table 51: Profile Dimensions – Assembly Dimensions

For Shaft Diameter	Inside Dia.	Height of Cross-Section-Ø	Dimension	Free Width	Maximum	Minimum	Fitted Width	V-Ring FORSHEDA Ref.	TSS Part No.
d_1	d	c	A	B	d_2	d_3	B_1		
4.5 - 5.5	4	2	3.9	5.2	$d_1 + 1$	$d_1 + 6$	4.5 ± 0.4	V-5S	TWVS00050
5.5 - 6.5	5	2	3.9	5.2	$d_1 + 1$	$d_1 + 6$	4.5 ± 0.4	V-6S	TWVS00060
6.5 - 8.0	6	2	3.9	5.2	$d_1 + 1$	$d_1 + 6$	4.5 ± 0.4	V-7S	TWVS00070
8.0 - 9.5	7	2	3.9	5.2	$d_1 + 1$	$d_1 + 6$	4.5 ± 0.4	V-8S	TWVS00080
9.5 - 11.5	9	3	5.6	7.7	$d_1 + 1$	$d_1 + 9$	6.7 ± 0.6	V-10S	TWVS00100
11.5 - 13.5	10.5	3	5.6	7.7	$d_1 + 1$	$d_1 + 9$	6.7 ± 0.6	V-12S	TWVS00120
13.5 - 15.5	12.5	3	5.6	7.7	$d_1 + 1$	$d_1 + 9$	6.7 ± 0.6	V-14S	TWVS00140
15.5 - 17.5	14	3	5.6	7.7	$d_1 + 1$	$d_1 + 9$	6.7 ± 0.6	V-16S	TWVS00160
17.5 - 19	16	3	5.6	7.7	$d_1 + 1$	$d_1 + 9$	6.7 ± 0.6	V-18S	TWVS00180
19 - 21	18	4	7.9	10.5	$d_1 + 2$	$d_1 + 12$	9.0 ± 0.8	V-20S	TWVS00200



For Shaft Diameter	Inside Dia.	Height of Cross-Section-Ø	Dimension	Free Width	Maximum	Minimum	Fitted Width	V-Ring FORSHEDA Ref.	TSS Part No.
d_1	d	c	A	B	d_2	d_3	B_1		
21 - 24	20	4	7.9	10.5	$d_1 + 2$	$d_1 + 12$	9.0 ± 0.8	V-22S	TWVS00220
24 - 27	22	4	7.9	10.5	$d_1 + 2$	$d_1 + 12$	9.0 ± 0.8	V-25S	TWVS00250
27 - 29	25	4	7.9	10.5	$d_1 + 2$	$d_1 + 12$	9.0 ± 0.8	V-28S	TWVS00280
29 - 31	27	4	7.9	10.5	$d_1 + 2$	$d_1 + 12$	9.0 ± 0.8	V-30S	TWVS00300
31 - 33	29	4	7.9	10.5	$d_1 + 2$	$d_1 + 12$	9.0 ± 0.8	V-32S	TWVS00320
33 - 36	31	4	7.9	10.5	$d_1 + 2$	$d_1 + 12$	9.0 ± 0.8	V-35S	TWVS00350
36 - 38	34	4	7.9	10.5	$d_1 + 2$	$d_1 + 12$	9.0 ± 0.8	V-38S	TWVS00380
38 - 43	36	5	9.5	13.0	$d_1 + 2$	$d_1 + 15$	11.0 ± 1.0	V-40S	TWVS00400
43 - 48	40	5	9.5	13.0	$d_1 + 2$	$d_1 + 15$	11.0 ± 1.0	V-45S	TWVS00450
48 - 53	45	5	9.5	13.0	$d_1 + 2$	$d_1 + 15$	11.0 ± 1.0	V-50S	TWVS00500
53 - 58	49	5	9.5	13.0	$d_1 + 2$	$d_1 + 15$	11.0 ± 1.0	V-55S	TWVS00550
58 - 63	54	5	9.5	13.0	$d_1 + 2$	$d_1 + 15$	11.0 ± 1.0	V-60S	TWVS00600
63 - 68	58	5	9.5	13.0	$d_1 + 2$	$d_1 + 15$	11.0 ± 1.0	V-65S	TWVS00650
68 - 73	63	6	11.3	15.5	$d_1 + 3$	$d_1 + 18$	13.5 ± 1.2	V-70S	TWVS00700
73 - 78	67	6	11.3	15.5	$d_1 + 3$	$d_1 + 18$	13.5 ± 1.2	V-75S	TWVS00750
78 - 83	72	6	11.3	15.5	$d_1 + 3$	$d_1 + 18$	13.5 ± 1.2	V-80S	TWVS00800
83 - 88	76	6	11.3	15.5	$d_1 + 3$	$d_1 + 18$	13.5 ± 1.2	V-85S	TWVS00850
88 - 93	81	6	11.3	15.5	$d_1 + 3$	$d_1 + 18$	13.5 ± 1.2	V-90S	TWVS00900
93 - 98	85	6	11.3	15.5	$d_1 + 3$	$d_1 + 18$	13.5 ± 1.2	V-95S	TWVS00950
98 - 105	90	6	11.3	15.5	$d_1 + 3$	$d_1 + 18$	13.5 ± 1.2	V-100S	TWVS01000
105 - 115	99	7	13.1	18.0	$d_1 + 4$	$d_1 + 21$	15.5 ± 1.5	V-110S	TWVS01100
115 - 125	108	7	13.1	18.0	$d_1 + 4$	$d_1 + 21$	15.5 ± 1.5	V-120S	TWVS01200
125 - 135	117	7	13.1	18.0	$d_1 + 4$	$d_1 + 21$	15.5 ± 1.5	V-130S	TWVS01300
135 - 145	126	7	13.1	18.0	$d_1 + 4$	$d_1 + 21$	15.5 ± 1.5	V-140S	TWVS01400
145 - 155	135	7	13.1	18.0	$d_1 + 4$	$d_1 + 21$	15.5 ± 1.5	V-150S	TWVS01500
155 - 165	144	8	15.0	20.5	$d_1 + 4$	$d_1 + 24$	18.0 ± 1.8	V-160S	TWVS01600
165 - 175	153	8	15.0	20.5	$d_1 + 4$	$d_1 + 24$	18.0 ± 1.8	V-170S	TWVS01700
175 - 185	162	8	15.0	20.5	$d_1 + 4$	$d_1 + 24$	18.0 ± 1.8	V-180S	TWVS01800
185 - 195	171	8	15.0	20.5	$d_1 + 4$	$d_1 + 24$	18.0 ± 1.8	V-190S	TWVS01900
195 - 210	180	8	15.0	20.5	$d_1 + 4$	$d_1 + 24$	18.0 ± 1.8	V-199S	TWVS01990



V-Ring Type L/LX

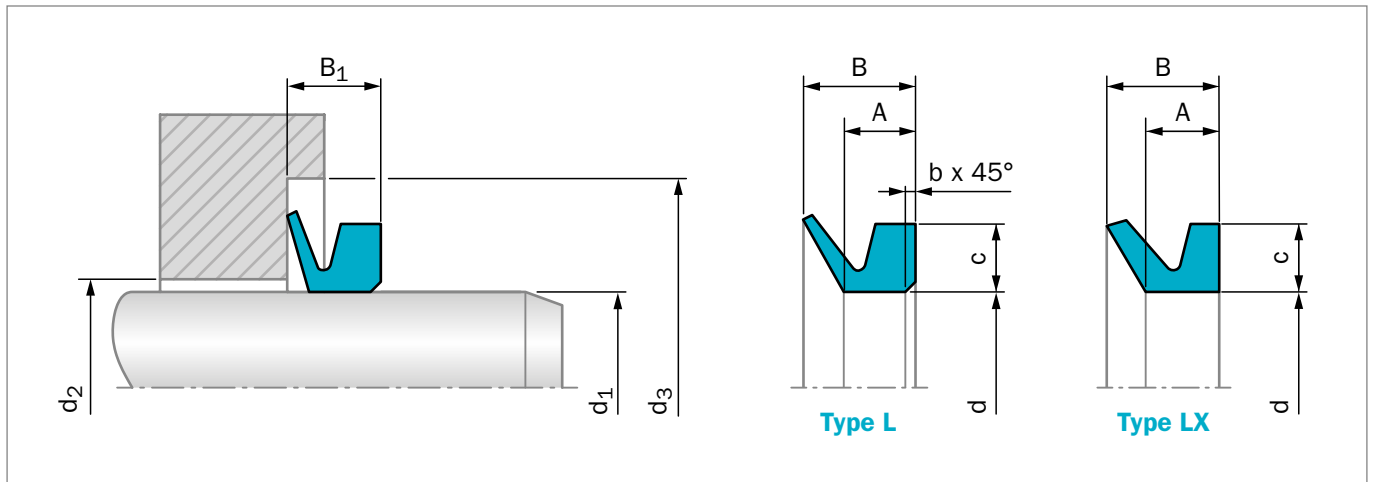

Figure 78: Installation Drawing

When the dimension d_1 is on the boundary between two sizes of V-Ring, select the larger V-Ring. All dimensions in mm.

Table 52: Installation Dimensions

Type	c	A	B	b	B ₁	d ₃ min	d ₂ max
L	6.5	6	10.5	1	8 ± 1.5	d ₁ + 20	d ₁ + 5
LX	5	5.4	8.5	0	6.8 ± 1.1	d ₁ + 15	d ₁ + 4

ORDERING EXAMPLES

Type: L, for shaft diameter = 205 mm
Material: N6T50 (Nitrile Elastomer)

Type: LX, for shaft diameter = 205 mm
Material: N6T50 (Nitrile Elastomer)

TSS Article No. TWVL02000 - N6T50
 TSS Part No. _____
 Quality Index (Standard) _____
 Material No. (Standard) _____

TSS Article No. TWLXV2000 - N6T50
 TSS Part No. _____
 Quality Index (Standard) _____
 Material No. (Standard) _____



Table 53: Profile Dimensions – Assembly Dimensions

For Shaft Diameter d₁	Inside Diameter d	V-Ring FORSHEDA Ref.	TSS Part No.	TSS Part No.
			Type L	Type LX
105 - 115	99	V-110L	TWVL01100	
115 - 125	108	V-120L	TWVL01200	
125 - 135	117	V-130L	TWVL01300	
135 - 145	126	V-140L/LX	TWVL01400	TWLX01400
145 - 155	135	V-150L/LX	TWVL01500	TWLX01500
155 - 165	144	V-160L/LX	TWVL01600	TWLXV1600
165 - 175	153	V-170L/LX	TWVL01700	TWLXV1700
175 - 185	162	V-180L/LX	TWVL01800	TWLXV1800
185 - 195	171	V-190L/LX	TWVL01900	TWLXV1900
195 - 210	182	V-200L/LX	TWVL02000	TWLXV2000
210 - 233	198	V-220L/LX	TWVL02200	TWLXV2200
233 - 260	225	V-250L/LX	TWVL02500	TWLXV2500
260 - 285	247	V-275L/LX	TWVL02750	TWLXV2750
285 - 310	270	V-300L/LX	TWVL03000	TWLXV3000
310 - 335	292	V-325L/LX	TWVL03250	TWLXV3250
335 - 365	315	V-350L/LX	TWVL03500	TWLXV3500
365 - 385	337	V-375L/LX	TWVL03750	TWLXV3750
385 - 410	360	V-400L/LX	TWVL04000	TWLXV4000
410 - 440	382	V-425L/LX	TWVL04250	TWLXV4250
440 - 475	405	V-450L/LX	TWVL04500	TWLXV4500
475 - 510	450	V-500L/LX	TWVLV5000	TWLXV5000
510 - 540	472	V-525L/LX	TWVLV5250	TWLXV5250
540 - 575	495	V-550L/LX	TWVLV5500	TWLXV5500
575 - 625	540	V-600L/LX	TWVLV6000	TWLXV6000
625 - 675	600	V-650L/LX	TWVLV6500	TWLXV6500
675 - 710	630	V-700L/LX	TWVLV7000	TWLXV7000
710 - 740	670	V-725L/LX	TWVLV7250	TWLXV7250
740 - 775	705	V-750L/LX	TWVLV7500	TWLXV7500
775 - 825	745	V-800L/LX	TWVL08000	TWLXV8000
825 - 875	785	V-850L/LX	TWVLV8500	TWLXV8500
875 - 925	825	V-900L/LX	TWVLV9000	TWLXV9000
925 - 975	865	V-950L/LX	TWVLV9500	TWLXV9500
975 - 1,025	910	V-1000L/LX	TWVLW1000	TWLXW1000
1,025 - 1,075	955	V-1050L/LX	TWVLW1050	TWLXW1050
1,075 - 1,125	1,000	V-1100L/LX	TWVLW1100	TWLXW1100
1,125 - 1,175	1,045	V-1150L/LX	TWVLW1150	TWLXW1150
1,175 - 1,225	1,090	V-1200L/LX	TWVLW1200	TWLXW1200
1,225 - 1,275	1,135	V-1250L/LX	TWVLW1250	TWLXW1250
1,275 - 1,325	1,180	V-1300L/LX	TWVLW1300	TWLXW1300
1,325 - 1,375	1,225	V-1350L/LX	TWVLW1350	TWLXW1350
1,375 - 1,425	1,270	V-1400L/LX	TWVLW1400	TWLXW1400
1,425 - 1,475	1,315	V-1450L/LX	TWVLW1450	TWLXW1450



For Shaft Diameter	Inside Diameter	V-Ring	TSS Part No.	TSS Part No.
d_1	d	FORSHEDA Ref.	Type L	Type LX
1,475 - 1,525	1,360	V-1500L/LX	TWVLW1500	TWLXW1500
1,525 - 1,575	1,405	V-1550L/LX	TWVLW1550	TWLXW1550
1,575 - 1,625	1,450	V-1600L/LX	TWVLW1600	TWLXW1600
1,625 - 1,675	1,495	V-1650L/LX	TWVLW1650	TWLXW1650
1,675 - 1,725	1,540	V-1700L/LX	TWVLW1700	TWLXW1700
1,725 - 1,775	1,585	V-1750L/LX	TWVLW1750	TWLXW1750
1,775 - 1,825	1,630	V-1800L/LX	TWVLW1800	TWLXW1800
1,825 - 1,875	1,675	V-1850L/LX	TWVLW1850	TWLXW1850
1,875 - 1,925	1,720	V-1900L/LX	TWVLW1900	TWLXW1900
1,925 - 1,975	1,765	V-1950L/LX	TWVLW1950	TWLXW1950
1,975 - 2,025	1,810	V-2000L/LX	TWVLW2000	TWLXW2000

V-Ring L or LX for a shaft size larger than 2,020 mm can be made to special order.



V-Ring Type RM/RME

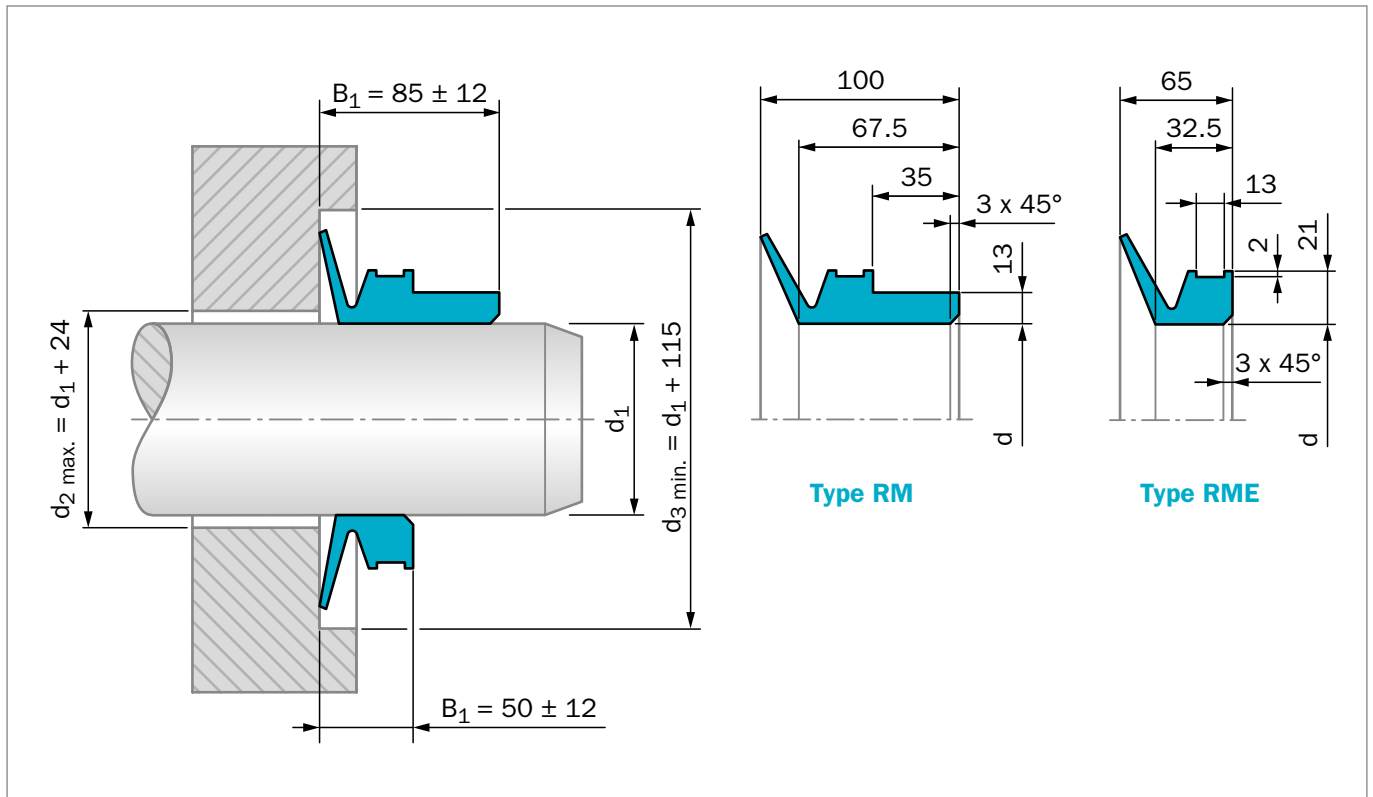

Figure 79: Installation Drawing

When the dimension d_1 is on the boundary between two sizes of V-Ring, select the larger V-Ring. All dimensions in mm.

ORDERING EXAMPLES

Type:	RME, for clamping band, butt-vulcanized for shaft diameter = 500.0 mm
Material:	N6T50 (Nitrile Elastomer)

Type:	RM, for clamping band, butt-vulcanized for shaft diameter = 500.0 mm
Material:	N6T50 (Nitrile Elastomer)

TSS Article No.	TWVBV5000 - N6T50
TSS Part No.	_____
Quality Index (Standard)	_____
Material No. (Standard)	_____

TSS Article No.	TWRMV5000 - N6T50
TSS Part No.	_____
Quality Index (Standard)	_____
Material No. (Standard)	_____



Table 54: Profile Dimensions – Assembly Dimensions

For Shaft Diameter d_1	Inside Diameter d	V-Ring FORSHEDA Ref.	TSS Part No.	TSS Part No.
			Type RM	Type RME
300 - 305	294	V-300RM/RME	TWRMV3000	TWVBV3000
305 - 310	299	V-305RM/RME	TWRMV3050	TWVBV3050
310 - 315	304	V-310RM/RME	TWRMV3100	TWVBV3100
315 - 320	309	V-315RM/RME	TWRMV3150	TWVBV3150
320 - 325	314	V-320RM/RME	TWRMV3200	TWVBV3200
325 - 330	319	V-325RM/RME	TWRMV3250	TWVBV3250
330 - 335	323	V-330RM/RME	TWRMV3300	TWVBV3300
335 - 340	328	V-335RM/RME	TWRMV3350	TWVBV3350
345 - 350	338	V-345RM/RME	TWRMV3450	TWVBV3450
350 - 355	343	V-350RM/RME	TWRMV3500	TWVBV3500
355 - 360	347	V-355RM/RME	TWRMV3550	TWVBV3550
360 - 365	352	V-360RM/RME	TWRMV3600	TWVBV3600
365 - 370	357	V-365RM/RME	TWRMV3650	TWVBV3650
370 - 375	362	V-370RM/RME	TWRMV3700	TWVBV3700
375 - 380	367	V-375RM/RME	TWRMV3750	TWVBV3750
380 - 385	371	V-380RM/RME	TWRMV3800	TWVBV3800
385 - 390	376	V-385RM/RME	TWRMV3850	TWVBV3850
390 - 395	381	V-390RM/RME	TWRMV3900	TWVBV3900
395 - 400	386	V-395RM/RME	TWRMV3950	TWVBV3950
400 - 405	391	V-400RM/RME	TWRMV4000	TWVBV4000
405 - 410	396	V-405RM/RME	TWRMV4050	TWVBV4050
410 - 415	401	V-410RM/RME	TWRMV4100	TWVBV4100
415 - 420	405	V-415RM/RME	TWRMV4150	TWVBV4150
420 - 425	410	V-420RM/RME	TWRMV4200	TWVBV4200
425 - 430	415	V-425RM/RME	TWRMV4250	TWVBV4250
430 - 435	420	V-430RM/RME	TWRMV4300	TWVBV4300
435 - 440	425	V-435RM/RME	TWRMV4350	TWVBV4350
440 - 445	429	V-440RM/RME	TWRMV4400	TWVBV4400
445 - 450	434	V-445RM/RME	TWRMV4450	TWVBV4450
450 - 455	439	V-450RM/RME	TWRMV4500	TWVBV4500
455 - 460	444	V-455RM/RME	TWRMV4550	TWVBV4550
460 - 465	448	V-460RM/RME	TWRMV4600	TWVBV4600
465 - 470	453	V-465RM/RME	TWRMV4650	TWVBV4650
470 - 475	458	V-470RM/RME	TWRMV4700	TWVBV4700
475 - 480	463	V-475RM/RME	TWRMV4750	TWVBV4750
480 - 485	468	V-480RM/RME	TWRMV4800	TWVBV4800
485 - 490	473	V-485RM/RME	TWRMV4850	TWVBV4850
490 - 495	478	V-490RM/RME	TWRMV4900	TWVBV4900
495 - 500	483	V-495RM/RME	TWRMV4950	TWVBV4950
500 - 505	488	V-500RM/RME	TWRMV5000	TWVBV5000
505 - 510	493	V-505RM/RME	TWRMV5050	TWVBV5050
510 - 515	497	V-510RM/RME	TWRMV5100	TWVBV5100
515 - 520	502	V-515RM/RME	TWRMV5150	TWVBV5150



For Shaft Diameter	Inside Diameter	V-Ring	TSS Part No.	TSS Part No.
d_1	d	FORSHEDA Ref.	Type RM	Type RME
520 - 525	507	V-520RM/RME	TWRMV5200	TWVBV5200
525 - 530	512	V-525RM/RME	TWRMV5250	TWVBV5250
530 - 535	517	V-530RM/RME	TWRMV5300	TWVBV5300
535 - 540	521	V-535RM/RME	TWRMV5350	TWVBV5350
540 - 545	526	V-540RM/RME	TWRMV5400	TWVBV5400
545 - 550	531	V-545RM/RME	TWRMV5450	TWVBV5450
550 - 555	536	V-550RM/RME	TWRMV5500	TWVBV5500
555 - 560	541	V-555RM/RME	TWRMV5550	TWVBV5550
560 - 565	546	V-560RM/RME	TWRM05600	TWVB05600
565 - 570	550	V-565RM/RME	TWRMV5650	TWVBV5650
570 - 575	555	V-570RM/RME	TWRMV5700	TWVBV5700
575 - 580	560	V-575RM/RME	TWRMV5750	TWVBV5750
580 - 585	565	V-580RM/RME	TWRMV5800	TWVBV5800
585 - 590	570	V-585RM/RME	TWRMV5850	TWVBV5850
590 - 600	575	V-590RM/RME	TWRMV5900	TWVBV5900
600 - 610	582	V-600RM/RME	TWRMV6000	TWVBV6000
610 - 620	592	V-610RM/RME	TWRMV6100	TWVBV6100
620 - 630	602	V-620RM/RME	TWRMV6200	TWVBV6200
630 - 640	612	V-630RM/RME	TWRMV6300	TWVBV6300
640 - 650	621	V-640RM/RME	TWRMV6400	TWVBV6400
650 - 660	631	V-650RM/RME	TWRMV6500	TWVBV6500
660 - 670	640	V-660RM/RME	TWRMV6600	TWVBV6600
670 - 680	650	V-670RM/RME	TWRMV6700	TWVBV6700
680 - 690	660	V-680RM/RME	TWRMV6800	TWVBV6800
690 - 700	670	V-690RM/RME	TWRMV6900	TWVBV6900
700 - 710	680	V-700RM/RME	TWRMV7000	TWVBV7000
710 - 720	689	V-710RM/RME	TWRMV7100	TWVBV7100
720 - 730	699	V-720RM/RME	TWRMV7200	TWVBV7200
730 - 740	709	V-730RM/RME	TWRMV7300	TWVBV7300
740 - 750	718	V-740RM/RME	TWRMV7400	TWVBV7400
750 - 758	728	V-750RM/RME	TWRMV7500	TWVBV7500
758 - 766	735	V-760RM/RME	TWRMV7600	TWVBV7600
766 - 774	743	V-770RM/RME	TWRMV7700	TWVBV7700
774 - 783	751	V-780RM/RME	TWRMV7800	TWVBV7800
783 - 792	759	V-790RM/RME	TWRMV7900	TWVBV7900
792 - 801	768	V-800RM/RME	TWRMV8000	TWVBV8000
801 - 810	777	V-810RM/RME	TWRMV8100	TWVBV8100
810 - 821	786	V-820RM/RME	TWRMV8200	TWVBV8200
821 - 831	796	V-830RM/RME	TWRMV8300	TWVBV8300
831 - 841	805	V-840RM/RME	TWRMV8400	TWVBV8400
841 - 851	814	V-850RM/RME	TWRMV8500	TWVBV8500
851 - 861	824	V-860RM/RME	TWRMV8600	TWVBV8600
861 - 871	833	V-870RM/RME	TWRMV8700	TWVBV8700



For Shaft Diameter	Inside Diameter	V-Ring	TSS Part No.	TSS Part No.
d ₁	d	FORSHEDA Ref.	Type RM	Type RME
871 - 882	843	V-880RM/RME	TWRMV8800	TWVBV8800
882 - 892	853	V-890RM/RME	TWRMV8900	TWVBV8900
892 - 912	871	V-900RM/RME	TWRMV9000	TWVBV9000
912 - 922	880	V-920RM/RME	TWRMV9200	TWVBV9200
922 - 933	890	V-930RM/RME	TWRMV9300	TWVBV9300
933 - 944	900	V-940RM/RME	TWRMV9400	TWVBV9400
944 - 955	911	V-950RM/RME	TWRMV9500	TWVBV9500
955 - 966	921	V-960RM/RME	TWRMV9600	TWVBV9600
966 - 977	932	V-970RM/RME	TWRMV9700	TWVBV9700
977 - 988	942	V-980RM/RME	TWRMV9800	TWVBV9800
988 - 999	953	V-990RM/RME	TWRMV9900	TWVBV9900
999 - 1,010	963	V-1000RM/RME	TWRMW1000	TWVBW1000
1,010 - 1,025	973	V-1020RM/RME	TWRMW1020	TWVBW1020
1,025 - 1,045	990	V-1040RM/RME	TWRMW1040	TWVBW1040
1,045 - 1,065	1,008	V-1060RM/RME	TWRMW1060	TWVBW1060
1,065 - 1,085	1,027	V-1080RM/RME	TWRMW1080	TWVBW1080
1,085 - 1,105	1,045	V-1100RM/RME	TWRM01100	TWVB01100
1,105 - 1,125	1,065	V-1120RM/RME	TWRMW1120	TWVBW1120
1,125 - 1,145	1,084	V-1140RM/RME	TWRMW1140	TWVBW1140
1,145 - 1,165	1,103	V-1160RM/RME	TWRMW1160	TWVBW1160
1,165 - 1,185	1,121	V-1180RM/RME	TWRMW1180	TWVBW1180
1,185 - 1,205	1,139	V-1200RM/RME	TWRMW1200	TWVBW1200
1,205 - 1,225	1,157	V-1220RM/RME	TWRMW1220	TWVBW1220
1,225 - 1,245	1,176	V-1240RM/RME	TWRMW1240	TWVBW1240
1,245 - 1,270	1,195	V-1260RM/RME	TWRMW1260	TWVBW1260
1,270 - 1,295	1,218	V-1280RM/RME	TWRMW1280	TWVBW1280
1,295 - 1,315	1,240	V-1300RM/RME	TWRMW1300	TWVBW1300
1,315 - 1,340	1,259	V-1325RM/RME	TWRMW1325	TWVBW1325
1,340 - 1,365	1,281	V-1350RM/RME	TWRMW1350	TWVBW1350
1,365 - 1,390	1,305	V-1375RM/RME	TWRMW1375	TWVBW1375
1,390 - 1,415	1,328	V-1400RM/RME	TWRMW1400	TWVBW1400
1,415 - 1,440	1,350	V-1425RM/RME	TWRMW1425	TWVBW1425
1,440 - 1,465	1,374	V-1450RM/RME	TWRMW1450	TWVBW1450
1,465 - 1,490	1,397	V-1475RM/RME	TWRMW1475	TWVBW1475
1,490 - 1,515	1,419	V-1500RM/RME	TWRMW1500	TWVBW1500
1,515 - 1,540	1,443	V-1525RM/RME	TWRMW1525	TWVBW1525
1,540 - 1,570	1,467	V-1550RM/RME	TWRMW1550	TWVBW1550
1,570 - 1,600	1,495	V-1575RM/RME	TWRMW1575	TWVBW1575
1,600 - 1,640	1,524	V-1600RM/RME	TWRMW1600	TWVBW1600
1,640 - 1,680	1,559	V-1650RM/RME	TWRMW1650	TWVBW1650
1,680 - 1,720	1,596	V-1700RM/RME	TWRMW1700	TWVBW1700
1,720 - 1,765	1,632	V-1750RM/RME	TWRMW1750	TWVBW1750
1,765 - 1,810	1,671	V-1800RM/RME	TWRMW1800	TWVBW1800



For Shaft Diameter	Inside Diameter	V-Ring	TSS Part No.	TSS Part No.
d_1	d	FORSHEDA Ref.	Type RM	Type RME
1,810 - 1,855	1,714	V-1850RM/RME	TWRMW1850	TWVBW1850
1,855 - 1,905	1,753	V-1900RM/RME	TWRMW1900	TWVBW1900
1,905 - 1,955	1,794	V-1950RM/RME	TWRMW1950	TWVBW1950
1,955 - 2,010	1,844	V-2000RM/RME	TWRMW2000	TWVBW2000

V-Ring RM or RME for a shaft size larger than 2,010 mm can be made to special order.



V-Ring Type AX

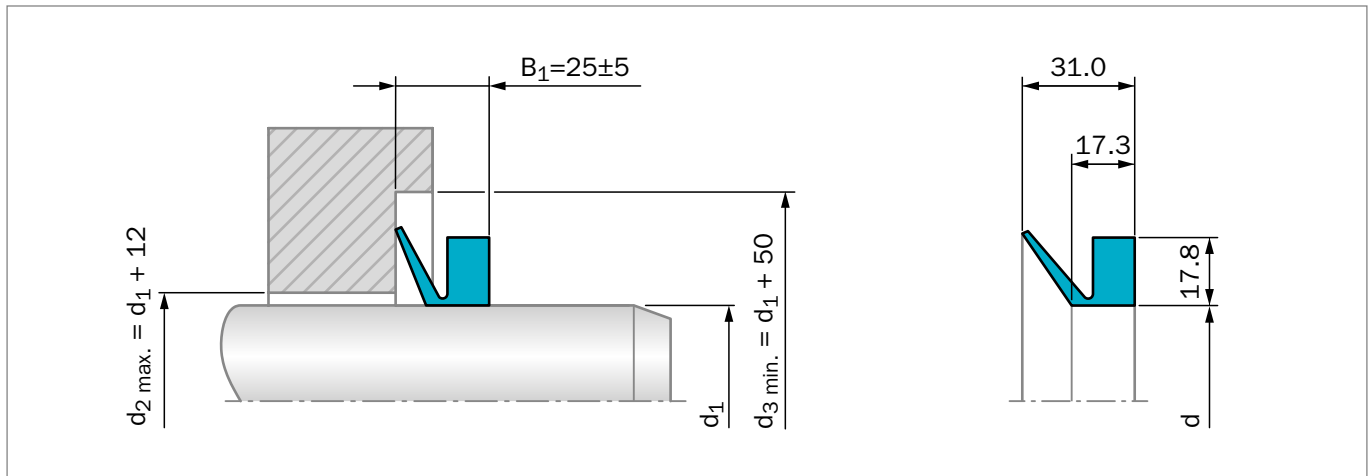

Figure 80: Installation Drawing

When the dimension d_1 is on the boundary between two sizes of V-Ring, select the larger V-Ring. All dimensions in mm.

ORDERING EXAMPLE

Type:	AX, for shaft diameter = 1190 mm
Material:	N6T50 (Nitrile Elastomer)

TSS Article No.	TWAXW1200 - N6T50
TSS Part No.	_____
Quality Index (Standard)	_____
Material No. (Standard)	_____

Table 55: Profile Dimensions – Assembly Dimensions

For Shaft Diameter d_1	Inside Diameter d	V-Ring FORSHEDA Ref.	TSS Part No.
200 - 205	192	V-200AX	TWAXV2000
205 - 210	196	V-205AX	TWAXV2050
210 - 215	200	V-210AX	TWAXV2100
215 - 219	204	V-215AX	TWAXV2150
219 - 224	207	V-220AX	TWAXV2200
224 - 228	211	V-225AX	TWAXV2250
228 - 232	215	V-230AX	TWAXV2300
232 - 236	219	V-235AX	TWAXV2350
236 - 240	223	V-240AX	TWAXV2400
240 - 250	227	V-250AX	TWAXV2500
250 - 260	236	V-260AX	TWAXV2600
260 - 270	245	V-270AX	TWAXV2700
270 - 281	255	V-280AX	TWAXV2800
281 - 292	265	V-290AX	TWAXV2900
292 - 303	275	V-300AX	TWAXV3000
303 - 313	285	V-310AX	TWAXV3100
313 - 325	295	V-320AX	TWAXV3200



For Shaft Diameter	Inside Diameter	V-Ring	TSS Part No.
d_1	d	FORSHEDA Ref.	
325 - 335	305	V-330AX	TWAXV3300
335 - 345	315	V-340AX	TWAXV3400
345 - 355	322	V-350AX	TWAXV3500
355 - 372	328	V-360AX	TWAXV3600
372 - 390	344	V-380AX	TWAXV3800
390 - 415	360	V-400AX	TWAXV4000
415 - 443	385	V-425AX	TWAXO4250
443 - 480	410	V-450AX	TWAXV4500
480 - 530	450	V-500AX	TWAXV5000
530 - 580	495	V-550AX	TWAXV5500
580 - 630	540	V-600AX	TWAXV6000
630 - 665	600	V-650AX	TWAXO6500
665 - 705	630	V-700AX	TWAXV7000
705 - 745	670	V-725AX	TWAXV7250
745 - 785	705	V-750AX	TWAXV7500
785 - 830	745	V-800AX	TWAXV8000
830 - 875	785	V-850AX	TWAXV8500
875 - 920	825	V-900AX	TWAXV9000
920 - 965	865	V-950AX	TWAXV9500
965 - 1,015	910	V-1000AX	TWAXW1000
1,015 - 1,065	955	V-1050AX	TWAXX1050
1,065 - 1,115	1,000	V-1100AX	TWAXW1100
1,115 - 1,165	1,045	V-1150AX	TWAXW1150
1,165 - 1,215	1,090	V-1200AX	TWAXW1200
1,215 - 1,270	1,135	V-1250AX	TWAXW1250
1,270 - 1,320	1,180	V-1300AX	TWAXW1300
1,320 - 1,370	1,225	V-1350AX	TWAXW1350
1,370 - 1,420	1,270	V-1400AX	TWAXW1400
1,420 - 1,470	1,315	V-1450AX	TWAXW1450
1,470 - 1,520	1,360	V-1500AX	TWAXW1500
1,520 - 1,570	1,405	V-1550AX	TWAXW1550
1,570 - 1,620	1,450	V-1600AX	TWAXW1600
1,620 - 1,670	1,495	V-1650AX	TWAXW1650
1,670 - 1,720	1,540	V-1700AX	TWAXW1700
1,720 - 1,770	1,585	V-1750AX	TWAXW1750
1,770 - 1,820	1,630	V-1800AX	TWAXW1800
1,820 - 1,870	1,675	V-1850AX	TWAXW1850
1,870 - 1,920	1,720	V-1900AX	TWAXW1900
1,920 - 1,970	1,765	V-1950AX	TWAXW1950
1,970 - 2,020	1,810	V-2000AX	TWAXW2000

V-Ring AX for a shaft size larger than 2,020 mm can be made to special order.

GAMMA Seal







■ Gamma Seal

■ General Description

The GAMMA seal is the result of a large-scale development project covering many years of attempts to combine the capability of conventional mechanical seals to operate at high speeds with the simplicity of the Rotary Shaft Lip Seal. Figure 87 shows the different types, which are characterized by simple design. The basic design consists of two parts, sealing element and metal case. The GAMMA seal is designed to be fixed to the shaft at a pre-determined distance from the sealing surface, which is positioned perpendicularly to the shaft, for example the end wall of a bearing housing. During rotation, the sealing lip rubs against the counter face under a contact pressure calculated to achieve a sealing function. The seal also operates as a deflector ring, and its centrifugal action contributes to good sealing function. Due to the effect of centrifugal force, the sealing lip tends to reduce its contact pressure with increasing speed. As a result, the curve for power loss is very favorable (see Figure 82). At a peripheral speed of around 12 m/s, friction losses begin to diminish and cease completely at about 20 m/s, when the sealing lip has completely lifted free of counter faces. The GAMMA seal then functions as a combined deflector ring and clearance seal.

The GAMMA seal is primarily intended for sealing against foreign matter, liquid splatter, grease.

The foremost features of the GAMMA seal are:

- Very narrow installation width
- Friction diminishes with increasing rotational speed
- Centrifugal action contributes to good sealing
- Lower demands on surface smoothness, surface hardness and tolerances
- Mechanical protection
- Easy to fit

GENERAL DESIGN PARAMETERS

The GAMMA seal permits simple installation design and the requirements on the surface against which the sealing lip works are low. A finish-turned, polished surface with a roughness of 3 - 5 $\mu\text{m Ra}$ is normally adequate. However, the character of the surface is of greater importance than the action surface roughness value. Surface profiles with sharp peaks must be avoided. Injection-molded light-metal alloys can be used in counter faces without further machining. It is necessary to ensure, however, that the part of the mould that produces the counter face is absolutely flawless.

Cold-rolled steel sheet, stainless or zinc plated sheet are excellent materials for counter faces for GAMMA seal. In comparison to other types of seals, the GAMMA seal can better absorb a certain amount of shaft misalignment. It is also relatively insensitive to shaft-to-bore eccentricity and shaft run-out.

Directions of shaft design and fitting are provided in the following sections on GAMMA seal types TBP/RB and TBR/9RB.

GAMMA SEAL TYPE TBP/RB AND TBR/9RB

GAMMA seal type TPB/RB and TBR/9RB consists of an elastic sealing element and a metal case (see Figure 81). The case serves as a holder, support and protection for the sealing element and constitutes a very effective deflector. The components are not bonded to each other, the rubber-sealing element is stretched and held in the case by its elasticity.

Type TBP/RB and TBR/9RB provide a very narrow installation width, which has proved to be very advantageous in certain applications and has permitted this seal to be used in assemblies where other seals could not previously be installed due to lack of space. The seal is press fitted on the shaft, and no other means of fixing is required.

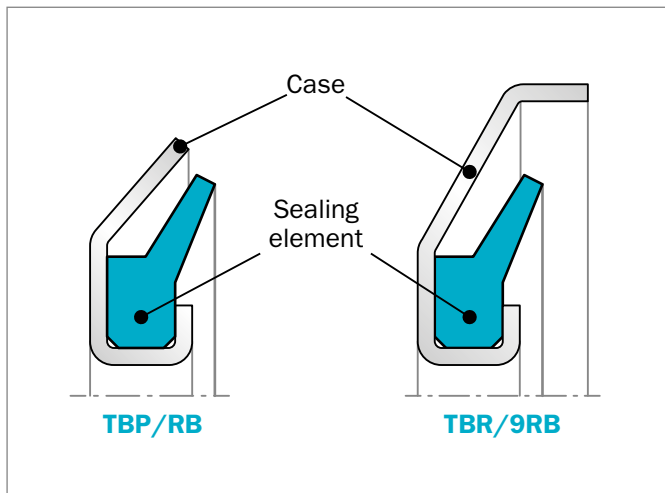

Figure 81: GAMMA seal types

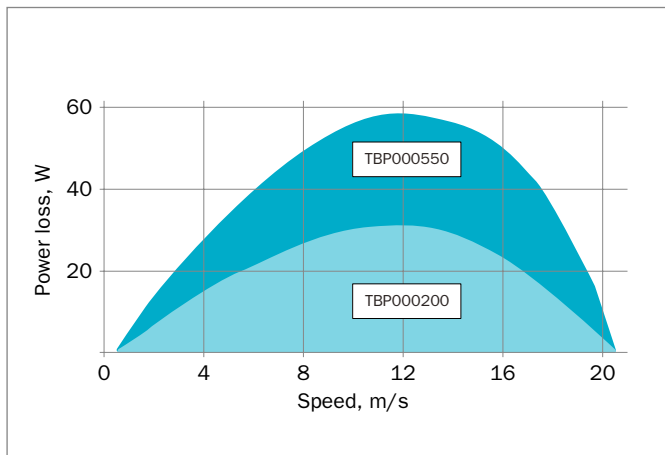

Figure 82: Power loss as a function of peripheral speed
(Counterface 1.5 - 2 μm Ra not lubricated seal)

MANUFACTURING MATERIALS

The sealing element is molded and is normally made of Nitrile rubber with a hardness of 75 ± 5 IRHD. Other compounds can be supplied on request. The case is stamped of cold-rolled steel sheet. In order to ensure a good seal and a tight grip on the shaft, the inside diameter is machined to dimensions which ensure a suitable press fit. The tolerances for the inside diameter of the case are given in Table 56. The case is normally zinc plated. The case can also be made out of other materials, such as, stainless steel.

INSTALLATION DESIGN

GAMMA seal type TBP should normally be installed as shown in Figure 84, i.e. with the seal located in the medium which it is to seal against. As shown in Figure 88 the counter face for type TBR against which the sealing lip works should be designed with a groove for the case extension in order to create the clearance seal. For vertical shafts a design in accordance with Figure 83 is preferred, which effectively will reject impurities and liquid splatter. Shaft tolerance ISO h9 provides a suitable press fit. The shaft tolerances normally used for ball and roller bearings, ISO g6 to n6, can also be used. The seal does not require any other axial fixing other than that which is obtained by the press fit between the case and the shaft.

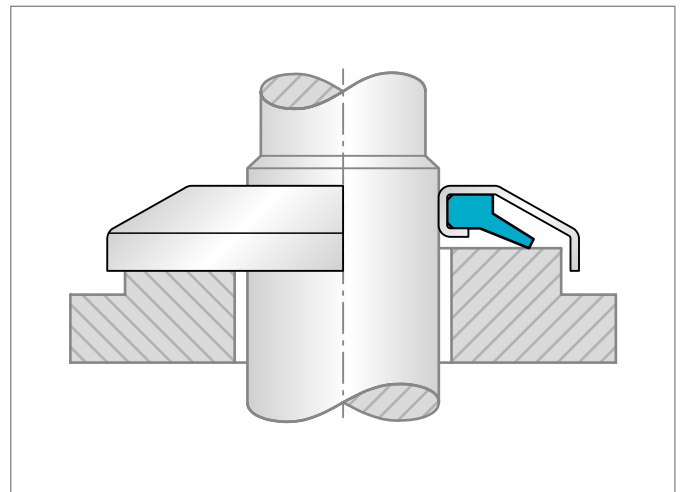

Figure 83: Vertical installation

However, providing a shoulder or a circlip to position the ring may facilitate fitting. The installation dimensions are given in the dimension table.

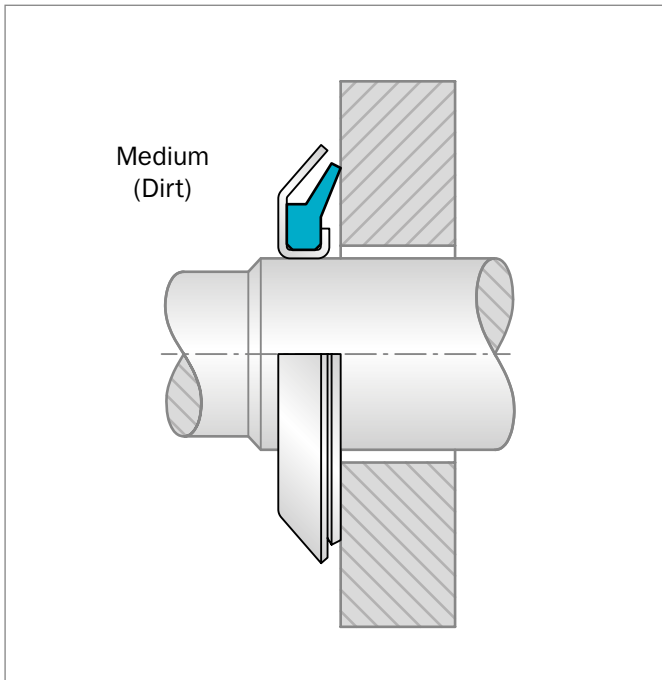

Figure 84: Installation Drawing

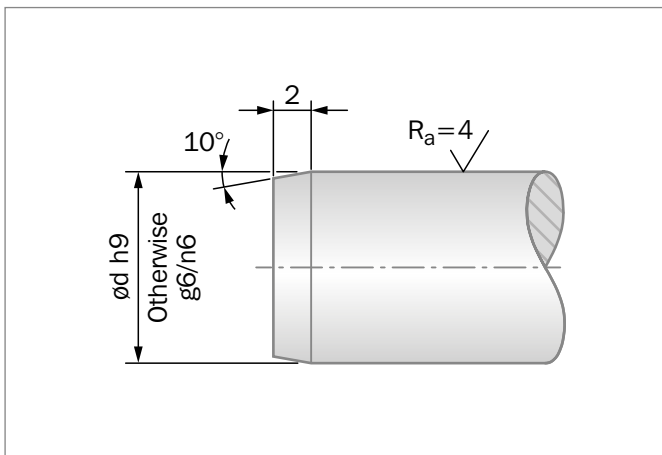

Figure 85: Tolerance of the shaft, surface roughness and chamfer of the shaft

The surface roughness of the shaft should not exceed $4 \mu\text{m}$ R_a . In addition, the shaft should be provided with a chamfer as per Figure 85. Sharp edges or burrs are not permitted. In the case of width b , a variation of $+0.5 \text{ mm}$ is permissible.

Table 56: Lead-in Chamfers

Inside Diameter mm	Chamfer mm	Tolerance mm
0 - 35	2	-0.15 -0.25
36 - 50	2	-0.18 -0.28
51 - 135	2	-0.20 -0.30
136 - 200	2	-0.25 -0.35

FITTING

Prior to being fitted, the sealing member shall be greased, but not between the sealing member and the case. It is important that the seal is fitted with adequate precision. The seal shall be pressed onto the shaft with a uniform and even pressure.

The case must not be tapped directly with the hammer. The seal should therefore be pressed to the right position by means of a suitable assembly tool (see Figure 86, Figure 87 and Figure 88). Since facial fixing beyond the press fit between the seal and the shaft is not provided, the assembly tool should be of a design as shown in Figure 86 and Figure 88 in order to obtain the installation width b as per the dimension tables.

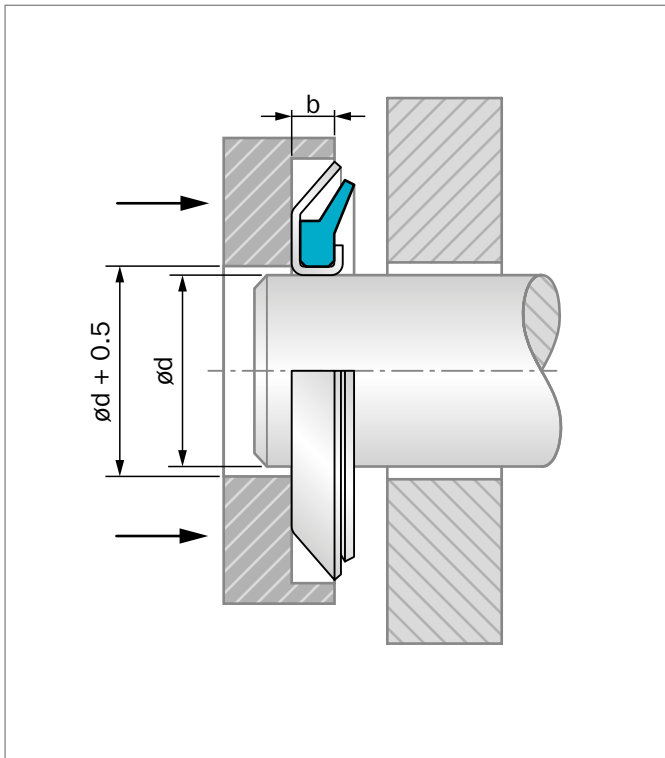

Figure 86: Assembly tool for TBP/RB

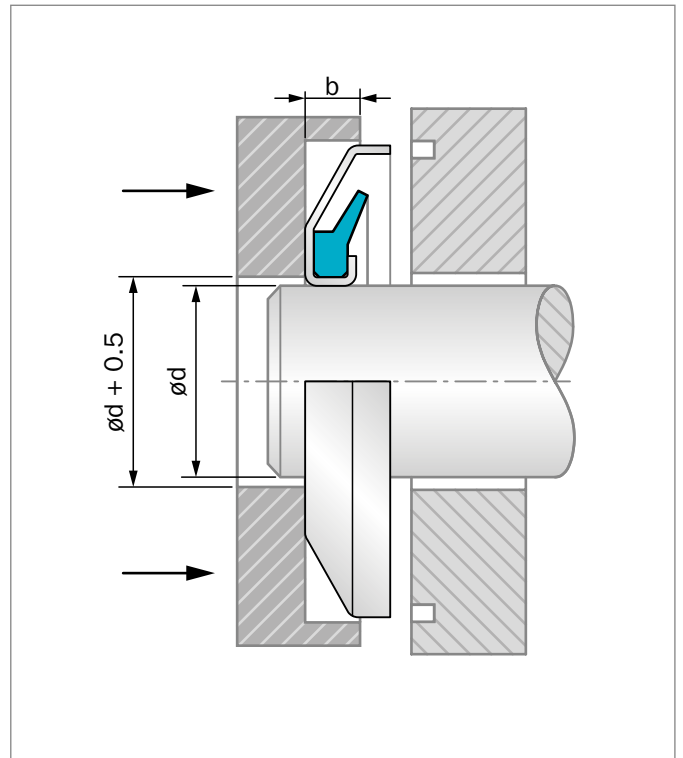

Figure 88: Assembly tool TBR/9RB

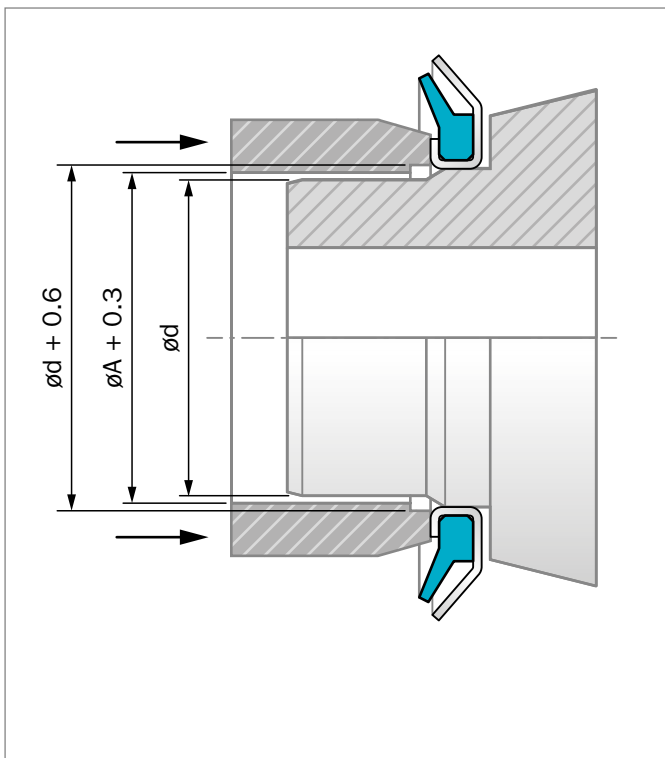

Figure 87: Assembly tool. When positioning the GAMMA seal against a shoulder it is important not to deform the case by pressing with too high load.



■ Type TBP/RB

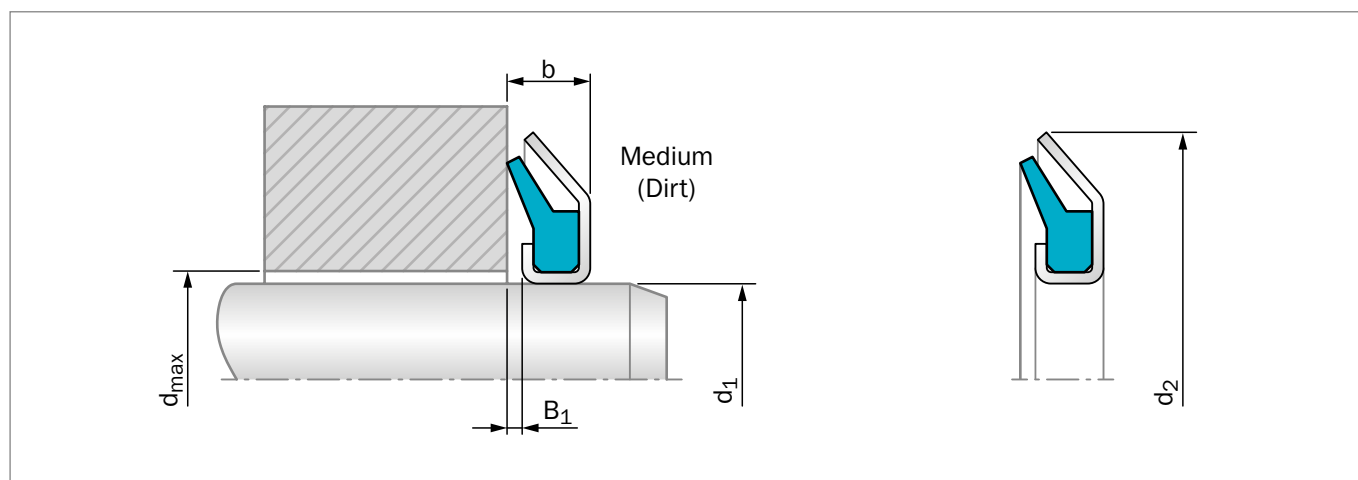

Figure 89: Installation Drawing

GENERAL DESCRIPTION

The design of most commonly used GAMMA Seal TBP/RB is based on many years of experience in such applications. The total axial force of the sealing lip is given by elastomer pre-stretching together with lip deformation force which depends on the elasticity of the rubber material, geometry of the sealing lip and assembly positioning against the counter-face. The metal shell is protecting the seal from solids and contributes to exclude other pollution media by centrifusion, allowing a good drainage after immersion in liquids.

ADVANTAGES

- Good dynamic sealing
- Very good protection against solid pollution particles
- Modern lip design provides low axial forces (low power loss)
- Small fitting width
- No supplementary retention's needed

APPLICATION EXAMPLES

- Transmission systems (e.g. gearboxes)
- Pumps
- Electrical motors
- Machine tools
- Wheels and heavy-duty axles

OPERATING CONDITIONS

Pressure:	No pressure
Temperature:	-40 °C to +200 °C depending on material
Speed:	Up to 20 m/s
Media:	Mineral and synthetic lubricants (CLP, HLP, APGL etc.)
Housing:	Carbon steel - chromate treated (N7MM) or zinc plated (4N04, 4V04) Stainless and acid-proof steel on request

Trelleborg Sealing Solutions has carried out several thousands compatibility tests. Please ask your local Trelleborg Sealing Solutions marketing company for details.

IMPORTANT NOTE

The above data are maximum values and cannot be used at the same time, e. g. the maximum operating speed depends on material type, pressure and temperature.



Table 57: Materials

Standard Material*	TSS Material Code	STEFA Material Reference	Standard Metal Shell**
NBR (70 Shore A)	N7MM	-	Carbon steel (chromated)
NBR (75 Shore A)	4N04	1452	Carbon steel (zinc plated)
FKM (75 Shore A)	4V04	5466	Carbon steel (zinc plated)

* Special grades and other materials (HNBR, ACM, VMQ) on request.
 ** Metal shell can be supplied in different material or treatment on request.

ORDERING EXAMPLE GAMMA SEAL TSS TYPE

TSS type:	BP		
Code:	TBP		
Dimensions:	Shaft diameter	25 mm	
	Housing diameter	40 mm	
	Width	4 mm	
Material:	NBR		
Material Code:	N7MM		

ORDERING EXAMPLE GAMMA SEAL STEFA TYPE

STEFA type:	RB		
Code:	TBP		
Dimensions:	Shaft diameter	25 mm	
	Housing diameter	40 mm	
	Width	4 mm	
Material:	NBR 1452		
Material Code:	4N04		

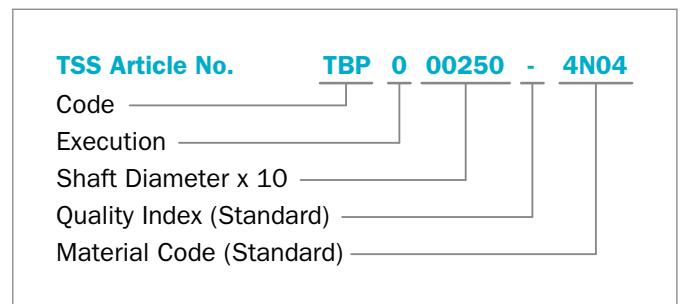
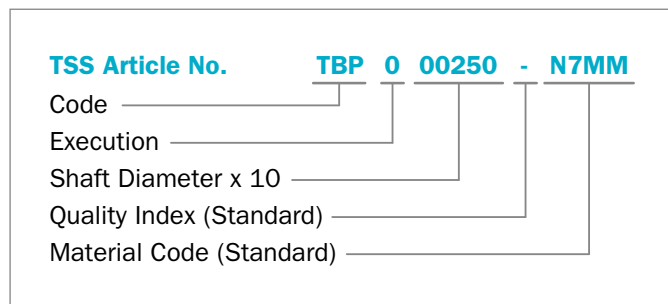

Table 58: Preferred Series / Dimension, TSS Part Numbers

Dimension					TSS Part No.	Type	STEFA		TSS
d ₁	d ₂	b	B ₁	d _{max}			NBR 4N04	FKM 4V04	NBR N7MM
10	24	3.5	1.0	15	TBP000100	RB10	●	●	
12	26	3.5	1.0	17	TBP000120	RB12	●	●	
15	30	4	1.0	21	TBP000150	RB15	●	●	●
16	32	4	1.0	23	TBP000160	RB16	●	●	●
17	32	4	1.0	23	TBP000170	RB17	●	●	●
18	33	4	1.0	24	TBP000180	RB18	●	●	●
20	35	4	1.0	26	TBP000200	RB20	●	●	●
22	40	4	1.0	28	TBP000220	RB22	●	●	●
24	40	4	1.0	30	TBP000240	RB24	●	●	●
25	40	4	1.0	31	TBP000250	RB25	●	●	●
26	40	4	1.0	32	TBP000260	RB26	●	●	
28	43	4	1.0	34	TBP000280	RB28	●	●	●
30	47	4.5	1.0	37	TBP000300	RB30	●	●	●



Dimension					TSS Part No.	STEFA			TSS
d ₁	d ₂	b	B ₁	d _{max}		Type	NBR 4N04	FKM 4V04	NBR N7MM
32	49	4.5	1.0	39	TBP000320	RB32	●	●	
35	52	4.5	1.0	42	TBP000350	RB35	●	●	●
40	57	4.5	1.0	47	TBP000400	RB40	●	●	●
45	62	4.5	1.0	52	TBP000450	RB45	●	●	●
48	65	4.5	1.0	55	TBP000480	RB48	●	●	
50	70	5.5	1.0	58	TBP000500	RB50	●	●	●
52	72	5.5	1.0	60	TBP000520	RB52	●	●	
53	73	5.5	1.0	61	TBP000530	RB53	●	●	
55	75	5.5	1.0	63	TBP000550	RB55	●	●	●
58	78	5.5	1.0	66	TBP000580	RB58	●	●	
60	80	5.5	1.0	68	TBP000600	RB60	●	●	●
62	82	5.5	1.0	70	TBP000620	RB62	●	●	
65	85	5.5	1.0	73	TBP000650	RB65	●	●	●
68	88	5.5	1.0	76	TBP000680	RB68	●	●	
70	90	5.5	1.0	78	TBP000700	RB70	●	●	●
72	92	5.5	1.0	80	TBP000720	RB72	●	●	
75	95	5.5	1.0	83	TBP000750	RB75	●	●	●
78	98	5.5	1.0	86	TBP000780	RB78	●	●	
80	100	5.5	1.0	88	TBP000800	RB80	●	●	●
85	105	5.5	1.0	93	TBP000850	RB85	●	●	●
90	110	5.5	1.0	98	TBP000900	RB90	●	●	
95	115	5.5	1.0	103	TBP000950	RB95	●	●	
100	120	5.5	1.0	108	TBP001000	RB100	●	●	●
105	125	5.5	1.0	113	TBP001050	RB105	●	●	
125	148	6.5	1.0	133	TBP001250	RB125	●	●	
135	159	6.5	1.0	145	TBP001350	RB135	●	●	



■ Type TBR/9RB

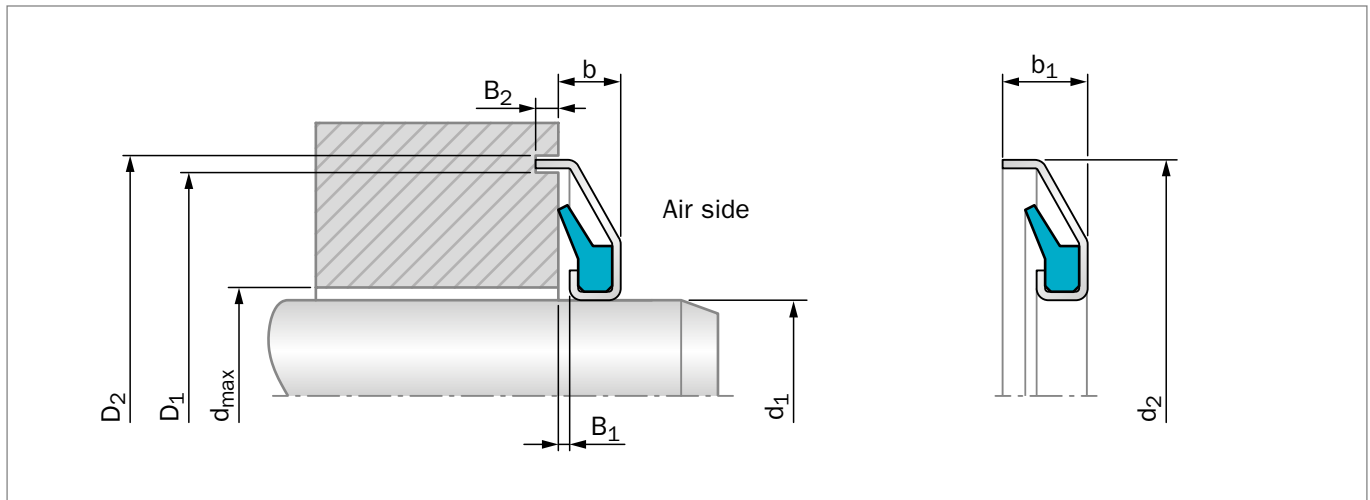

Figure 90: GAMMA seal with labyrinth

GENERAL DESCRIPTION

The design of the GAMMA seal TBR/9RB is based on many years of experience in such applications. The total axial force of the sealing lip is given by elastomer pre-stretching together with lip deformation force which depends on the elasticity of the rubber material, geometry of the sealing lip and assembly positioning against the counterface. The metal shell is protecting the seal from solids and contributes to exclude other pollution media by centrifusion, allowing a good drainage after immersion in liquids. The shape of the metal shell allows a supplementary barrier via the labyrinth in the housing groove which is very effective for heavy-duty applications.

ADVANTAGES

- Good dynamic sealing
- Very good protection against solid pollution particles
- Modern lip design provides low axial forces (low power loss)
- Small fitting width
- No supplementary retention's needed
- Very effective supplementary labyrinth protection

APPLICATION EXAMPLES

- Transmission systems (e.g. gearboxes)
- Pumps
- Electrical motors - mixers
- Machine tools
- Wheels and heavy-duty axles

OPERATING CONDITIONS

Pressure:	No pressure
Temperature:	-40 °C to +200 °C depending on material
Media:	Mineral and synthetic lubricants (CLP, HLP, APGL etc.)
Housing:	Carbon steel - zinc plated Stainless and acid-proof steel on request

Trelleborg Sealing Solutions has carried out several thousands compatibility tests. Please ask your local Trelleborg Sealing Solutions marketing company for details.

IMPORTANT NOTE

The above data are maximum values and cannot be used at the same time, e. g. the maximum operating speed depends on material type, pressure and temperature.

**Table 59: Materials**

Standard Material*	TSS Material Code	STEFA Material Reference	Standard Metal Shell**
NBR (75 Shore A)	4N04	1452	Carbon steel (zinc plated)
FKM (75 Shore A)	4V04	5466	Carbon steel (zinc plated)

* Special grades and other compounds (HNBR, ACM, VMQ) on request.

** Metal shell can be supplied in different material or treatment on request.

ORDERING EXAMPLE GAMMA SEAL STEFA TYPE

STEFA type:	9RB		
Code:	TBP		
Dimensions:	Shaft diameter	25 mm	
	Housing diameter	42 mm	
	Width	4 mm	
Material:	NBR 1452		
Material Code:	4N04		

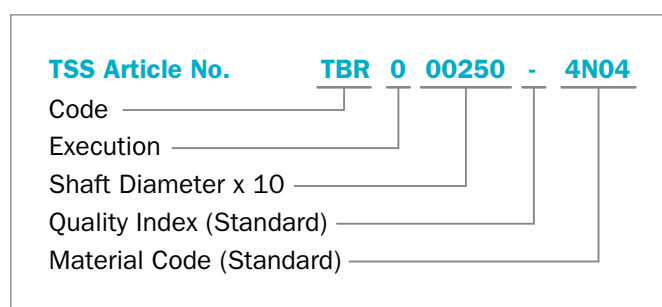
**Table 60: Preferred Series / Dimension, TSS Part Numbers**

Dimension									TSS Part No.	TSS		
d ₁	d ₂	b	B ₁	b ₁	B ₂	dmax	D ₁	D ₂		Type	NBR 4N04	FKM 4V04
15	32	4	1.0	6.0	3	21	29	34	TBR000150	9RB15	●	●
17	34	4	1.0	6.0	3	23	31	36	TBR000170	9RB17	●	●
20	37	4	1.0	6.0	3	26	34	39	TBR000200	9RB20	●	●
25	42	4	1.0	6.0	3	31	39	44	TBR000250	9RB25	●	●
30	48	4.5	1.0	6.5	3	37	45	50	TBR000300	9RB30	●	●
35	53	4.5	1.0	6.5	3	42	50	55	TBR000350	9RB35	●	●
40	58	4.5	1.0	6.5	3	47	55	60	TBR000400	9RB40	●	●
45	63	4.5	1.0	6.5	3	52	60	65	TBR000450	9RB45	●	●
55	77	5.5	1.0	7.5	3	63	73.5	79	TBR000550	9RB55	●	●
70	92	5.5	1.0	7.5	3	78	88.5	94	TBR000700	9RB70	●	●
80	102	5.5	1.0	7.5	3	88	98.5	104	TBR000800	9RB80	●	●
85	107	5.5	1.0	7.5	3	93	103.5	109	TBR000850	9RB85	●	●
90	112	5.5	1.0	7.5	3	98	108.5	114	TBR000900	9RB90	●	●
95	117	5.5	1.0	7.5	3	103	113.5	119	TBR000950	9RB95	●	●
100	122	5.5	1.0	7.5	3	108	118.5	124	TBR001000	9RB100	●	●



Turcon[®] Roto L







■ Turcon® Roto L

■ General Description



Figure 91: Turcon® Roto L

The Turcon® Roto L has been designed to cope with increasing requirements of high performance vehicle operators.

An ascending amount of vehicles incorporate a central tire inflation system, where sealing around the axle is required to increase or decrease pressure depending on the surface the vehicle is travelling on.

While conventional seals remain in contact with the axle all the time, Turcon® Roto L only seals when needed, meaning that pressure causes the sealing lip to press against the sealing surface until the pressure is relieved. In case of no activation, the jacket of the seal brings the sealing lip back to its original position, where it is just held against the sealing surface.

This leads to extended seal life as well as reduced friction and lower fuel consumption.

These features are realized through a PTFE sealing lip with a rubber jacket and a stable shape forming metal part.

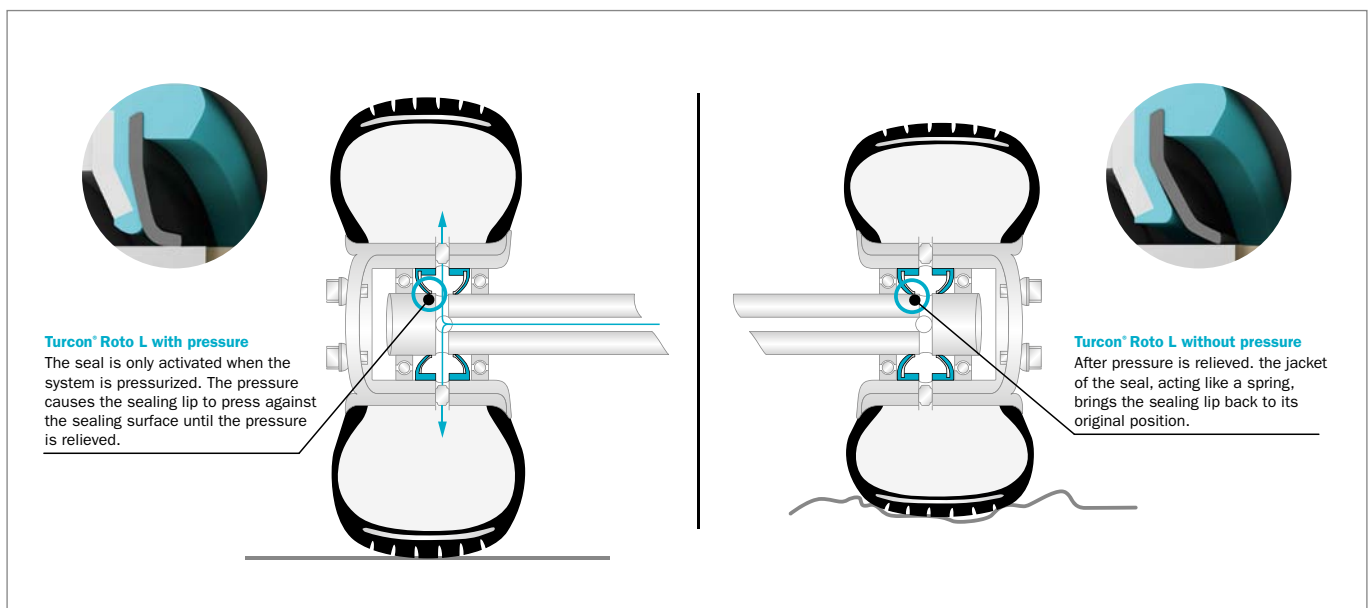

Figure 92: Functional Principle Turcon® Roto L

ADVANTAGES

- Extended seal life on axle systems due to reduced frictional torque (see fig. "Dry air torque test" and "Lifetime of hardware")
- Low friction and suited to short stroke linear movement
- Compatible with all types of hydraulic fluid, especially those fluids with low lubrication performance
- High wear resistance
- Deflation and inflation of tires on the move minimizes down time
- Lower overall vehicle operator costs

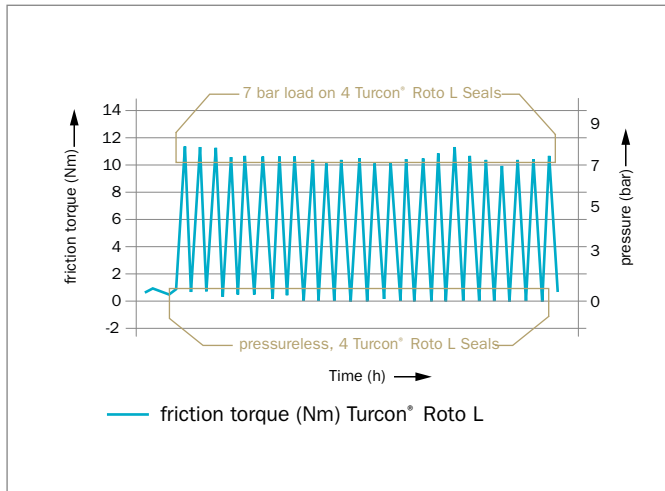

Figure 93: Dry air torque tes

APPLICATION EXAMPLES

- Rotary Applications, e.g. deflation and inflation of tires
- Axle systems
- Transmission
- On- and Off-Highway
- Trucks and Trailers
- Super sports cars

OPERATING CONDITIONS

Pressure:	Up to 0,10 MPa for standard lip profiles
Medium:	Air
Temperature:	-40 °C to +200 °C (depending on material)

Trelleborg Sealing Solutions has carried out several thousand compability tests. Please ask your local Trelleborg Sealing Solutions marketing company for details.

IMPORTANT NOTE

The above data are maximum values and cannot be used at the same time, e. g. the maximum operating speed depends on material type, pressure and temperature.

Turcon® M12 from Trelleborg Sealing Solutions is a polytetrafluoroethylene (PTFE) based sealing material whose performance is unrivaled in key hydraulic sealing characteristics, such as friction, wear and high pressure operation.

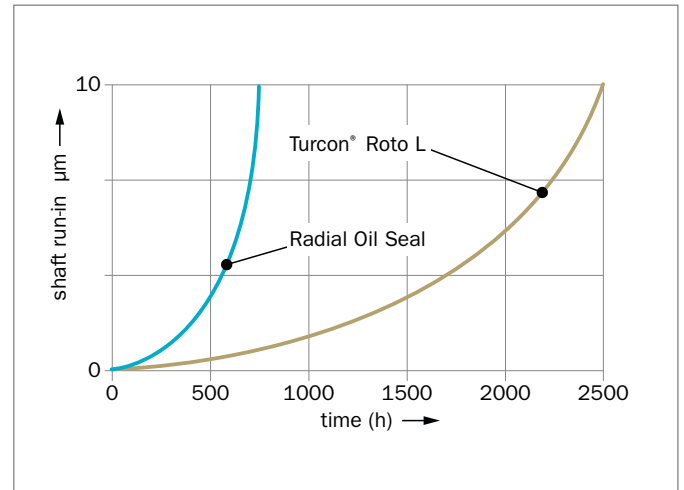

Figure 94: Lifetime of hardware

No other material can give such universally exceptional performance

Extensive testing showed that Turcon® M12 is resistant to virtually all media, including a broad range of lubricants, and has outstanding wear resistance and friction characteristics. This cost-effective material also provides customers with extended seal life, as well as wide operating window in terms of temperature, pressure and velocity. Comprehensive testing has shown that no other PTFE material can give such universally exceptional performance, and Turcon® M12 is now recommended by Trelleborg Sealing Solutions as the material of choice for a wide variety of hydraulic applications.



FEATURES AND BENEFITS OF TURCON® M12

- Resistant to virtually all media including a broad range of lubricants
- Outstanding wear resistance and friction characteristics
- Provides extended seal life
- Operates in wide temperature, pressure and velocity ranges
- Minimal abrasion of hardware, preventing damage to counter surfaces
- Robust for harsh environments
- Good resistance to extrusion
- Reduced environmental impact as it does not include bronze fillers
- Sealing material for universal use in hydraulic applications
- Lower stock holding and fewer items to handle
- Cost-effective solution

Table 61: Material combinations

Material Code new	Description
M12SH	Turcon® M12 - metal-HNBR
M12SN	Turcon® M12 - metal-NBR
M12SV	Turcon® M12 - metal-FKM
M12SA	Turcon® M12 - metal-ACM
M12ZH	Turcon® M12 - stainless steel-HNBR
M12ZN	Turcon® M12 - stainless steel-NBR
M12ZV	Turcon® M12 - stainless steel-FKM
M12ZA	Turcon® M12 - stainless steel-ACM



Turcon[®] Varilip[®] PDR







■ Turcon® Varilip® PDR

■ Introduction

Turcon® Varilip® PDR rotary shaft seals extend the boundaries imposed by elastomer radial shaft seals, utilizing advanced materials and design techniques to provide optimum sealing performance for each application. The outcome is a superior sealing solution, which retains a compact seal envelope.

Standard elastomeric rotary shaft seals have a limited application range with respect to temperature, surface speed, media compatibility, pressure or a combination of these due to the inherent limitations of the various elastomer grades. Furthermore they only have a limited suitability for applications with inadequate lubrication.

Turcon® Varilip® PDR rotary shaft seals are characterized in particular by the low friction and their stick-slip-free running, reducing the temperature generation and permitting higher peripheral speeds.

Turcon® has the characteristic of inherent memory, whereby a distorted Turcon® component will attempt to recover to the profile it had during the sintering cycle of its manufacturing process. This feature is used to provide the necessary radial loading of the sealing lip onto the shaft, negating the requirement for the energizing spring present in elastomeric seal designs.

■ General Description

Turcon® Varilip® PDR seals are constructed from only two parts - a precision manufactured metal body and a mechanically retained Turcon® sealing element. Unlike seals with pressed metal cases, a gasket is not required to provide sealing between the lip and casing. This is provided by the mechanical retention of the lip, improving both the chemical resistance and temperature range of the sealing system.

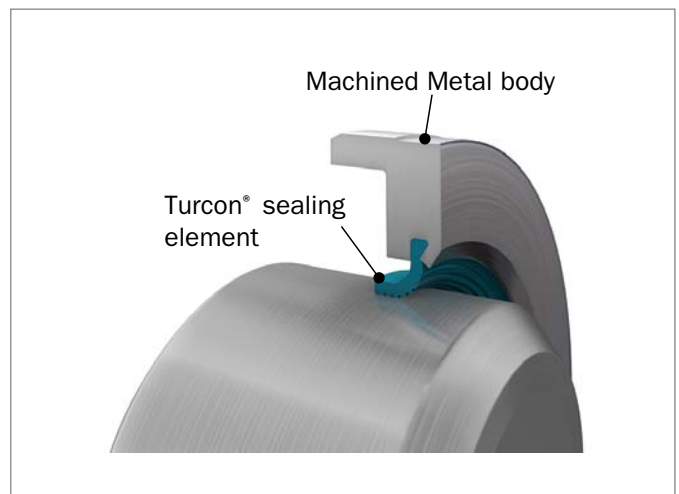

Figure 95: Turcon® Varilip® PDR seal





Where required, the Turcon® Varilip® PDR seal is available with a hydrodynamic feature on the Turcon® sealing lip. This provides a positive displacement of the fluid as a result of the shaft rotation to give improved sealing in applications where the shaft only rotates in a single direction. The feature also increases the flexibility of the lip, which allows a wider contact band between the Turcon® lip and the shaft and helps to reduce shaft load and associated wear temperature.

The mechanical retention of the Turcon® provides a robust product which also eliminates the sometimes environmentally hazardous process of bonding the Turcon® to a metal or elastomer substrate.

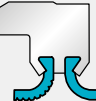

■ Product Range

Table 62: Seal configurations

Seal	Description
<p>Type A/Type 1</p> 	<p>Type A is a single lip seal suitable for use in standard industrial applications up to a pressure of 0.5 MPa (73 psi) where an elastomer radial shaft seal would be unable to withstand the temperature, friction, media or poor lubrication. Allows sealing at surface speeds up to 90 m/s (17,721 ft/min) with sufficient cooling and lubrication of the sealing lip.</p>
<p>Type B/Type 3</p> 	<p>Type B is the preferred choice for applications in which a high seal integrity is demanded or where contaminated media are to be sealed. This type offers a back-up sealing lip to provide secondary sealing. Pressure limit is 0.5 MPa (73 psi).</p>
<p>Type C/Type 4</p> 	<p>Type C can be used for applications involving higher pressures for which a simple elastomer radial shaft seal can no longer be considered. Due to reinforcement of the sealing lip, pressures up to 1 MPa (145 psi) are possible, e.g. as pump, shaft or rotor seals.</p>
<p>Type D/Type 5</p> 	<p>Type D can be subjected to pressure from both sides. Pressure differential of up to 0.5 MPa (73 psi) is permissible. The separation of two different media using a single seal is possible. The second lip can also take on the function of a wiper or dust lip.</p>
<p>Type G/Type 6</p> 	<p>Type G is similar to Type D but has a non-contacting environmental sealing element rather than a full laydown lip. This provides effective sealing against the ingress of dust and dirt into the system while also ensuring torque and resulting power consumption are kept to a minimum.</p>



TURCON® VARILIP® PDR - SPECIAL DESIGNS

Apart from the standard range, Turcon® Varilip® PDR seals are available as special designs to satisfy the demands of specific applications and can accommodate non-standard housing and shaft sizes. Figure 96 to Figure 99 show some of the special designs available.

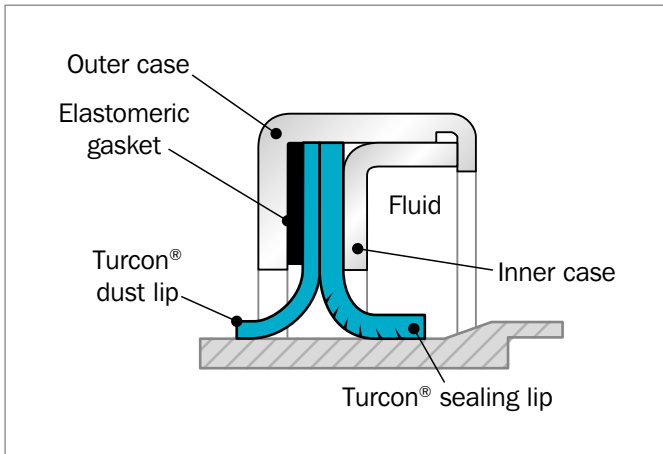

Figure 96: Clamped design

Suited to high volume applications with excessive housing tolerance.

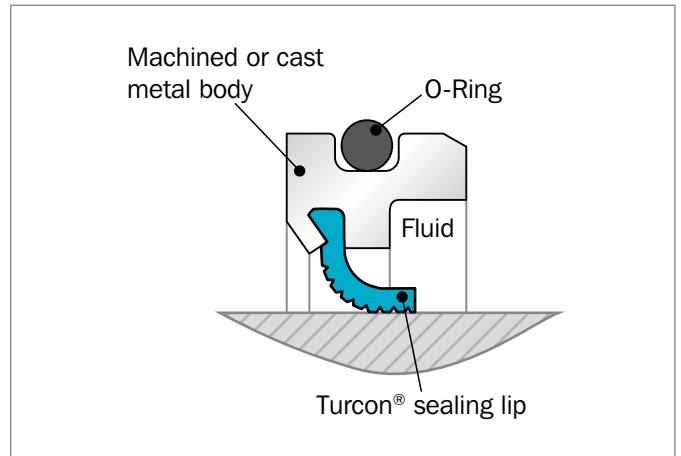

Figure 97: O-Ring design

For low interference fits in the housing.

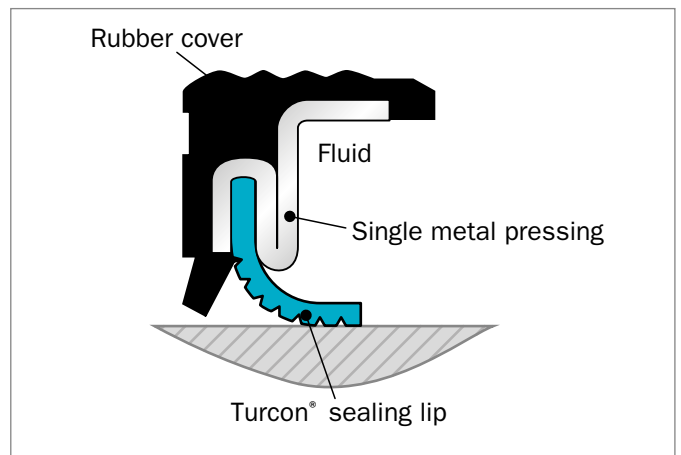

Figure 98: Single shell design

Rubber cover for poor housing surface finish at low press-in loads.

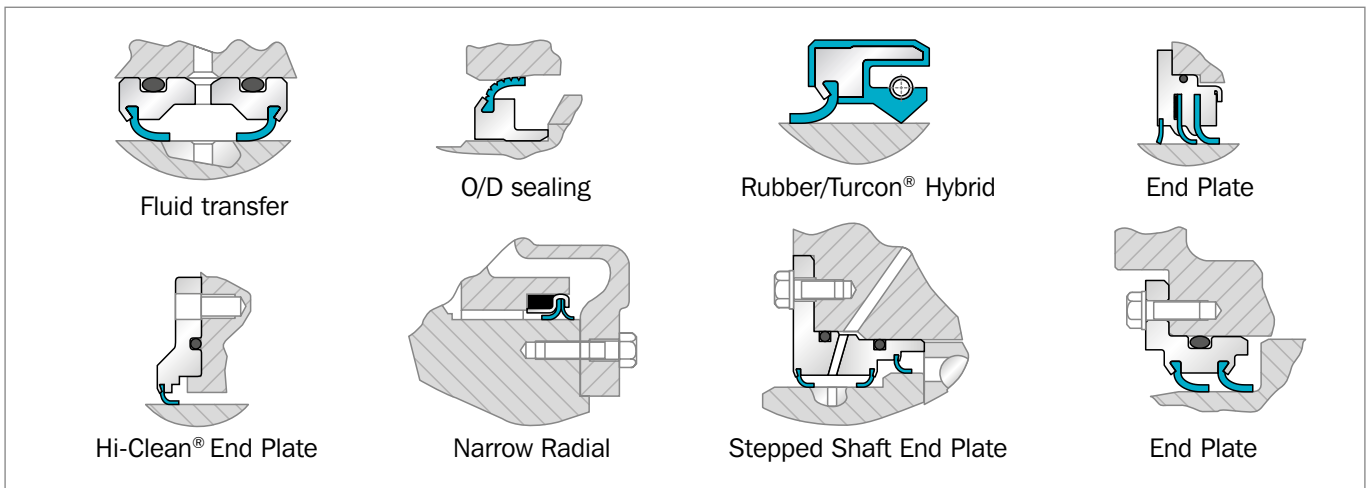

Figure 99: Variants



Materials

SEALING LIP

An important factor for the proper function of rotary shaft seals is the material used for the sealing lip. For this reason, Trelleborg Sealing Solutions has developed a range of specially modified materials on the basis of the proven Turcon® materials. Particular importance is attached to the optimization of friction and wear properties, while providing excellent sealing performance, even at high peripheral speeds.

Table 63 gives the materials available for use in Turcon® Varilip® PDR seals. Additional compounds have been developed for specific applications and these are available on request.

Table 63: Sealing Element Materials

Material, Applications, Properties	Code	Operating Temperature		Mating Surface Hardness	MPa/psi max.
		°C	°F		
Turcon® T25 Standard material with exceptional wear and friction characteristics For lubricated running, e.g. oil, grease, glass fiber, lubricant Color: Gray	T25	-60 to +200	-76 to +392	Min. 55 HRc At low pressure and up to 4 m/s (788 fpm), min.45 HRc	2 MPa 290 psi
Turcon® T40 For all lubricating and non-lubricating fluids, especially water Used for media hard shafts in applications where there is risk of shaft wear Carbon fiber Color: Gray	T40	-60 to +200	-76 to +392	Min. 30 HRc	2 MPa 290 psi
Turcon® T78 Particularly good running behavior permits use with dry running or poor lubrication and in conjunction with soft shaft surfaces e.g. stainless steel shafts in food, pharmaceutical and chemical industries. Aromatic polymer Color: Tan to Dark Brown	T78	-60 to +200	-76 to +392	Min. 55 HRc	0.2 MPa 29 psi
Turcon® M83 Specially designed for dry-running applications. Particularly good results in applications for the semiconductor industry. Can also be used lubricated Glass fiber, pigment. Color: Yellow	M83	-60 to +200	-76 to +392	Min. 55 HRc	2 MPa 290 psi

Other Turcon® materials are available by using the relevant material code when ordering. FDA compliant materials available on request.



METAL BODY

Turcon® Varilip® PDR seals are available with a preferred material choice of Stainless Steel 304L. Other materials such as Stainless Steel 316L and Zinc-plated Mild Steel are available within the standard range. Table 64 shows the codes for these materials. Other specialized materials are available on request. It should be noted that any material other than Stainless Steel 304L will result in extended lead-time due to stocking and / or additional process issues.

Table 64: Metal Body Materials

Code	Material
1	Stainless Steel 304
2	Stainless Steel 316
3	Unavailable
4	Mild Steel (Zinc-plated)
5	Aluminum

 Highlighted materials are preferred.



Operating Conditions

SPEED

The graph in Figure 100 shows the superior surface speed capability of Turcon® Varilip® PDR compared to elastomeric shaft seals.

The operating speed directly impacts the temperature generated by the seal and is an important factor when considering the requirements for the sealing system.

The actual limiting speed will depend on the temperature, pressure, media, lubrication properties, heat dissipation and the shaft condition.

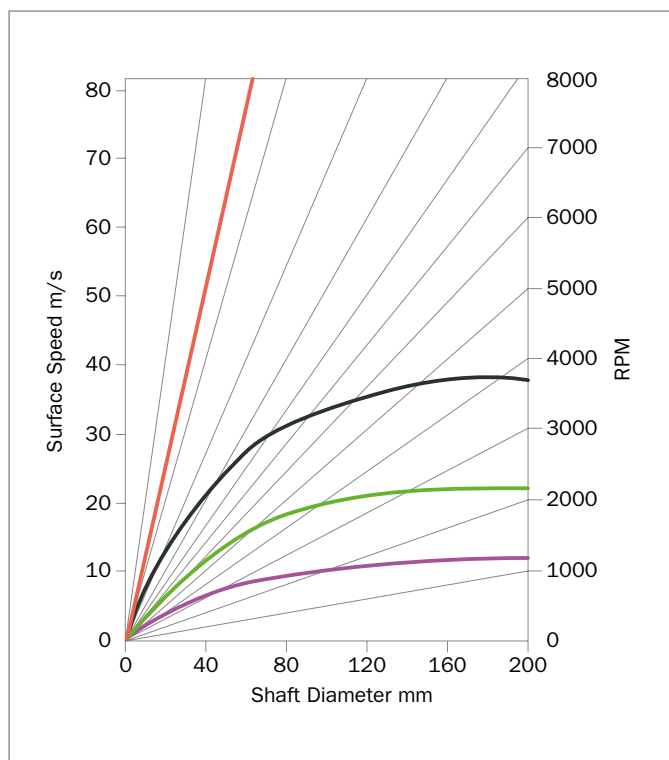







Figure 100: Surface speed as a function of shaft diameter and RPM

Table 65: Surface Speed

General Recommended maximum Surface Speed			
Turcon® Varilip® PDR		100 m/s	19,680 ft/min
Fluoroelastomer		38 m/s	7,500 ft/min
Silicone		38 m/s	7,500 ft/min
Polyacrylic		22 m/s	4,320 ft/min
Nitrile		12 m/s	2,340 ft/min

Speed capability depends on application conditions.

TEMPERATURE

All Turcon® Varilip® PDR seals are capable of outstanding high and low temperature performance compared to elastomeric materials.

Unlike other PTFE lip seals, the Turcon® Varilip® PDR seal is not limited in its temperature performance by the presence of an elastomer gasket. This gives it excellent temperature range capability.

The temperatures in Figure 101 are general working limits of the seal material, and in all cases the effective limit for a rotary shaft seal application would be much lower.

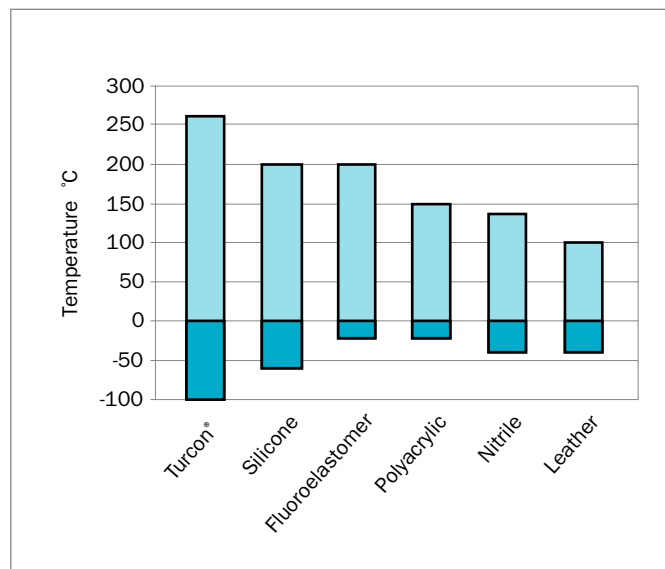

Figure 101: Maximum and minimum temperatures for different materials

Table 66: Temperature

General Recommended minimum / maximum Temperature		
Filled PTFE	-100 to +260 °C	-148 to +500 °F
Fluoroelastomer	-20 to +200 °C	-4 to +392 °F
Silicone	-60 to +200 °C	-76 to +392 °F
Polyacrylic	-20 to +150 °C	-4 to +300 °F
Nitrile	-40 to +135 °C	-40 to +275 °F
Leather	-40 to +100 °C	-40 to +212 °F



PRESSURE

Turcon® Varilip® PDR Types A, B, D and G are suitable for pressures up to 0.5 MPa (73 psi).

Pressure heavily influences the contact force between the Turcon® lip and the shaft and consequently the heat generation. This must be taken into consideration when selecting the appropriate seal type.

Turcon® Varilip® PDR seals can remain leak tight when exposed to pressurization during static shaft conditions.

FLUID RESISTANCE

Turcon® consists of fully substituted carbon-carbon chains and the resulting carbon-fluorine bonds are among the strongest known in organic chemistry. The outstanding physical and chemical properties of Turcon® can be attributed to these strong bonds.

Turcon® Varilip® PDR seals are resistant to mineral acids, bases, common organic fluids and solvents. They are also unaffected by oxidation, ultraviolet radiation or ozone, making them ideally suited for use in the chemical industry and applications requiring exposure to the atmosphere.

A particular benefit of Turcon® Varilip® PDR seals is a resistance to oil additives and biofuels, which have an adverse effect on many elastomers. Using Turcon® shaft seals allows the increased use of additives and a longer oil service life.

Many Turcon® materials have been successfully tested in 20% Fluorine gas at temperatures in excess of +250 °C (+482 °F).

LUBRICATION STARVATION

Turcon® Varilip® PDR shaft seals have the capability to run without lubrication for longer periods of time compared with elastomer shaft seals without adversely affecting their ultimate life. This not only allows them to be used in applications where the lubrication may be intermittent as a result of start up or other operating factors, but also allows their use as effective dirt, dust and powder seals.

NOTE

Higher speeds and pressure capabilities can be achieved through the use of custom designs. Please consult your local Trelleborg Sealing Solutions marketing company.



POWER CONSUMPTION

One of the key features of Turcon® Varilip® PDR is its low friction, resulting in very low power consumption.

Figure 102 shows the running torque for a 40 mm (1.73 in) shaft diameter Turcon® Varilip® PDR seal.

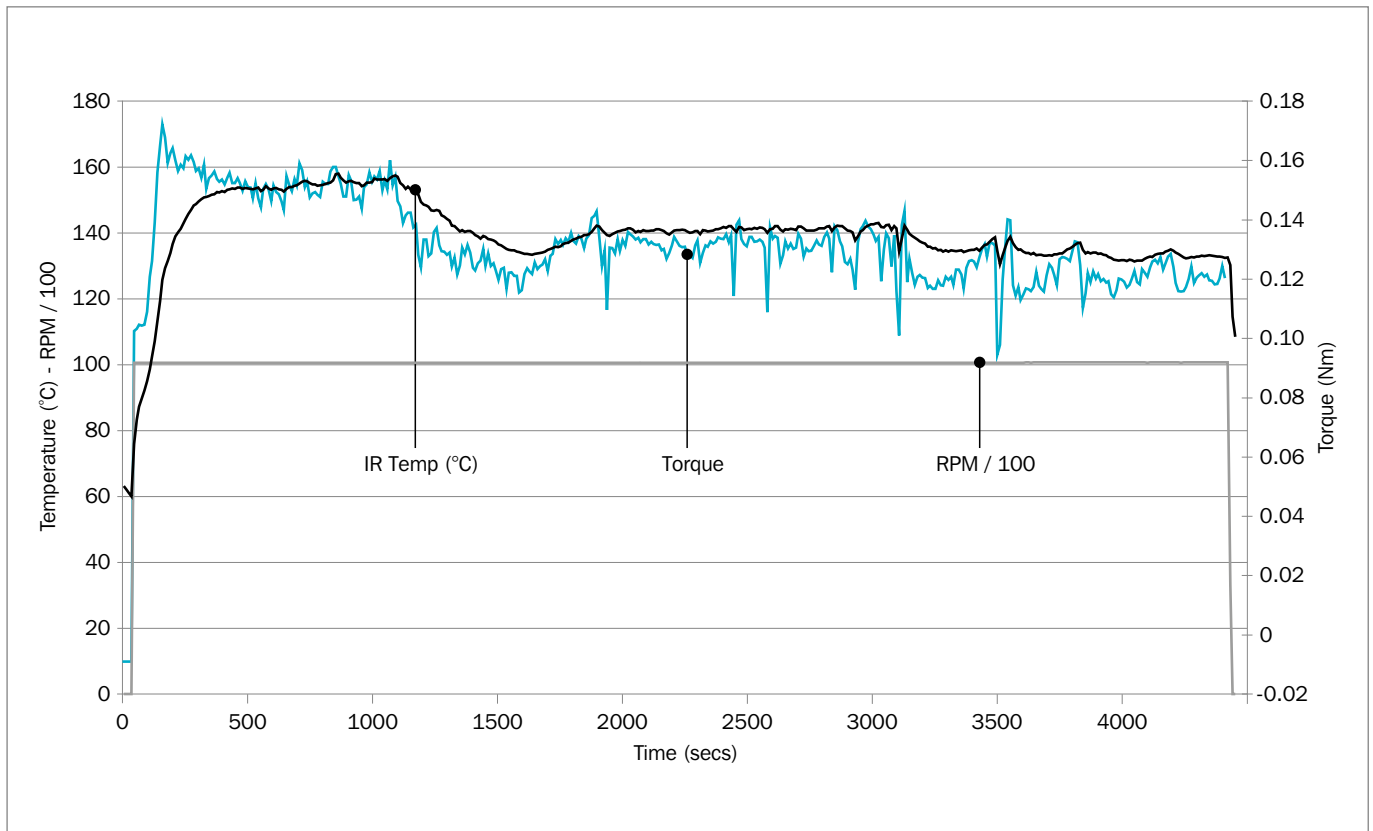

Figure 102: Running torque for Turcon® Varilip® PDR seal

Reduced torque can be achieved through custom designs but may reduce leak tightness.

NOTE

Results may vary according to application and conditions.



ENDURANCE



Turcon® Varilip® PDR rotary shaft seals can provide extended service life compared with elastomer shaft seals. As with any seal, however, the life of a Turcon® Varilip® PDR seal depends on the specific operating parameters.

PTFE is an inherently stable material and does not suffer from aging or degradation as with elastomers.

ECCENTRICITY

The graph in Figure 103 shows the maximum recommended operating envelope for silicone, nitrile, polyacrylic and fluoroelastomer seals. Turcon® Varilip® PDR seals have a specific lip design to minimize the risk of leakage and reduce wear rates. Therefore the levels of eccentricity should be kept within the limits shown. In order to achieve a uniform radial load of the sealing lip on the shaft, the best possible coaxiality, or static offset should be maintained between the housing bore and the shaft, as shown in Figure 104.

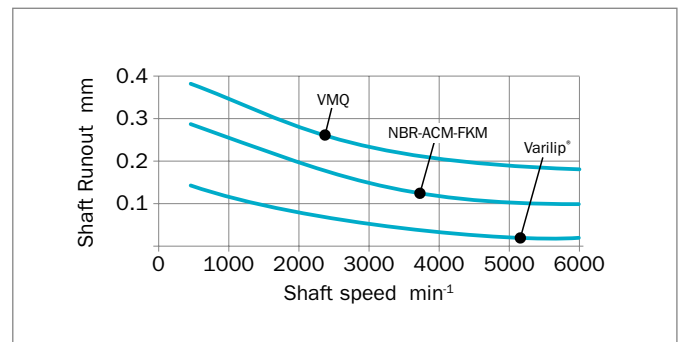

Figure 103: Dynamic eccentricity capability

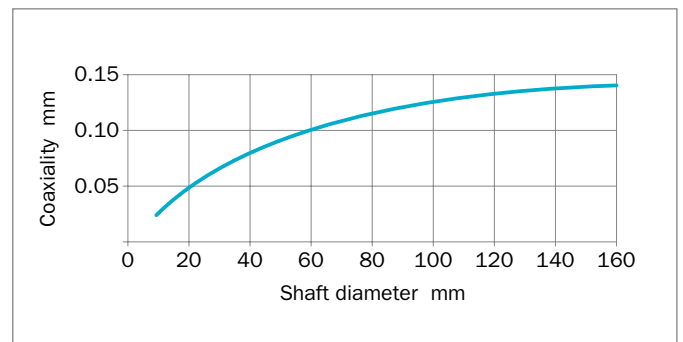

Figure 104: Coaxial tolerance capability



LEAKAGE EXPECTATION

The hydrodynamic feature available on Turcon® Varilip® PDR helps to ensure improved leak tightness compared to other PTFE lip seals. Note that seals with hydrodynamic features must be used only in one direction.

The following graphs show the results obtained from 200 hour tests. These tests compared the leakage performance of the Turcon® Varilip® PDR seal against two competitors' PTFE lip seals. The results obtained are shown below.

Figure 105 details the leakage rate measured at regular intervals throughout the test. Figure 106 plots a cumulative graph to indicate total leakage. It can be noted that the Turcon® Varilip® PDR outperforms the two competitor seals with regard to leakage performance.

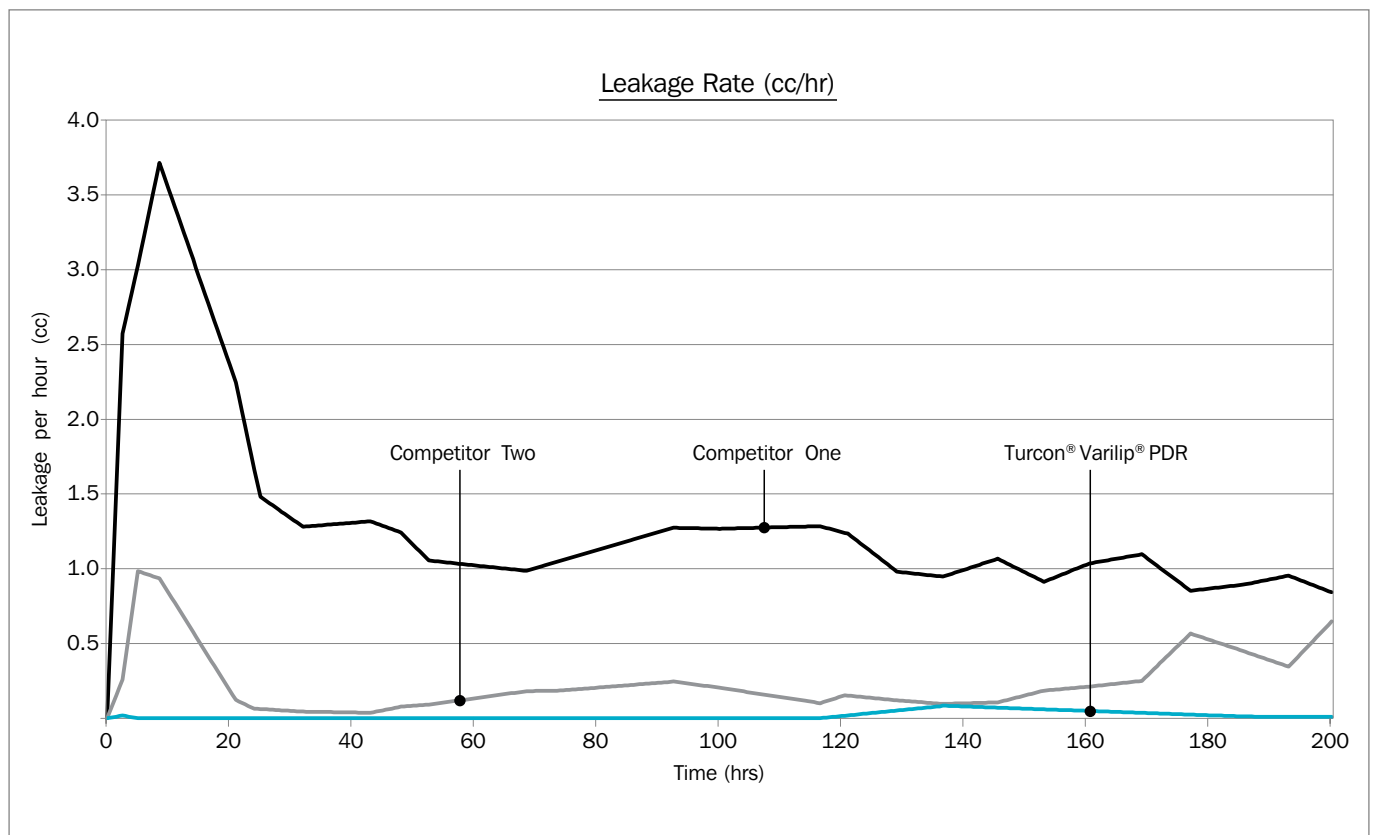

Figure 105: Leakage rate per hour monitored over 200 hour tests (average results)

Turcon® Varilip® PDR seals sometimes need a short bedding-in period before optimal sealing is provided depending on shaft topography. Once the run band is established, wear rates slow to provide good seal life.

NOTE

Results may vary according to application and conditions.

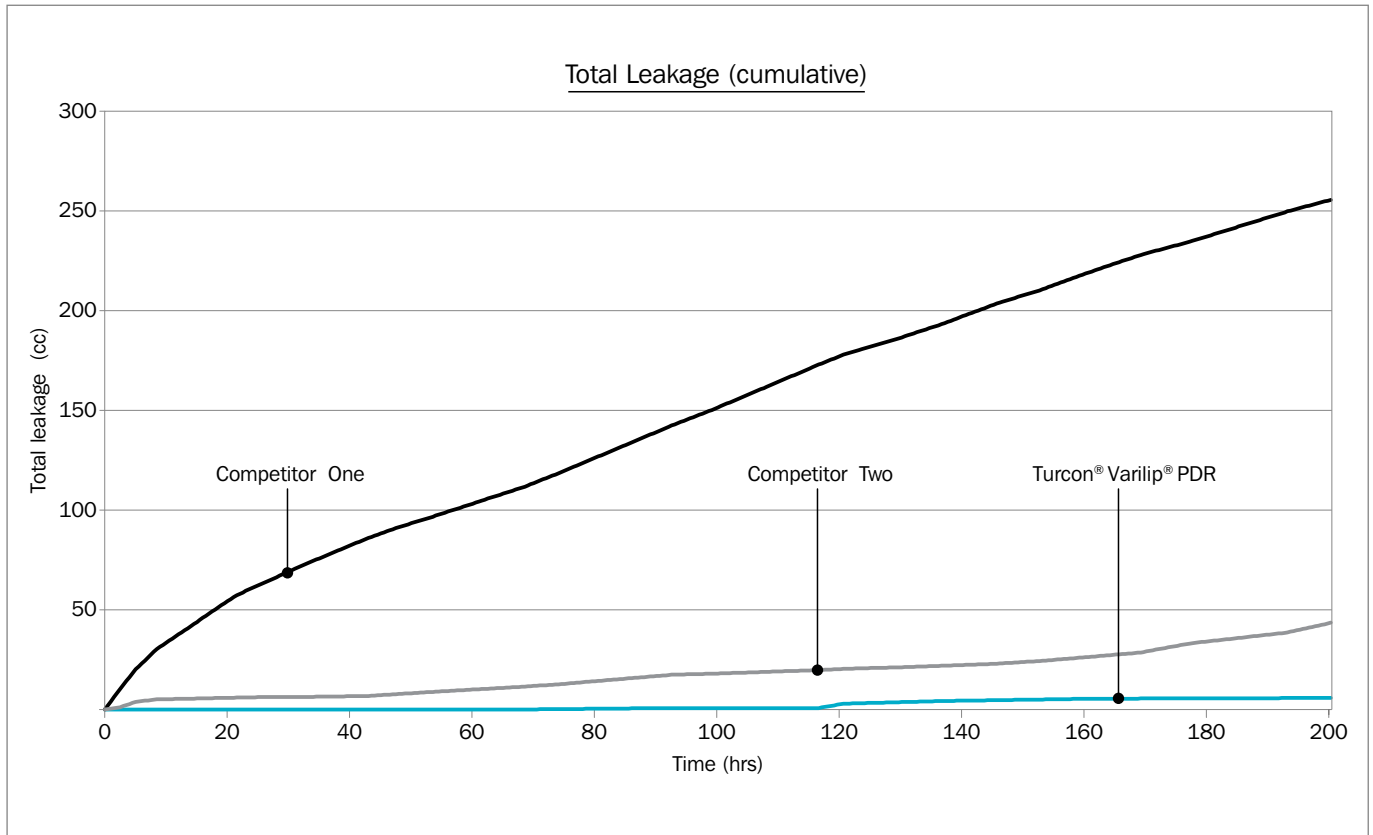

Figure 106: Total leakage (cumulative) monitored over 200 hour tests (average results)

NOTE

Results may vary according to application and conditions.



HEAT GENERATION CONSIDERATIONS

All Turcon® Varilip® PDR seals are designed to contact the shaft surface during operation. The contact force between the sealing lip and the shaft will depend on the seal design used and the application details, but in all cases a temperature increase due to the presence of the seal can be expected. Where this increase is likely to be significant, consideration should be given to methods of reducing the level of generated heat. This can be achieved through increases in localized cooling, improved lubrication and efficient heat transfer and dissipation mechanisms.

SHAFT WEAR

Turcon® Varilip® PDR seals are designed to contact the shaft surface during operation and a seal contact band will be evident in the majority of applications. With correct seal specification and operating conditions, shaft wear should be limited to a light polishing, but factors such as over pressure, contamination, eccentricity or insufficient shaft hardness can result in more significant wear.

As part of the system design, consideration should be given to the level of shaft wear permissible within a set operating period, and therefore the benefits of measures intended to reduce the rate of wear, such as shaft coatings, can be analyzed in relation to their additional cost.

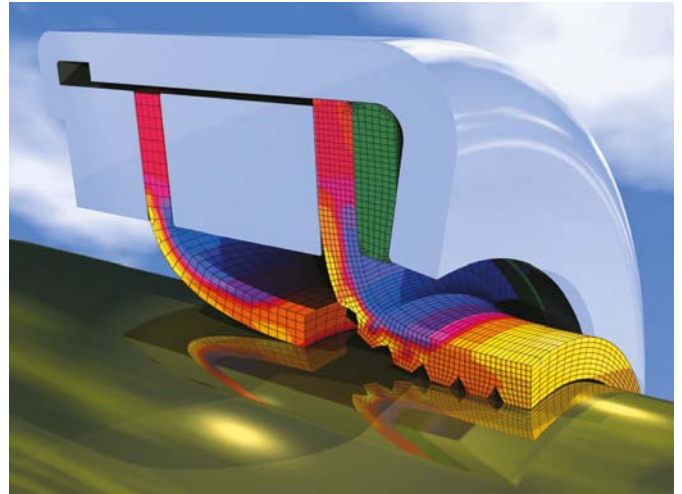



■ Design Guidelines

HOUSING

Turcon® Varilip® PDR seals are designed to meet global standards, including ISO 6194/1 and ISO 16589 (see Table 71 and Table 72).

Turcon® Varilip® PDR seals require an interference fit with the housing bore to provide both adequate sealing of this interface and to ensure that the seal remains in place when subjected to pressure, axial movement and induced torsion produced by the relative rotary motion of shaft to housing bore. The bore should be machined with an H8 diametric tolerance as reproduced in Table 67 below. System design should also ensure that Turcon® Varilip® PDR seals are not pushed into bores that may have been previously scored by the assembly of another component, (such as a bearing), selecting a larger seal outer diameter if necessary.

For Turcon® Varilip® PDR seals the bore should have a surface finish of $0.8 \mu\text{m}$ ($32 \mu\text{in}$) Ra maximum. In cases where the housing bore is split resulting in an axial joint crossing the seal outer diameter, and in cases where meeting these surface finish requirements is not possible, it is recommended that a proprietary sealant or adhesive is used.

Alternatively a custom solution can be prepared employing a rubber covering or O-Ring for OD sealing.

Table 67: Housing Installation Data Table

Bore Diameter				Tolerance	
Over		To		H8 [mm]	x10 ⁻³ [in]
mm	inch	mm	inch		
10	0.394	18	0.787	+0.027 -0	0.0011
18	0.787	30	1.181	+0.033 -0	0.0013
30	1.181	50	1.969	+0.039 -0	0.0015
50	1.969	80	3.150	+0.046 -0	0.0018
80	3.150	120	4.724	+0.054 -0	0.0021
120	4.724	180	7.087	+0.063 -0	0.0025
180	7.087	250	9.843	+0.072 -0	0.0028
250	9.843	315	12.402	+0.081 -0	0.0032
315	12.402	400	15.748	+0.089 -0	0.0035

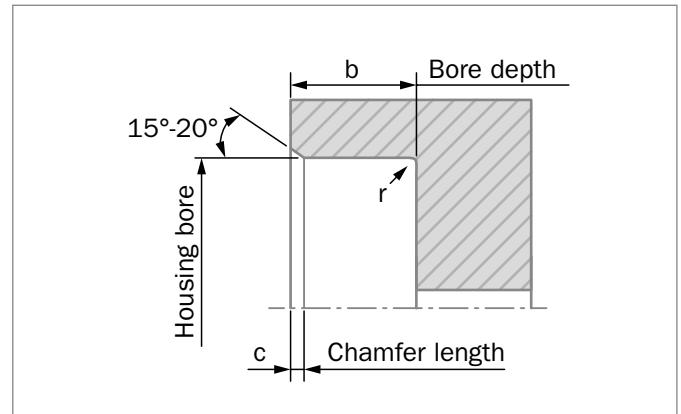

Figure 107: Housing design schematic

Table 68: Housing Design Data

Seal Width	Up to 10 [mm] / 0.394 inch	Over 10 [mm] / 0.394 inch
Min. bore depth (b)	b + 0.5 (0.0197 in)	b + 1.0 (0.0394 in)
Chamfer length (c)	0.70 to 1.00 (0.028 in to 0.04 in)	1.20 to 1.50 (0.047 in to 0.06 in)
Max. corner rad. (r)	0.40 (0.0157 in)	0.40 (0.0157 in)

SHAFT

This should be machined to an h11 tolerance or better, reproduced in Table 68. The surface finish should be prepared by plunge grinding to avoid any machining leads that may act with the shaft rotation to facilitate leakage.

The recommended surface finish for Turcon® Varilip® PDR seals is 0.2 to $0.4 \mu\text{m}$ ($8 - 16 \mu\text{inch}$) Ra.



Table 69: Shaft Installation Data

Shaft Diameter				Tolerance	
Over		To		h11	h11
mm	inch	mm	inch	[mm]	[inch]
6	0.236	10	0.394	+0 -.900	+0 -0.0035
10	0.394	18	0.787	+0 -.110	+0 -0.0043
18	0.787	30	1.181	+0 -.130	+0 -0.0051
30	1.181	50	1.969	+0 -.160	+0 -0.0063
50	1.969	80	3.150	+0 -.190	+0 -0.0075
80	3.150	120	4.724	+0 -.220	+0 -0.0087
120	4.724	180	7.087	+0 -.250	+0 -0.0098
180	7.087	250	9.843	+0 -.290	+0 -0.0114
250	9.843	315	12.402	+0 -.320	+0 -0.0126
315	12.402	400	15.748	+0 -.360	+0 -0.0142

A shaft hardness in excess of 55 HRC is generally recommended for Turcon® Varilip® PDR, although lower values are permissible depending on the pressure, speed and sealing lip material used (refer to materials section).

Titanium shafts should be avoided unless nitrided. Shafts with good chrome, nickel or zinc plating, properly finished, are acceptable. Certain ceramic coatings can also be used, although some grades have been proven to result in an aggressive wear of the sealing lip due to their open structure. In certain applications it may not be possible to provide a shaft with the necessary hardness, surface finish and corrosion resistance. Fitting a wear sleeve onto the shaft can solve this problem by providing the local hardness and surface requirement without affecting the main shaft. If wear should occur, only the sleeve need then be replaced. The surface finish of the sleeve should be as outlined above and consideration should be given to adequate heat dissipation and effective sealing of the interface between the wear sleeve and the shaft.





■ Installation Requirements

When installing Turcon® Varilip® PDR seals, careful handling is important in order to avoid damaging the sealing lip. If the seal is installed from the back, radii or lead-in chamfers must be machined on the end of the shaft. This must also be free from burrs, sharp corners or rough machining marks, as shown in Figure 108.

When installing the seal with the lip against the shaft end, a lead-in chamfer is required whose smallest diameter is smaller than the unstressed diameter of the sealing lip as shown Figure 109. Table 70 shows guide values for this.

It is recommended that as shallow an angle as practical be adopted within the range given.

Table 70: Shaft lead-in chamfer

d1 [mm]	d1 [inch]	d1 - d2 [mm]	d1 - d2 [inch]
< 10	0.4	1.5	0.06
10 - 20	0.4 - 0.8	2.0	0.08
20 - 30	0.8 - 1.2	2.5	0.10
30 - 40	1.2 - 1.6	3.0	0.12
40 - 50	1.6 - 2.0	3.5	0.14
50 - 70	2.0 - 2.8	4.0	0.16
70 - 95	2.8 - 3.7	4.5	0.18
95 - 130	3.7 - 5.1	5.5	0.22
130 - 240	5.1 - 9.4	7.0	0.28
240 - 300	9.4 - 11.8	11.0	0.43

Preferable is the use of an installation cone, as shown in Figure 110, where the seal can be fitted onto the cone before being located on the shaft to ensure correct orientation of the sealing lip.

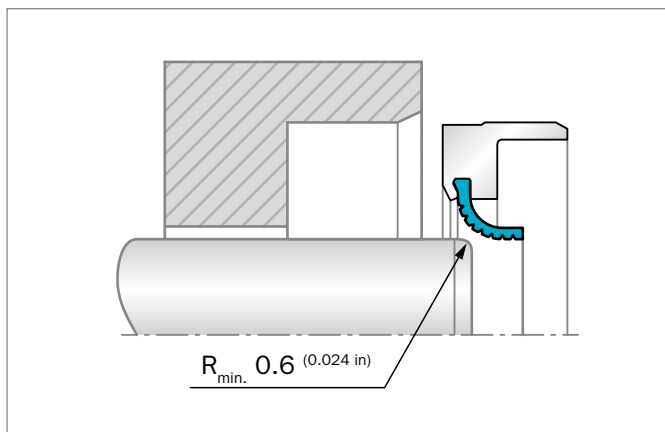

Figure 108: Installation of the sealing lip with the back to the shaft for pressurized application

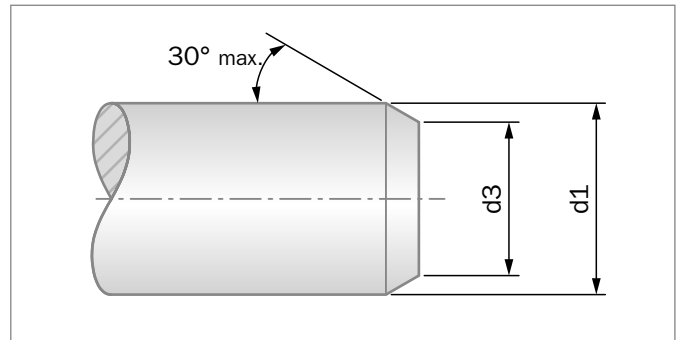

Figure 109: Shaft lead-in chamfer

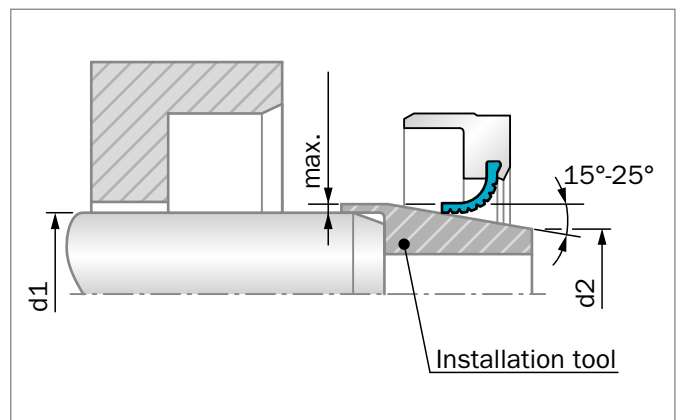

Figure 110: Fitting the sealing lip using an installation tool

Fitting should be performed in a swift movement to limit the time that the lip is formed above shaft size, therefore reducing lip recovery.

■ Packaging

Single and low quantities of Turcon® Varilip® PDR seals will be supplied in a blister pack with an individual transport mandrel. This mandrel will pre-form the element to above its free diameter, but below the intended shaft diameter. This assists in ease of installation, while also ensuring the element is not over-formed or damaged in transit.

Larger quantities of Turcon® Varilip® PDR seals will be supplied in a tube-and-end cap configuration.

■ Storage

Turcon® Varilip® PDR seals do not require any special storage conditions, unlike elastomer seals which must be kept away from sunlight and elevated temperatures to avoid rubber degradations.

Turcon® Varilip® PDR seals are not subject to shelf life.



■ Fitting Instructions

Investigation of premature failures has shown that a significant proportion are a result of inappropriate installation techniques. However, by observing the following guidelines, such failures can be avoided:

- Assembly sleeves and fitting tools should be regularly checked for signs of damage.
- When supplied on mandrels the seals should not be removed from the mandrel until immediately prior to fitting. Seals supplied on cardboard mandrels should be removed in the direction such that the spiral paper overlay of the mandrel is not lifted.
- Turcon® Varilip® PDR seals should be assembled on the shaft in a non-lubricated (dry) condition to avoid contamination of the hydrodynamic feature (if present).
- Care should be taken not to damage the outer diameter surface of the seal.
- Seals should be pressed squarely into the housing with the pressing-in force applied as close as possible to the outside diameter of the seal.
- If the seal contains a hydrodynamic feature on the sealing lip, ensure that it is correctly oriented in relation to the shaft's direction of rotation.
- Normal practice is to install the seal with the lip facing the media to be sealed (the seal is reversed only when it becomes more important to exclude a media than to retain it).
- Proprietary sealants or adhesives may be used for improved sealing of the outer diameter in critical applications or for seal retention purposes.

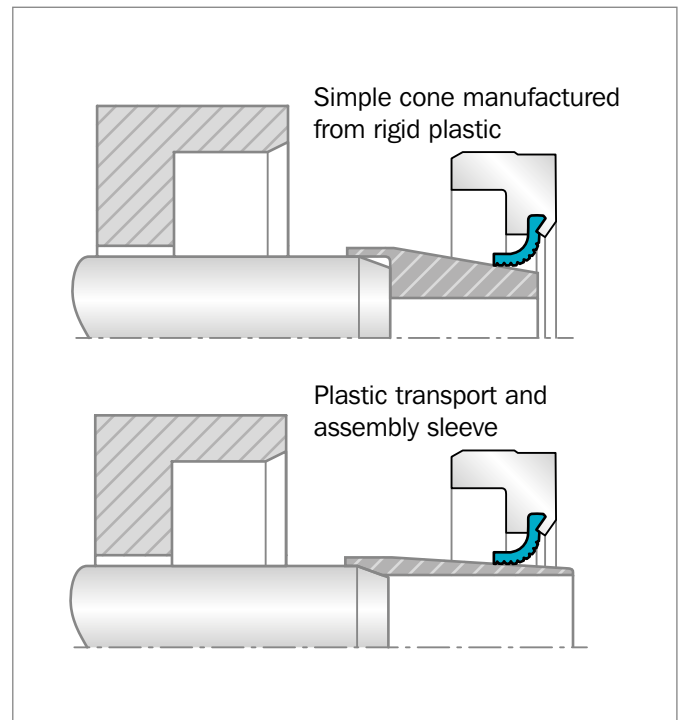

Figure 111: Assembly tooling types for installation on shafts

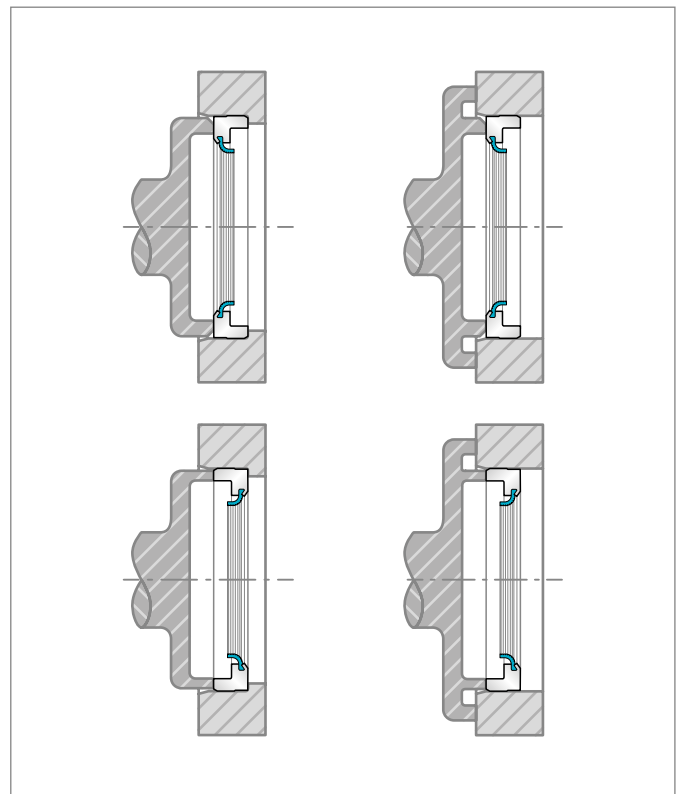

Figure 112: Assembly tooling types for press fit into a housing



■ Installation Recommendations

The following diagrams show installation recommendations in respect to seal retention under pressure conditions.

POST INSTALLATION RECOMMENDATIONS

If painting, be sure to mask the seal. Avoid getting paint on the lip or the shaft where the lip rides. Also, mask any vents or drain holes so they will not become clogged. Be sure to remove masks before operating unit.

If paint is to be baked, or the mechanism is otherwise subjected to heat, seals should not be heated to temperatures higher than their materials can tolerate.

In cleaning or testing, do not subject seals to any fluids or pressures other than those for which the seals have been specified.

Extraction features such as tapped holes, internal threads or simple grooves can be included in custom PDR designs.

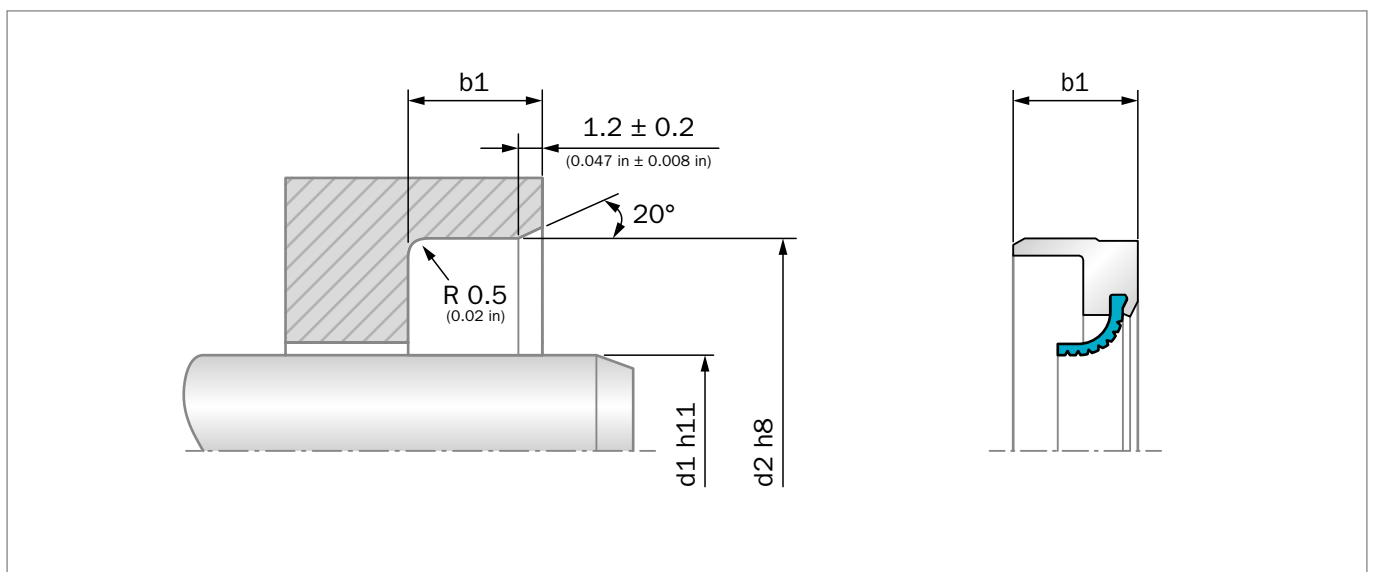

Figure 113: Installation drawing for pressure up to 0.5 MPa (73 psi)

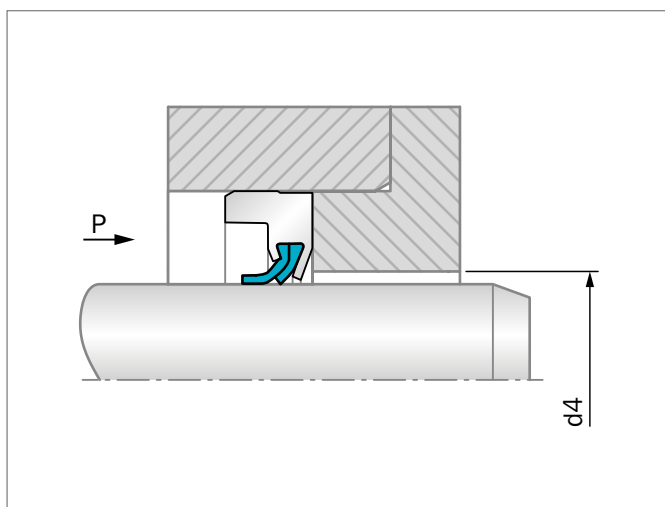

Figure 114: Installation for pressure from 0.5 MPa (73 psi) up to 1 MPa (145 psi)

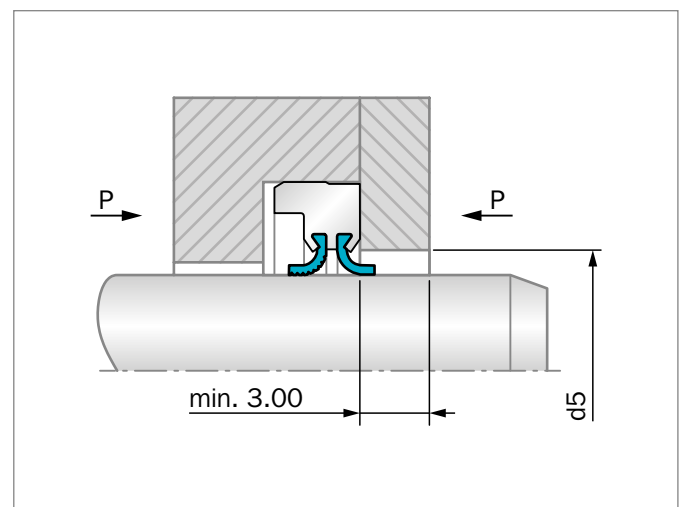

Figure 115: Installation type for fluid separation at pressures up to 0.5 MPa (145 psi)



■ Size Ranges

Table 71: Turcon® Varilip® PDR Metric Size Range

Sizes				TSS Part No.	Sizes		
d1 [mm]	d2 [mm]	b [mm] exc. TJB	b [mm] TJB		b1 min. [mm]	d4 max. [mm]	d5 min. [mm]
6	16	7	10	TJ_1_0060	7.3 / 10.3	10	9.6
6	22	7	10	TJ_2_0060	7.3 / 10.3	10	9.6
7	22	7	10	TJ_1_0070	7.3 / 10.3	11	10.6
8	22	7	10	TJ_1_0080	7.3 / 10.3	12	11.6
8	24	7	10	TJ_2_0080	7.3 / 10.3	12	11.6
9	22	7	10	TJ_1_0090	7.3 / 10.3	13	12.6
9	24	7	10	TJ_2_0090	7.3 / 10.3	13	12.6
9	26	7	10	TJ_3_0090	7.3 / 10.3	13	12.6
10	22	7	10	TJ_1_0100	7.3 / 10.3	14	13.6
10	24	7	10	TJ_2_0100	7.3 / 10.3	14	13.6
10	25	7	10	TJ_3_0100	7.3 / 10.3	14	13.6
10	26	7	10	TJ_4_0100	7.3 / 10.3	14	13.6
11	22	7	10	TJ_1_0110	7.3 / 10.3	15	14.6
11	26	7	10	TJ_2_0110	7.3 / 10.3	15	14.6
12	22	7	10	TJ_1_0120	7.3 / 10.3	16	15.6
12	24	7	10	TJ_2_0120	7.3 / 10.3.3	16	15.6
12	25	7	10	TJ_3_0120	7.3 / 10.3	16	15.6
12	28	7	10	TJ_4_0120	7.3 / 10.3	16	15.6
12	30	7	10	TJ_5_0120	7.3 / 10.3	16	15.6
14	24	7	10	TJ_1_0140	7.3 / 10.3	18	17.6
14	28	7	10	TJ_2_0140	7.3 / 10.3	18	17.6
14	30	7	10	TJ_3_0140	7.3 / 10.3	18	17.6
14	35	7	10	TJ_4_0140	7.3 / 10.3	18	17.6
15	26	7	10	TJ_1_0150	7.3 / 10.3	19	18.6
15	30	7	10	TJ_2_0150	7.3 / 10.3	19	18.6
15	32	7	10	TJ_3_0150	7.3 / 10.3	19	18.6
15	35	7	10	TJ_4_0150	7.3 / 10.3	19	18.6
16	28	7	10	TJ_1_0160	7.3 / 10.3	20	19.6
16	30	7	10	TJ_2_0160	7.3 / 10.3	20	19.6
16	32	7	10	TJ_3_0160	7.3 / 10.3	20	19.6
16	35	7	10	TJ_4_0160	7.3 / 10.3	20	19.6
17	28	7	10	TJ_1_0170	7.3 / 10.3	21	20.6
17	30	7	10	TJ_2_0170	7.3 / 10.3	21	20.6
17	32	7	10	TJ_3_0170	7.3 / 10.3	21	20.6
17	35	7	10	TJ_4_0170	7.3 / 10.3	21	20.6
17	40	7	10	TJ_5_0170	7.3 / 10.3	21	20.6
18	30	7	10	TJ_1_0180	7.3 / 10.3	22	21.6

Sealing lips may, in some cases, protrude beyond the edge of the seal body.
 Sizes printed in **bold** are preferred. Sizes not stated on these tables are available on request (note this will include a tooling charge).



Sizes				TSS Part No.	Sizes		
d1 [mm]	d2 [mm]	b [mm] exc. TJB	b [mm] TJB		b1 min. [mm]	d4 max. [mm]	d5 min. [mm]
18	32	7	10	TJ_2_0180	7.3 / 10.3	22	21.6
18	35	7	10	TJ_3_0180	7.3 / 10.3	22	21.6
18	40	7	10	TJ_4_0180	7.3 / 10.3	22	21.6
20	30	7	10	TJ_1_0200	7.3 / 10.3	24	23.6
20	32	7	10	TJ_2_0200	7.3 / 10.3	24	23.6
20	35	7	10	TJ_3_0200	7.3 / 10.3	24	23.6
20	40	7	10	TJ_4_0200	7.3 / 10.3	24	23.6
20	47	7	10	TJ_5_0200	7.3 / 10.3	24	23.6
22	32	7	10	TJ_1_0220	7.3 / 10.3	26	25.6
22	35	7	10	TJ_2_0220	7.3 / 10.3	26	25.6
22	40	7	10	TJ_3_0220	7.3 / 10.3	26	25.6
22	47	7	10	TJ_4_0220	7.3 / 10.3	26	25.6
24	35	7	10	TJ_1_0240	7.3 / 10.3	28	27.6
24	37	7	10	TJ_2_0240	7.3 / 10.3	28	27.6
24	40	7	10	TJ_3_0240	7.3 / 10.3	28	27.6
24	47	7	10	TJ_4_0240	7.3 / 10.3	28	27.6
25	35	7	10	TJ_1_0250	7.3 / 10.3	29	28.6
25	40	7	10	TJ_2_0250	7.3 / 10.3	29	28.6
25	42	7	10	TJ_3_0250	7.3 / 10.3	29	28.6
25	47	7	10	TJ_4_0250	7.3 / 10.3	29	28.6
25	52	7	10	TJ_5_0250	7.3 / 10.3	29	28.6
26	37	7	10	TJ_1_0260	7.3 / 10.3	30	29.6
26	42	7	10	TJ_2_0260	7.3 / 10.3	30	29.6
26	47	7	10	TJ_3_0260	7.3 / 10.3	30	29.6
28	40	7	10	TJ_1_0280	7.3 / 10.3	32	31.6
28	47	7	10	TJ_2_0280	7.3 / 10.3	32	31.6
28	52	7	10	TJ_3_0280	7.3 / 10.3	32	31.6
30	40	7	10	TJ_1_0300	7.3 / 10.3	34	33.6
30	42	7	10	TJ_2_0300	7.3 / 10.3	34	33.6
30	47	7	10	TJ_3_0300	7.3 / 10.3	34	33.6
30	52	7	10	TJ_4_0300	7.3 / 10.3	34	33.6
30	62	7	10	TJ_5_0300	7.3 / 10.3	34	33.6
32	45	7	10	TJ_1_0320	7.3 / 10.3	36	35.6
32	45	8	10	TJ_2_0320	8.3 / 10.3	36	35.6
32	47	7	10	TJ_3_0320	7.3 / 10.3	36	35.6
32	47	8	10	TJ_4_0320	8.3 / 10.3	36	35.6
32	52	7	10	TJ_5_0320	7.3 / 10.3	36	35.6

Sealing lips may, in some cases, protrude beyond the edge of the seal body.

Sizes printed in **bold** are preferred. Sizes not stated on these tables are available on request (note this will include a tooling charge).



Sizes				TSS Part No.	Sizes		
d1 [mm]	d2 [mm]	b [mm] exc. TJB	b [mm] TJB		b1 min. [mm]	d4 max. [mm]	d5 min. [mm]
32	52	8	10	TJ_6_0320	8.3 / 10.3	36	35.6
35	47	7	10	TJ_1_0350	7.3 / 10.3	39	38.6
35	50	7	10	TJ_2_0350	7.3 / 10.3	39	38.6
35	50	8	10	TJ_3_0350	8.3 / 10.3	39	38.6
35	52	7	10	TJ_4_0350	7.3 / 10.3	39	38.6
35	52	8	10	TJ_5_0350	8.3 / 10.3	39	38.6
35	55	8	10	TJ_6_0350	8.3 / 10.3	39	38.6
35	62	7	10	TJ_7_0350	7.3 / 10.3	39	38.6
36	47	7	10	TJ_1_0360	7.3 / 10.3	40	39.6
36	50	7	10	TJ_2_0360	7.3 / 10.3	40	39.6
36	52	7	10	TJ_3_0360	7.3 / 10.3	40	39.6
36	62	7	10	TJ_4_0360	7.3 / 10.3	40	39.6
38	52	7	10	TJ_1_0380	7.3 / 10.3	42	41.6
38	55	7	10	TJ_2_0380	7.3 / 10.3	42	41.6
38	55	8	10	TJ_3_0380	8.3 / 10.3	42	41.6
38	58	8	10	TJ_4_0380	8.3 / 10.3	42	41.6
38	62	7	10	TJ_5_0380	7.3 / 10.3	42	41.6
38	62	8	10	TJ_6_0380	8.3 / 10.3	42	41.6
40	52	7	10	TJ_1_0400	7.3 / 10.3	44	43.6
40	55	7	10	TJ_2_0400	7.3 / 10.3	44	43.6
40	55	8	10	TJ_3_0400	8.3 / 10.3	44	43.6
40	62	7	10	TJ_4_0400	7.3 / 10.3	44	43.6
40	62	8	10	TJ_5_0400	8.3 / 10.3	44	43.6
40	72	7	10	TJ_6_0400	7.3 / 10.3	44	43.6
42	55	8	10	TJ_1_0420	8.3 / 10.3	46	45.6
42	62	8	10	TJ_2_0420	8.3 / 10.3	46	45.6
42	72	8	10	TJ_3_0420	8.3 / 10.3	49	48.6
45	60	8	10	TJ_1_0450	8.3 / 10.3	49	48.6
45	62	8	10	TJ_2_0450	8.3 / 10.3	49	48.6
45	65	8	10	TJ_3_0450	8.3 / 10.3	49	48.6
45	72	8	10	TJ_4_0450	8.3 / 10.3	49	48.6
48	62	8	10	TJ_1_0480	8.3 / 10.3	52	51.6
48	72	8	10	TJ_2_0480	8.3 / 10.3	52	51.6
50	65	8	10	TJ_1_0500	8.3 / 10.3	54	53.6
50	68	8	10	TJ_2_0500	8.3 / 10.3	54	53.6
50	72	8	10	TJ_3_0500	8.3 / 10.3	54	53.6
50	80	8	10	TJ_4_0500	8.3 / 10.3	54	53.6
52	68	8	10	TJ_1_0520	8.3 / 10.3	56	55.6
52	72	8	10	TJ_2_0520	8.3 / 10.3	59	55.6
55	70	8	10	TJ_1_0550	8.3 / 10.3	59	58.6

Sealing lips may, in some cases, protrude beyond the edge of the seal body.
 Sizes printed in **bold** are preferred. Sizes not stated on these tables are available on request (note this will include a tooling charge).



Sizes				TSS Part No.	Sizes		
d1 [mm]	d2 [mm]	b [mm] exc. TJB	b [mm] TJB		b1 min. [mm]	d4 max. [mm]	d5 min. [mm]
55	72	8	10	TJ_2_0550	8.3 / 10.3	59	58.6
55	80	8	10	TJ_3_0550	8.3 / 10.3	59	58.6
55	85	8	10	TJ_4_0550	8.3 / 10.3	59	58.6
56	70	8	10	TJ_1_0560	8.3 / 10.3	60	59.6
56	72	8	10	TJ_2_0560	8.3 / 10.3	60	59.6
56	80	8	10	TJ_3_0560	8.3 / 10.3	60	59.6
56	85	8	10	TJ_4_0560	8.3 / 10.3	60	59.6
58	72	8	10	TJ_2_0580	8.3 / 10.3	62	61.6
58	80	8	10	TJ_2_0580	8.3 / 10.3	62	61.6
60	75	8	10	TJ_1_0600	8.3 / 10.3	64	63.6
60	80	8	10	TJ_2_0600	8.3 / 10.3	64	63.6
60	85	8	10	TJ_3_0600	8.3 / 10.3	64	63.6
60	90	8	10	TJ_4_0600	8.3 / 10.3	64	63.6
62	85	10	10	TJ_1_0620	10.3	68	66.4
62	90	10	10	TJ_2_0620	10.3	68	66.4
63	85	10	10	TJ_1_0630	10.3	69	67.4
63	90	10	10	TJ_2_0630	10.3	69	67.4
65	85	10	10	TJ_1_0650	10.3	71	69.4
65	90	10	10	TJ_2_0650	10.3	71	69.4
65	100	10	10	TJ_3_0650	10.3	74	72.4
68	90	10	10	TJ_1_0680	10.3	74	72.4
68	100	10	10	TJ_2_0680	10.3	74	72.4
70	90	10	10	TJ_1_0700	10.3	76	74.4
70	95	10	10	TJ_2_0700	10.3	76	74.4
70	100	10	10	TJ_3_0700	10.3	76	74.4
72	95	10	10	TJ_1_0720	10.3	78	76.4
72	100	10	10	TJ_2_0720	10.3	78	76.4
75	95	10	10	TJ_1_0750	10.3	81	79.4
75	100	10	10	TJ_2_0750	10.3	81	79.4
78	100	10	10	TJ_1_0780	10.3	84	82.4
80	100	10	10	TJ_1_0800	10.3	86	84.4
80	110	10	10	TJ_2_0800	10.3	86	84.4
85	110	12	12	TJ_1_0850	12.4	91	89.4
85	120	12	12	TJ_2_0850	12.4	91	89.4
90	110	12	12	TJ_1_0900	12.4	96	94.4
90	120	12	12	TJ_2_0900	12.4	96	94.4
95	120	12	12	TJ_1_0950	12.4	101	99.4
95	125	12	12	TJ_2_0950	12.4	101	99.4
100	120	12	12	TJ_1_1000	12.4	106	104.4
100	125	12	12	TJ_2_1000	12.4	106	104.4

Sealing lips may, in some cases, protrude beyond the edge of the seal body.

Sizes printed in **bold** are preferred. Sizes not stated on these tables are available on request (note this will include a tooling charge).



Sizes				TSS Part No.	Sizes		
d1 [mm]	d2 [mm]	b [mm] exc. TJB	b [mm] TJB		b1 min. [mm]	d4 max. [mm]	d5 min. [mm]
100	130	12	12	TJ_3_1000	12.4	106	104.4
105	130	12	12	TJ_1_1050	12.4	111	109.4
105	140	12	12	TJ_2_1050	12.4	111	109.4
110	130	12	12	TJ_1_1100	12.4	116	114.4
110	140	12	12	TJ_2_1100	12.4	116	114.4
115	140	12	12	TJ_1_1150	12.4	121	119.4
115	150	12	12	TJ_2_1150	12.4	121	119.4
120	150	12	12	TJ_1_1200	12.4	126	124.4
120	160	12	12	TJ_2_1200	12.4	126	124.4
125	150	12	12	TJ_1_1250	12.4	131	129.4
125	160	12	12	TJ_2_1250	12.4	131	129.4
130	160	12	12	TJ_1_1300	12.4	136	134.4
130	170	12	12	TJ_2_1300	12.4	136	134.4
135	170	12	12	TJ_1_1350	12.4	141	139.4
140	170	15	15	TJ_1_1400	15.4	148	147.0
145	175	15	15	TJ_1_1450	15.4	153	152.0
150	180	15	15	TJ_1_1500	15.4	158	157.0
160	190	15	15	TJ_1_1600	15.4	168	167.0
170	200	15	15	TJ_1_1700	15.4	178	177.0

Sealing lips may, in some cases, protrude beyond the edge of the seal body.
 Sizes printed in **bold** are preferred. Sizes not stated on these tables are available on request (note this will include a tooling charge).



Table 72: Turcon® Varilip® PDR Inch Size Range

Sizes				TSS Part No.	Sizes		
d1 [inch]	d2 [inch]	b [inch] exc. TJB	b [inch] TJB		b1 min. [inch]	d4 max. [inch]	d5 min. [inch]
0.438	0.938	0.276	0.393	TJ_E_D407	0.288 / 0.405	0.595	0.580
0.438	1.063	0.276	0.393	TJ_F_D507	0.288 / 0.405	0.595	0.580
0.438	1.188	0.276	0.393	TJ_G_D607	0.288 / 0.405	0.595	0.580
0.438	1.313	0.276	0.393	TJ_H_D707	0.288 / 0.405	0.595	0.580
0.438	1.438	0.276	0.393	TJ_J_D807	0.288 / 0.405	0.595	0.580
0.500	1.000	0.276	0.393	TJ_E_D408	0.288 / 0.405	0.657	0.642
0.500	1.125	0.276	0.393	TJ_F_D508	0.288 / 0.405	0.657	0.642
0.500	1.250	0.276	0.393	TJ_G_D608	0.288 / 0.405	0.657	0.642
0.500	1.375	0.276	0.393	TJ_H_D708	0.288 / 0.405	0.657	0.642
0.500	1.500	0.276	0.393	TJ_J_D(08)	0.288 / 0.405	0.657	0.642
0.563	1.063	0.276	0.393	TJ_E_D409	0.288 / 0.405	0.720	0.705
0.563	1.188	0.276	0.393	TJ_F_D509	0.288 / 0.405	0.720	0.705
0.563	1.313	0.276	0.393	TJ_G_D609	0.288 / 0.405	0.720	0.705
0.563	1.438	0.276	0.393	TJ_H_D709	0.288 / 0.405	0.720	0.705
0.563	1.563	0.276	0.393	TJ_J_D809	0.288 / 0.405	0.720	0.705
0.625	1.125	0.276	0.393	TJ_E_D410	0.288 / 0.405	0.782	0.767
0.625	1.250	0.276	0.393	TJ_F_D510	0.288 / 0.405	0.782	0.767
0.625	1.375	0.276	0.393	TJ_G_D610	0.288 / 0.405	0.782	0.767
0.625	1.500	0.276	0.393	TJ_H_D710	0.288 / 0.405	0.782	0.767
0.625	1.625	0.276	0.393	TJ_J_D810	0.288 / 0.405	0.782	0.767
0.688	1.188	0.276	0.393	TJ_E_D411	0.288 / 0.405	0.845	0.830
0.688	1.313	0.276	0.393	TJ_F_D511	0.288 / 0.405	0.845	0.830
0.688	1.438	0.276	0.393	TJ_G_D611	0.288 / 0.405	0.845	0.830
0.688	1.563	0.276	0.393	TJ_H_D711	0.288 / 0.405	0.845	0.830
0.688	1.688	0.276	0.393	TJ_J_D811	0.288 / 0.405	0.845	0.830
0.750	1.250	0.276	0.393	TJ_E_D412	0.288 / 0.405	0.907	0.892
0.750	1.375	0.276	0.393	TJ_F_D512	0.288 / 0.405	0.907	0.892
0.750	1.500	0.276	0.393	TJ_G_D612	0.288 / 0.405	0.907	0.892
0.750	1.625	0.276	0.393	TJ_H_D712	0.288 / 0.405	0.907	0.892
0.750	1.750	0.276	0.393	TJ_J_D812	0.288 / 0.405	0.907	0.892
0.813	1.313	0.276	0.393	TJ_E_D413	0.288 / 0.405	0.970	0.955
0.813	1.438	0.276	0.393	TJ_F_D513	0.288 / 0.405	0.970	0.955
0.813	1.563	0.276	0.393	TJ_G_D613	0.288 / 0.405	0.970	0.955
0.813	1.688	0.276	0.393	TJ_H_D713	0.288 / 0.405	0.970	0.955
0.813	1.813	0.276	0.393	TJ_J_D813	0.288 / 0.405	0.970	0.955
0.875	1.375	0.276	0.393	TJ_E_D414	0.288 / 0.405	1.032	1.017
0.875	1.500	0.276	0.393	TJ_F_D514	0.288 / 0.405	1.032	1.017
0.875	1.625	0.276	0.393	TJ_G_D614	0.288 / 0.405	1.032	1.017

Sealing lips may, in some cases, protrude beyond the edge of the seal body.

Sizes printed in **bold** are preferred. Sizes not stated on these tables are available on request (note this will include a tooling charge).



Sizes				TSS Part No.	Sizes		
d1 [inch]	d2 [inch]	b [inch] exc. TJB	b [inch] TJB		b1 min. [inch]	d4 max. [inch]	d5 min. [inch]
0.875	1.750	0.276	0.393	TJ_H_D714	0.288 / 0.405	1.032	1.017
0.875	1.875	0.276	0.393	TJ_J_D814	0.288 / 0.405	1.032	1.017
0.938	1.438	0.276	0.393	TJ_E_D415	0.288 / 0.405	1.095	1.080
0.938	1.563	0.276	0.393	TJ_F_D515	0.288 / 0.405	1.095	1.080
0.938	1.688	0.276	0.393	TJ_G_D615	0.288 / 0.405	1.095	1.080
0.938	1.813	0.276	0.393	TJ_H_D715	0.288 / 0.405	1.095	1.080
0.938	1.938	0.276	0.393	TJ_J_D815	0.288 / 0.405	1.095	1.080
1.000	1.500	0.276	0.393	TJ_E_D416	0.288 / 0.405	1.157	1.142
1.000	1.625	0.276	0.393	TJ_F_D516	0.288 / 0.405	1.157	1.142
1.000	1.750	0.276	0.393	TJ_G_D616	0.288 / 0.405	1.157	1.142
1.000	1.875	0.276	0.393	TJ_H_D716	0.288 / 0.405	1.157	1.142
1.000	2.000	0.276	0.393	TJ_J_D816	0.288 / 0.405	1.157	1.142
1.125	1.625	0.276	0.393	TJ_E_D418	0.288 / 0.405	1.282	1.267
1.125	1.750	0.276	0.393	TJ_F_D518	0.288 / 0.405	1.282	1.267
1.125	1.875	0.276	0.393	TJ_G_D618	0.288 / 0.405	1.282	1.267
1.125	2.000	0.276	0.393	TJ_H_D718	0.288 / 0.405	1.282	1.267
1.125	2.125	0.276	0.393	TJ_J_D818	0.288 / 0.405	1.282	1.267
1.250	1.750	0.276	0.393	TJ_E_D420	0.288 / 0.405	1.407	1.392
1.250	1.875	0.276	0.393	TJ_F_D520	0.288 / 0.405	1.407	1.392
1.250	2.000	0.276	0.393	TJ_G_D620	0.288 / 0.405	1.407	1.392
1.250	2.125	0.276	0.393	TJ_J_D820	0.288 / 0.405	1.407	1.392
1.250	2.250	0.276	0.393	TJ_J_D820	0.288 / 0.405	1.407	1.392
1.375	1.875	0.276	0.393	TJ_E_D422	0.288 / 0.405	1.532	1.517
1.375	2.000	0.276	0.393	TJ_F_D522	0.288 / 0.405	1.532	1.517
1.375	2.125	0.276	0.393	TJ_G_D622	0.288 / 0.405	1.532	1.517
1.375	2.250	0.276	0.393	TJ_H_D722	0.288 / 0.405	1.532	1.517
1.375	2.375	0.276	0.393	TJ_J_D822	0.288 / 0.405	1.532	1.517
1.500	2.000	0.276	0.393	TJ_E_D424	0.288 / 0.405	1.657	1.642
1.500	2.125	0.276	0.393	TJ_F_D524	0.288 / 0.405	1.657	1.642
1.500	2.250	0.276	0.393	TJ_G_D624	0.288 / 0.405	1.657	1.642
1.500	2.375	0.276	0.393	TJ_H_D724	0.288 / 0.405	1.657	1.642
1.500	2.500	0.276	0.393	TJ_J_D824	0.288 / 0.405	1.657	1.642
1.625	2.125	0.276	0.393	TJ_E_D426	0.288 / 0.405	1.782	1.767
1.625	2.250	0.276	0.393	TJ_F_D526	0.288 / 0.405	1.782	1.767
1.625	2.375	0.276	0.393	TJ_G_D626	0.288 / 0.405	1.782	1.767
1.625	2.500	0.276	0.393	TJ_H_D726	0.288 / 0.405	1.782	1.767
1.625	2.625	0.276	0.393	TJ_J_D826	0.288 / 0.405	1.782	1.767
1.750	2.250	0.276	0.393	TJ_E_D428	0.288 / 0.405	1.907	1.892
1.750	2.375	0.276	0.393	TJ_F_D528	0.288 / 0.405	1.907	1.892
1.750	2.500	0.276	0.393	TJ_G_D628	0.288 / 0.405	1.907	1.892

Sealing lips may, in some cases, protrude beyond the edge of the seal body.
 Sizes printed in **bold** are preferred. Sizes not stated on these tables are available on request (note this will include a tooling charge).



Sizes				TSS Part No.	Sizes		
d1 [inch]	d2 [inch]	b [inch] exc. TJB	b [inch] TJB		b1 min. [inch]	d4 max. [inch]	d5 min. [inch]
1.750	2.625	0.276	0.393	TJ_H_D728	0.288 / 0.405	1.907	1.892
1.750	2.750	0.276	0.393	TJ_J_D828	0.288 / 0.405	1.907	1.892
1.875	2.375	0.276	0.393	TJ_E_D430	0.288 / 0.405	2.032	2.017
1.875	2.500	0.276	0.393	TJ_F_D530	0.288 / 0.405	2.032	2.017
1.875	2.625	0.276	0.393	TJ_G_D630	0.288 / 0.405	2.032	2.017
1.875	2.750	0.276	0.393	TJ_H_D730	0.288 / 0.405	2.032	2.017
1.875	2.875	0.276	0.393	TJ_J_D830	0.288 / 0.405	2.032	2.017
2.000	2.500	0.276	0.393	TJ_E_D432	0.288 / 0.405	2.157	2.142
2.000	2.625	0.276	0.393	TJ_F_D532	0.288 / 0.405	2.157	2.142
2.000	2.750	0.276	0.393	TJ_G_D632	0.288 / 0.405	2.157	2.142
2.000	2.875	0.276	0.393	TJ_H_D732	0.288 / 0.405	2.157	2.142
2.000	3.000	0.276	0.393	TJ_J_D832	0.288 / 0.405	2.157	2.142
2.125	2.625	0.276	0.393	TJ_E_D434	0.288 / 0.405	2.282	2.267
2.125	2.750	0.276	0.393	TJ_F_D534	0.288 / 0.405	2.282	2.267
2.125	2.875	0.276	0.393	TJ_G_D634	0.288 / 0.405	2.282	2.267
2.125	3.000	0.276	0.393	TJ_H_D734	0.288 / 0.405	2.282	2.267
2.125	3.125	0.276	0.393	TJ_J_D834	0.288 / 0.405	2.282	2.267
2.250	2.750	0.276	0.393	TJ_E_D436	0.288 / 0.405	2.407	2.392
2.250	2.875	0.276	0.393	TJ_F_D536	0.288 / 0.405	2.407	2.392
2.250	3.000	0.276	0.393	TJ_G_D636	0.288 / 0.405	2.407	2.392
2.250	3.125	0.276	0.393	TJ_H_D736	0.288 / 0.405	2.407	2.392
2.250	3.250	0.276	0.393	TJ_J_D836	0.288 / 0.405	2.407	2.392
2.375	2.875	0.276	0.393	TJ_E_D438	0.288 / 0.405	2.532	2.517
2.375	3.000	0.276	0.393	TJ_F_D538	0.288 / 0.405	2.532	2.517
2.375	3.125	0.276	0.393	TJ_G_D638	0.288 / 0.405	2.532	2.517
2.375	3.250	0.276	0.393	TJ_H_D738	0.288 / 0.405	2.532	2.517
2.375	3.375	0.276	0.393	TJ_J_D838	0.288 / 0.405	2.532	2.517
2.500	3.000	0.315	0.393	TJ_E_D440	0.327 / 0.405	2.657	2.642
2.500	3.125	0.315	0.393	TJ_F_D540	0.327 / 0.405	2.657	2.642
2.500	3.250	0.315	0.393	TJ_G_D640	0.327 / 0.405	2.657	2.642
2.500	3.375	0.315	0.393	TJ_H_D740	0.327 / 0.405	2.657	2.642
2.500	3.500	0.315	0.393	TJ_J_D840	0.327 / 0.405	2.657	2.642
2.625	3.125	0.315	0.393	TJ_E_D442	0.327 / 0.405	2.861	2.798
2.625	3.250	0.315	0.393	TJ_F_D542	0.327 / 0.405	2.861	2.798
2.625	3.375	0.315	0.393	TJ_G_D642	0.327 / 0.405	2.861	2.798
2.625	3.500	0.315	0.393	TJ_H_D742	0.327 / 0.405	2.861	2.798
2.625	3.625	0.315	0.393	TJ_J_D842	0.327 / 0.405	2.861	2.798
2.750	3.250	0.315	0.393	TJ_E_D444	0.327 / 0.405	2.986	2.923
2.750	3.375	0.315	0.393	TJ_F_D544	0.327 / 0.405	2.986	2.923
2.750	3.500	0.315	0.393	TJ_G_D644	0.327 / 0.405	2.986	2.923

Sealing lips may, in some cases, protrude beyond the edge of the seal body.

Sizes printed in **bold** are preferred. Sizes not stated on these tables are available on request (note this will include a tooling charge).



Sizes				TSS Part No.	Sizes		
d1 [inch]	d2 [inch]	b [inch] exc. TJB	b [inch] TJB		b1 min. [inch]	d4 max. [inch]	d5 min. [inch]
2.750	3.625	0.315	0.393	TJ_H_D744	0.327 / 0.405	2.986	2.923
2.750	3.750	0.315	0.393	TJ_J_D844	0.327 / 0.405	2.986	2.923
2.875	3.375	0.315	0.393	TJ_E_D446	0.327 / 0.405	3.111	3.048
2.875	3.500	0.315	0.393	TJ_F_D546	0.327 / 0.405	3.111	3.048
2.875	3.625	0.315	0.393	TJ_G_D646	0.327 / 0.405	3.111	3.048
2.875	3.750	0.315	0.393	TJ_H_D746	0.327 / 0.405	3.111	3.048
2.875	3.875	0.315	0.393	TJ_J_D846	0.327 / 0.405	3.111	3.048
3.000	3.500	0.315	0.393	TJ_E_D448	0.327 / 0.405	3.236	3.173
3.000	3.625	0.315	0.393	TJ_F_D548	0.327 / 0.405	3.236	3.173
3.000	3.750	0.315	0.393	TJ_G_D648	0.327 / 0.405	3.236	3.173
3.000	3.875	0.315	0.393	TJ_H_D748	0.327 / 0.405	3.236	3.173
3.000	4.000	0.315	0.393	TJ_J_D848	0.327 / 0.405	3.236	3.173
3.125	3.625	0.315	0.393	TJ_E_D450	0.327 / 0.405	3.361	3.298
3.125	3.750	0.315	0.393	TJ_F_D550	0.327 / 0.405	3.361	3.298
3.125	3.875	0.315	0.393	TJ_G_D650	0.327 / 0.405	3.361	3.298
3.125	4.000	0.315	0.393	TJ_H_D750	0.327 / 0.405	3.361	3.298
3.125	4.125	0.315	0.393	TJ_J_D850	0.327 / 0.405	3.361	3.298
3.250	3.875	0.315	0.393	TJ_F_D552	0.327 / 0.405	3.486	3.423
3.250	4.000	0.315	0.393	TJ_G_D652	0.327 / 0.405	3.486	3.423
3.250	4.125	0.315	0.393	TJ_H_D752	0.327 / 0.405	3.486	3.423
3.250	4.250	0.315	0.393	TJ_J_D852	0.327 / 0.405	3.486	3.423
3.375	4.000	0.472	0.472	TJ_F_D554	0.484	3.611	3.548
3.375	4.125	0.472	0.472	TJ_G_D654	0.484	3.611	3.548
3.375	4.250	0.472	0.472	TJ_H_D754	0.484	3.611	3.548
3.375	4.375	0.472	0.472	TJ_J_D854	0.484	3.611	3.548
3.500	4.125	0.472	0.472	TJ_F_D556	0.484	3.736	3.673
3.500	4.250	0.472	0.472	TJ_G_D656	0.484	3.736	3.673
3.500	4.375	0.472	0.472	TJ_H_D756	0.484	3.736	3.673
3.500	4.500	0.472	0.472	TJ_J_D856	0.484	3.736	3.673
3.625	4.250	0.472	0.472	TJ_F_D558	0.484	3.861	3.798
3.625	4.375	0.472	0.472	TJ_G_D658	0.484	3.861	3.798
3.625	4.500	0.472	0.472	TJ_H_D758	0.484	3.861	3.798
3.625	4.625	0.472	0.472	TJ_J_D858	0.484	3.861	3.798
3.750	4.375	0.472	0.472	TJ_F_D560	0.484	3.986	3.923
3.750	4.500	0.472	0.472	TJ_G_D660	0.484	3.986	3.923
3.750	4.625	0.472	0.472	TJ_H_D760	0.484	3.986	3.923
3.750	4.750	0.472	0.472	TJ_J_D860	0.484	3.986	3.923
3.875	4.500	0.472	0.472	TJ_F_D562	0.484	4.111	4.048
3.875	4.625	0.472	0.472	TJ_G_D662	0.484	4.111	4.048
3.875	4.750	0.472	0.472	TJ_H_D762	0.484	4.111	4.048

Sealing lips may, in some cases, protrude beyond the edge of the seal body.
 Sizes printed in **bold** are preferred. Sizes not stated on these tables are available on request (note this will include a tooling charge).



Sizes				TSS Part No.	Sizes		
d1 [inch]	d2 [inch]	b [inch] exc. TJB	b [inch] TJB		b1 min. [inch]	d4 max. [inch]	d5 min. [inch]
3.875	4.875	0.472	0.472	TJ_J_D862	0.484	4.111	4.048
4.000	4.625	0.472	0.472	TJ_F_D564	0.484	4.236	4.173
4.000	4.750	0.472	0.472	TJ_G_D664	0.484	4.236	4.173
4.000	4.875	0.472	0.472	TJ_H_D764	0.484	4.236	4.173
4.000	5.000	0.472	0.472	TJ_J_D864	0.484	4.236	4.173
4.125	4.750	0.472	0.472	TJ_F_D566	0.484	4.361	4.298
4.125	4.875	0.472	0.472	TJ_G_D666	0.484	4.361	4.298
4.125	5.000	0.472	0.472	TJ_H_D766	0.484	4.361	4.298
4.125	5.125	0.472	0.472	TJ_J_D866	0.484	4.361	4.298

Sealing lips may, in some cases, protrude beyond the edge of the seal body.

Sizes printed in **bold** are preferred. Sizes not stated on these tables are available on request (note this will include a tooling charge).



■ Ordering Information

An ordering example is shown below.

ORDERING EXAMPLE STANDARD, TYPE A/TYPE 1

Shaft diameter:	d1 = 30 mm (1.181 in)
Outside diameter:	d2 = 47 mm (1.85 in)
Width:	b = 7 mm (0.276 in)

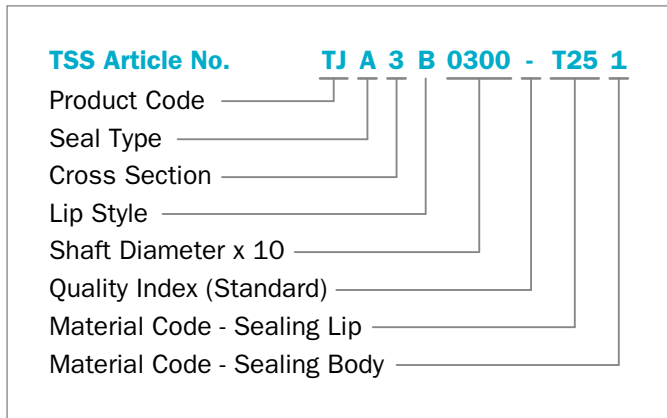

Order as:	TJA380300-T251V
Type:	A, B, C, D, or G 1, 3, 4, 5, or 6
Cross-Section-Ø:	1, 2, 3, 4, 5, 6 or 7 Refer to Table of Sizes
Lip Style:	A, B, or C
(Shaft rotation viewed from airside)	A anti-clockwise shaft B bi-directional shaft C clockwise shaft
Shaft x 10:	Refer to Table of Sizes
Quality Index:	For standard parts A for aerospace parts
Lip Material:	Refer to Materials section
Case Material:	1*

* Other materials available on request

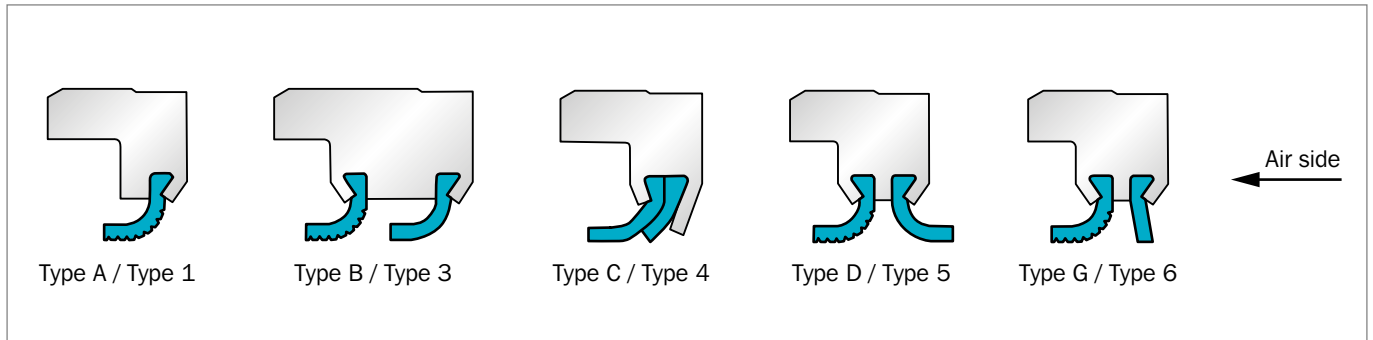

Figure 116: Product Range

Turcon[®] and Zurcon[®] Roto Seals





Turcon[®] Roto Glyd Ring[®]







■ Turcon® Roto Glyd Ring®

■ General Description

Double-acting Turcon® Roto Glyd Ring® is used to seal shafts, axles, cylinder bores, rotary manifolds, and swivels with rotary, helical or oscillating movement. It consists of a seal ring in high-grade Turcon® material activated by an elastomeric O-Ring.

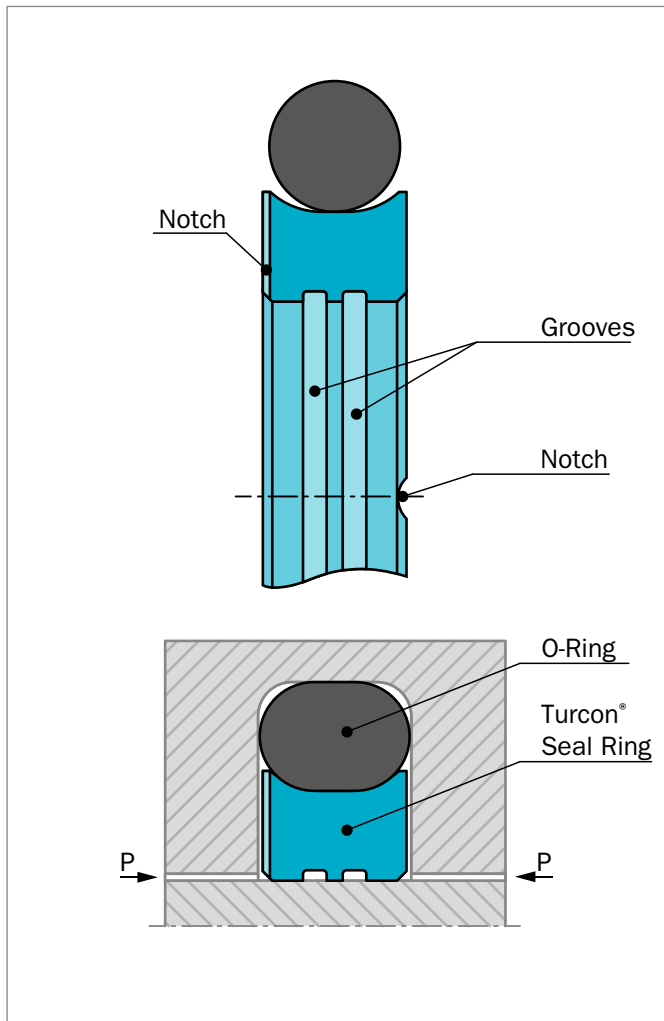

Figure 117: Turcon® Roto Glyd Ring®

The contact surface profile of the seal ring is specially designed for use at high-pressure and low sliding speeds.

METHOD OF OPERATION

The double acting performance of the seal follows from the symmetrical cross section which allows the seal to respond to pressure in both directions.

Initial contact pressure is provided by radial compression of the O-Ring. When the system pressure is increased the O-Ring transforms this into additional contact pressure, the contact pressure of the seal is thereby automatically adjusted so sealing is ensured under all service conditions.

Depending on the profile cross-section of the seal, the contact surface has none, one or two continuous machined grooves. These improve seal efficiency by increasing the specific surface load pressure against the sealed surface. They also form a lubricant reservoir and reduce friction.

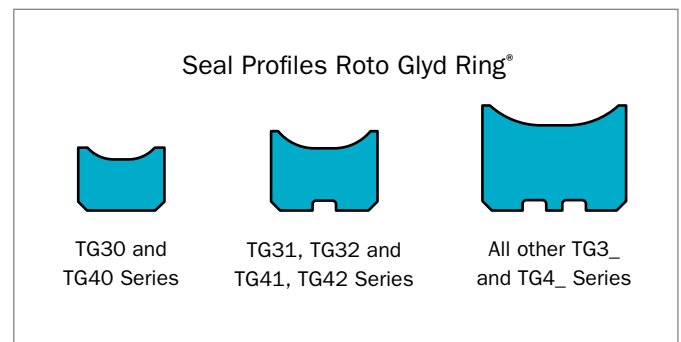

Figure 118: Crosssection profiles depending on Series No.

NOTCH

To assure rapid activation of the seal at sudden changes of pressure and direction of motion, radial notches are added on both sides of the seal ring.

ADVANTAGES

- Initial contact pressure of Roto Glyd Ring® is available for shaft and bore sealing applications
- Double-acting seal
- Low friction
- Lubricant reservoir
- Stick-slip free operation
- No vulcanizing to mating surfaces
- Simple groove design
- Small groove dimensions
- For use at high-pressure and low sliding-speeds
- Available in all sizes up to 2.700 mm diameter (to 2.600 mm for shaft seals)



TYPICAL APPLICATIONS

Roto Glyd Ring® is used as a double acting rotary seal for hydraulic and pneumatic equipment in sectors such as:

- Rotary distributors and unions
- High pressure valve stems
- Manipulators
- Pivoting motors in mobile hydraulics and machine tools
- Hydraulic motors
- Blow molding machines
- Top drives
- Rotary tables
- FPSO swivel units
- Core cutting equipment

OPERATING CONDITIONS

Seal performance is influenced by such factors as lubrication capability of the sealed medium and heat dissipation in the hardware. It follows that testing should always be made. With good lubrication, the following values can be used:

Pressure:	Up to 30 MPa
Speed:	Up to 0.2 m/s
PV:	Up to 2.5 MPa m/s The value must be reduced for diameters < 50 mm.
Temperature:	-45 °C to +200 °C* depending on O-Ring elastomer and medium
Media:	Mineral oil-based hydraulic fluids, flame retardant hydraulic fluids, environmentally-friendly hydraulic fluids (bio-oils), water and others depending on seal and elastomer material.

IMPORTANT NOTE

The above data are maximum values and cannot be used at the same time, e. g. the maximum operating speed depends on material type, pressure and temperature and gap value. Temperature range also dependant on media.

*) IMPORTANT NOTE FOR THE BORE VERSION

In the case on unpressurized applications in temperatures below 0 °C please contact your local Trelleborg Sealing Solutions marketing company for more information.

FRICITIONAL POWER

Guide values for the frictional power P can be determined from the graph in Figure 119. They are shown as a function of the sliding speed and operating pressure for a shaft diameter of 50 mm / 1.968 inch with an oil temperature of +60 °C. At higher temperatures, these application limits must be reduced.

Formula for other diameters d:

$$P = \frac{P_{50} \times (d) [W]}{(50 \text{ mm})}$$

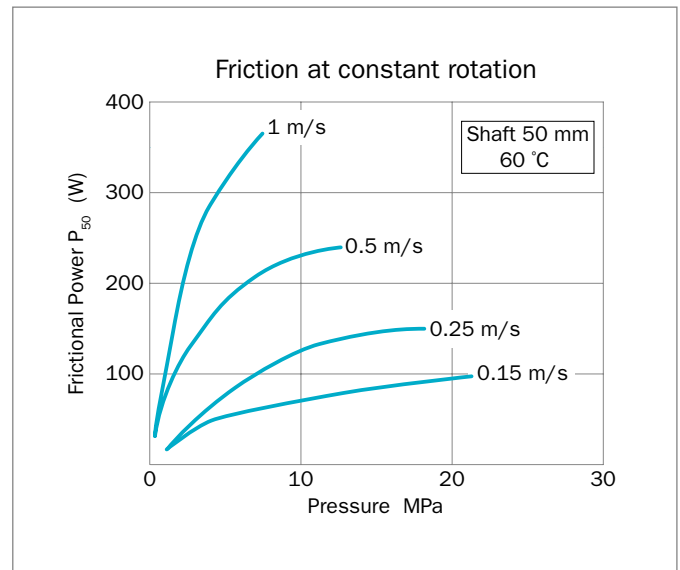

Figure 119: Frictional power for Turcon® Roto Glyd Ring®

The guide values apply for constant operating conditions. Changes in operating conditions such as pressure fluctuations or alternating directions of shaft rotation can result in considerably higher friction values.

INSTALLATION INSTRUCTIONS

Roto Glyd Ring® is installed according to information starting at page 309.

Closed groove installation according to dimensions at Table 74, page 230.



RECOMMENDED MATERIALS

The following material combinations have proven effective for rotary applications:

Turcon® Roto Glyd Ring® in Turcon® T40

All-round material in lubricating fluids and fluids with limited lubrication e. g. water:

O-Ring: NBR 70 Shore A N
 FKM 70 Shore A V
 HNBR 70 Shore A H
 (according to temperature)

Set code: T40N, T40V or T40H

Turcon® Roto Glyd Ring® in Turcon® M15

Material for light to medium applications with high sealing effect in fluids with good lubrication:

O-Ring: NBR 70 Shore A N
 FKM 70 Shore A V
 HNBR 70 Shore A H
 (according to temperature)

Set code: M15N, M15V or M15H

Turcon® Roto Glyd Ring® in Zurcon® Z80

For slow turning applications with fluids, air, gases and risk of high abrasive wear; temperature limit -45 °C to +80 °C:

O-Ring NBR 70 Shore A

Set code: Z80N

Z80 are for slow turning motion and not for constant rotation.

For specific applications other Turcon® and Zurcon® materials are available.



Table 73: Turcon® Materials

Material, Applications, Properties	Code	O-Ring Material Shore A	Code	O-Ring Operating Temp.* °C	Mating Surface Material	MPa max. Dynamic
Turcon® M12 For lubricated applications High compressive strength Low friction Tight surface texture High sealing effect Good sliding properties Good extrusion resistance Mineral filled Color: Dark green-gray	M12	NBR 70	N	-30 to +100	Steel hardend	15
		NBR 70 Low temp.	T	-45 to +80	Steel, chrome plated (shaft) Cast iron	
		FKM 70	V	-10 to +200		
		HNBR 70	H	-30 to +150		
Turcon® M15 For lubricating fluids and fluids with low lubricating properties Excellent for rotary service High sealing effect Very good wear properties Low friction Polyaramid, mineral fiber, lubricant and graphite filled Color: Dark gray	M15	NBR 70	N	-30 to +100	Steel hardend	25
		NBR 70 Low temp.	T	-45 to +80	Steel chrome plated (shaft) Cast iron	
		FKM 70	V	-10 to +200		
		HNBR 70	H	-30 to +150		
Turcon® T10 Hydraulics and pneumatics for lubricating and non-lubricating fluids High extrusion resistance Good chemical resistance BAM tested Carbon graphite filled Color: Black	T10	NBR 70	N	-30 to +100	Steel hardend	15
		NBR 70 Low temp.	T	-45 to +80	Steel, chrome plated Cast iron	
		FKM 70	V	-10 to +200		
		HNBR 70	H	-30 to +150		
Turcon® M40 All round material for rotary and turning movements For lubricating fluids and fluids with low lubricating properties, e.g. water Surface texture not suitable for gases Carbon fiber filled Color: Gray	T40	NBR 70	N	-30 to +100	Steel	30
		NBR 70 Low temp.	T	-45 to +80	Steel chrome plated Cast iron	
		FKM 70	V	-10 to +200	Stainles steel Hard Alloys	
		HNBR 70	H	-30 to +150		

Table is continued on next page



Material, Applications, Properties	Code	O-Ring Material Shore A	Code	O-Ring Operating Temp.* °C	Mating Surface Material	MPa max. Dynamic
Zurcon® Z80 For lubricating fluids and fluids with low lubricating properties, e.g. water, air and gases at low pressure Good abrasion resistance Good chemical resistance Not for constant rotation Max. working temperature +80 °C Ultra high molecular weight polyethylene Color: White to off-white	Z80	NBR 70	N	-30 to +80	Steel	20
		FKM 70	T	-10 to +80	Steel chrome plated Stainles steel Ceramic coating	

* The O-Ring operation temperature is only valid in mineral hydraulic oil.

BAM: Approved by "Bundesanstalt Materialprüfung, Germany".

Highlighted materials are recommended.



■ Installation Recommendation for Shaft

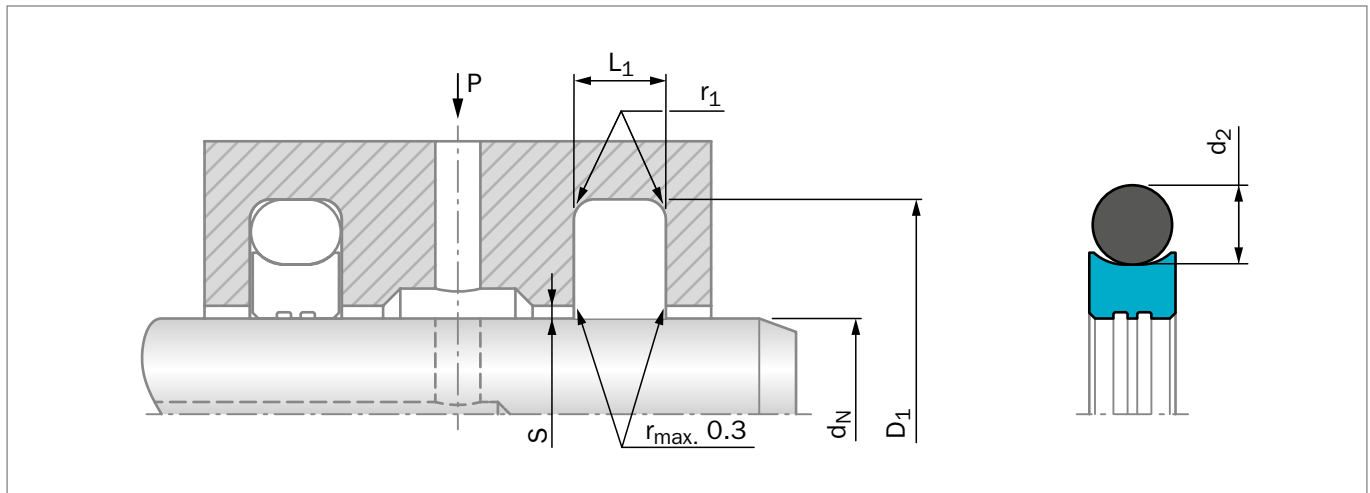

Figure 120: Installation Drawing

Table 74: Installation Dimensions – Standard Recommendations

Series Number	Shaft Diameter d_N f8/h9		Groove Diameter D_1 H9	Groove Width $L_1 +0.2$	Radius r_1	Radial Clearance S_{max}^*			O-Ring Cross-Section- \emptyset d_2	No. of Grooves in the Sealing Surface
	Recommended Range	Available Range				10 MPa	20 MPa	30 MPa		
TG30	6 - 18.9	6 - 130.0	$d_N + 4.9$	2.20	0.40	0.20	0.15	-	1.78	0
TG31	19 - 37.9	10 - 245.0	$d_N + 7.5$	3.20	0.60	0.25	0.20	0.15	2.62	1
TG32	19 - 37.9	19 - 455.0	$d_N + 11.0$	4.20	1.00	0.30	0.25	0.20	3.53	1
TG33	200 - 255.9	38 - 655.0	$d_N + 15.5$	6.30	1.30	0.35	0.30	0.25	5.33	2
TG34	256 - 649.9	120 - 655.0	$d_N + 21.0$	8.10	1.80	0.40	0.35	0.30	7.00	2
TG35	650 - 999.9	650 - 999.9	$d_N + 28.0$	9.50	2.50	0.45	0.40	0.35	8.40	2
TG35X	1,000 - 2,600	-	$d_N + 28.0$	9.50	2.50	0.45	0.40	0.35	8.40	2

* At pressures > 30 MPa: Use diameter tolerance H8/f8 (bore/shaft) in area of seal.

At pressures > 10 MPa it is recommendable to choose the next larger cross section according to the column "Available range" i.e. for shaft $\emptyset d_N = 80$ mm: TG33 00 800-.

ORDERING EXAMPLE

Turcon® Roto Glyd Ring®, complete with O-Ring, standard application:

Series: TG32 from Table 74
Shaft diameter: $d_N = 80.0$ mm
TSS Part No.: TG3200800 from Table 75

Select the material from Table 73. The corresponding code numbers are appended to the TSS Part No. Together they form the TSS Article No. The TSS Article No. for all intermediate sizes not shown in Table 75 can be determined following the example opposite.

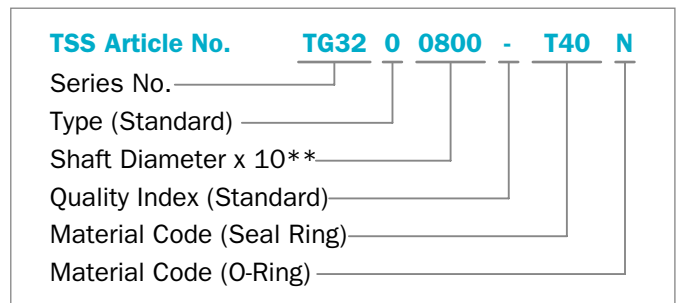

** For diameters $\geq 1,000.0$ mm multiply only by factor 1.
 Example: TG35X for diameter 1,200.0 mm
 TSS Article No.: TG35X1200 – T40N



Table 75: Standard Installation Dimensions / TSS Part Number

Shaft Dia.	Groove Dia.	Groove Width	TSS Part No.	O-Ring Sizes	Shaft Dia.	Groove Dia.	Groove Width	TSS Part No.	O-Ring Sizes
d_N f8/h9	D_1 H9	L_1 +0.20			d_N f8/h9	D_1 H9	L_1 +0.20		
6.0	10.9	2.2	TG3000060	7.65 x 1.78	140.0	155.5	6.3	TG3301400	145.42 x 5.33
10.0	14.9	2.2	TG3000100	11.80 x 1.80	150.0	161.0	4.2	TG3201500	158.34 x 3.53
12.0	16.9	2.2	TG3000120	13.20 x 1.80	150.0	165.5	6.3	TG3301500	158.12 x 5.33
14.0	18.9	2.2	TG3000140	15.60 x 1.78	150.0	171.0	8.1	TG3401500	158.12 x 7.00
15.0	19.0	2.2	TG3000150	17.17 x 1.78	160.0	171.0	4.2	TG3201600	164.69 x 3.53
16.0	20.9	2.2	TG3000160	17.17 x 1.78	170.0	181.0	4.2	TG3201700	177.39 x 3.53
18.0	22.9	2.2	TG3000180	19.00 x 1.80	180.0	191.0	4.2	TG3201800	183.74 x 3.53
20.0	24.9	3.2	TG3000200	21.95 x 1.78	190.0	201.0	4.2	TG3201900	196.44 x 3.53
20.0	27.5	3.2	TG3100200	21.89 x 2.62	200.0	215.5	6.3	TG3302000	208.92 x 5.33
22.0	29.5	3.2	TG3100220	25.07 x 2.62	210.0	225.5	6.3	TG3302100	215.27 x 5.33
25.0	29.5	2.2	TG3000250	26.70 x 1.78	220.0	235.5	6.3	TG3302200	227.97 x 5.33
25.0	32.5	3.2	TG3100250	28.24 x 2.62	230.0	245.5	6.3	TG3302300	234.32 x 5.33
28.0	35.5	3.2	TG3100280	31.42 x 2.62	250.0	271.0	8.1	TG3402500	266.07 x 7.00
30.0	37.5	3.2	TG3100300	32.99 x 2.62	280.0	301.0	8.1	TG3402800	291.47 x 7.00
32.0	39.5	3.2	TG3100320	34.59 x 2.62	300.0	321.0	8.1	TG3403000	304.17 x 7.00
35.0	42.5	3.2	TG3100350	37.77 x 2.62	320.0	341.0	8.1	TG3403200	329.57 x 7.00
36.0	43.5	3.2	TG3100360	39.34 x 2.62	350.0	365.5	6.3	TG3303500	354.97 x 5.33
40.0	47.5	3.2	TG3100400	42.52 x 2.62	350.0	371.0	8.1	TG3403500	354.97 x 7.00
40.0	51.0	4.2	TG3200400	44.04 x 3.53	360.0	381.0	8.1	TG3403600	367.67 x 7.00
45.0	56.0	4.2	TG3200450	50.39 x 3.53	400.0	421.0	8.1	TG3404000	405.26 x 7.00
50.0	61.0	4.2	TG3200500	53.57 x 3.53	500.0	521.0	8.1	TG3405000	506.86 x 7.00
55.0	66.0	4.2	TG3200550	59.92 x 3.53	600.0	621.0	8.1	TG3406000	608.08 x 7.00
56.0	67.0	4.2	TG3200560	59.92 x 3.53	650.0	678.0	9.5	TG3506500	662.90 x 8.40
60.0	67.5	3.2	TG3100600	63.17 x 2.62	700.0	728.0	9.5	TG3507000	713.00 x 8.40
60.0	71.0	4.2	TG3200600	63.09 x 3.53	800.0	828.0	9.5	TG3508000	813.00 x 8.40
63.0	74.0	4.2	TG3200630	66.27 x 3.53	900.0	928.0	9.5	TG3509000	913.00 x 8.40
70.0	81.0	4.2	TG3200700	75.79 x 3.53	950.0	978.0	9.5	TG3509500	962.00 x 8.40
75.0	86.0	4.2	TG3200750	78.97 x 3.53	950.0	978.0	9.5	TG3509500	962.00 x 8.40
80.0	91.0	4.2	TG3200800	85.32 x 3.53	1,500.0	1,528.0	9.5	TG35X1500	1,513.00 x 8.40
85.0	96.0	4.2	TG3200850	88.49 x 3.53	2,000.0	2,028.0	9.5	TG35X2000	2,013.00 x 8.40
90.0	101.0	4.2	TG3200900	94.84 x 3.53	2,500.0	2,528.0	9.5	TG35X2500	2,513.00 x 8.40
95.0	106.0	4.2	TG3200950	101.19 x 3.53					
100.0	111.0	4.2	TG3201000	104.37 x 3.53					
105.0	116.0	4.2	TG3201050	110.72 x 3.53					
110.0	121.0	4.2	TG3201100	113.89 x 3.53					
120.0	131.0	4.2	TG3201200	123.42 x 3.53					
125.0	136.0	4.2	TG3201250	129.77 x 3.53					
130.0	137.5	3.2	TG3101300	133.02 x 2.62					
130.0	141.0	4.2	TG3201300	136.12 x 3.53					
135.0	146.0	4.2	TG3201350	139.29 x 3.53					
140.0	151.0	4.2	TG3201400	145.64 x 3.53					

The shaft diameters in **bold** type correspond to the recommendations of ISO 3320.

Other dimensions and all intermediate sizes up to 2,600 mm diameter including imperial (inch) sizes can be supplied.



■ Installation Recommendation for Bore

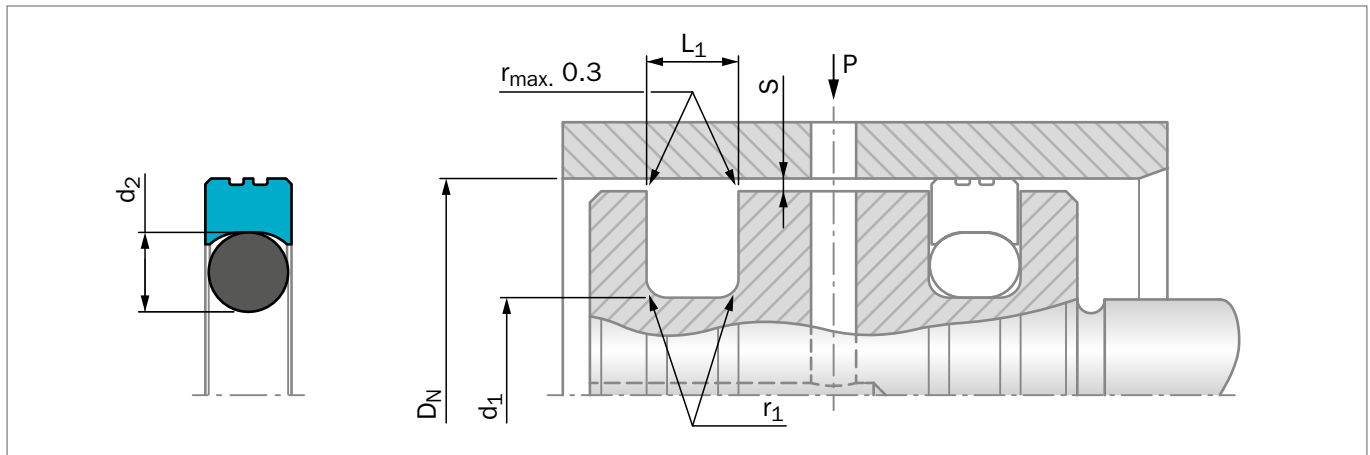

Figure 121: Installation Drawing

Table 76: Installation Dimensions – Standard Recommendations

Series Number	Bore Diameter D_N H9		Groove Diameter d_1 h9	Groove Width $L_1 +0.2$	Radius r_1	Radial Clearance S_{max}^*			O-Ring Cross-Section- \emptyset d_2	No. of Grooves in the Sealing Surface
	Recommended Range	Available Range				10 MPa	20 MPa	30 MPa		
TG40	8 - 39.9	8 - 135.0	$D_N - 4.9$	2.20	0.40	0.20	0.15	-	1.78	0
TG41	40 - 79.9	14 - 250.0	$D_N - 7.5$	3.20	0.60	0.25	0.20	0.15	2.62	1
TG42	80 - 132.9	22 - 460.0	$D_N - 11.0$	4.20	1.00	0.30	0.25	0.20	3.53	1
TG43	133 - 329.9	40 - 675.0	$D_N - 15.5$	6.30	1.30	0.35	0.30	0.25	5.33	2
TG44	330 - 669.9	133 - 690.0	$D_N - 21.0$	8.10	1.80	0.40	0.35	0.30	7.00	2
TG45	670 - 999.9	-	$D_N - 28.0$	9.50	2.50	0.45	0.40	0.35	8.40	2
TG45X	1,000 - 2,700	-	$D_N - 28.0$	9.50	2.50	0.45	0.40	0.35	8.40	2

* At pressures > 30 MPa: Use diameter tolerance H8/f8 (bore / shaft) in area of seal.

At pressures > 10 MPa it is recommendable to choose the next larger cross section according to the column "Available range" i.e. for shaft $\emptyset D_N = 80$ mm: TG43 00 800-

ORDERING EXAMPLE

Roto Glyd Ring®, complete with O-Ring, standard application:

Series:	TG42 from Table 76
Boe diameter:	$D_N = 80.0$ mm
Dimensions:	TG4200800 from Table 77

Select the material from Table 73. The corresponding code numbers are appended to the TSS Part No. Together they form the TSS Article No. The TSS Article No. for all intermediate sizes not shown in Table 77 can be determined following the example opposite.

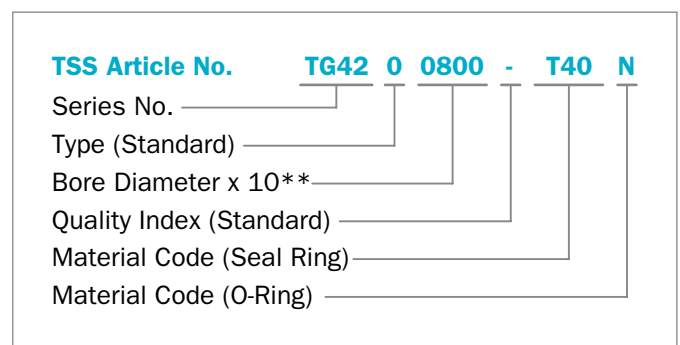

** For diameters $\geq 1,000.0$ mm multiply only by factor 1.

Example: TG35X for diameter 1,200.0 mm

TSS Article No.: TG45X1200 – T40N



Table 77: Standard Installation Dimensions / TSS Part Number

Bore Dia.	Groove Dia.	Groove Width	TSS Part No.	O-Ring Dimensions	Bore Dia.	Groove Dia.	Groove Width	TSS Part No.	O-Ring Dimensions
D_N f8/h9	d_1 H9	L_1 +0.2			D_N f8/h9	d_1 H9	L_1 +0.2		
10.0	5.1	2.2	TG4000100	4.80 x 1.80	220.0	204.5	6.3	TG4302200	202.57 x 5.33
12.0	7.1	2.2	TG4000120	6.70 x 1.80	230.0	214.5	6.3	TG4302300	208.92 x 5.33
14.0	9.1	2.2	TG4000140	8.75 x 1.80	240.0	224.5	6.3	TG4302400	221.62 x 5.33
15.0	10.1	2.2	TG4000150	9.50 x 1.80	250.0	234.5	6.3	TG4302500	234.32 x 5.33
16.0	11.1	2.2	TG4000160	10.60 x 1.80	280.0	264.5	6.3	TG4302800	266.07 x 5.33
18.0	13.1	2.2	TG4000180	12.42 x 1.78	300.0	284.5	6.3	TG4303000	278.77 x 5.33
20.0	15.1	2.2	TG4000200	14.00 x 1.78	320.0	304.5	6.3	TG430320	304.17 x 5.33
23.0	18.1	2.2	TG4000230	17.17 x 1.78	350.0	329.0	8.1	TG4403500	329.57 x 7.00
25.0	20.1	2.2	TG4000250	19.00 x 1.80	380.0	359.0	8.1	TG4403800	354.97 x 7.00
28.0	20.5	3.2	TG4100280	20.29 x 2.62	400.0	379.0	8.1	TG4404000	367.67 x 7.00
30.0	25.1	2.2	TG4000300	25.12 x 1.78	420.0	399.0	8.1	TG4404200	393.07 x 7.00
32.0	27.1	2.2	TG4000320	26.70 x 1.78	450.0	429.0	8.1	TG4404500	417.96 x 7.00
35.0	30.1	2.2	TG4000350	29.87 x 1.78	480.0	459.0	8.1	TG4404800	456.06 x 7.00
40.0	32.5	3.2	TG4100400	31.42 x 2.62	500.0	479.0	8.1	TG4405000	468.76 x 7.00
45.0	37.5	3.2	TG4100450	36.17 x 2.62	600.0	579.0	8.1	TG4406000	582.68 x 7.00
50.0	42.5	3.2	TG4100500	40.94 x 2.62	700.0	672.0	9.5	TG4507000	670.30 x 8.40
54.0	46.5	3.2	TG4100540	45.69 x 2.62	800.0	772.0	9.5	TG4508000	770.30 x 8.40
55.0	47.5	3.2	TG4100550	45.69 x 2.62	900.0	872.0	9.5	TG4509000	870.30 x 8.40
60.0	52.5	3.2	TG4100600	52.07 x 2.62	1,000.0	972.0	9.5	TG45X1000	970.30 x 8.40
63.0	55.5	3.2	TG4100630	53.64 x 2.62	1,500.0	1,472.0	9.5	TG45X1500	1,470.30 x 8.40
65.0	57.5	3.2	TG4100650	56.82 x 2.62	2,000.0	1,972.0	9.5	TG45X2000	1,970.30 x 8.40
70.0	62.5	3.2	TG4100700	61.60 x 2.62	2,500.0	2,472.0	9.5	TG45X2500	2,470.30 x 8.40
75.0	67.5	3.2	TG4100750	66.34 x 2.62					
80.0	69.0	4.2	TG4200800	66.27 x 3.53					
85.0	72.0	4.2	TG4200850	72.62 x 3.53					
90.0	79.0	4.2	TG4200900	78.97 x 3.53					
95.0	84.0	4.2	TG4200950	82.14 x 3.53					
100.0	89.0	4.2	TG4201000	88.49 x 3.53					
110.0	99.0	4.2	TG4201100	98.02 x 3.53					
120.0	109.0	4.2	TG4201200	107.54 x 3.53					
125.0	114.0	4.2	TG4201250	113.89 x 3.53					
130.0	119.0	4.2	TG4201300	117.07 x 3.53					
140.0	124.5	6.3	TG4301400	123.19 x 5.33					
150.0	134.5	6.3	TG4301500	132.72 x 5.33					
150.0	134.5	6.3	TG4301500	132.72 x 5.33					
160.0	144.5	6.3	TG4301600	142.24 x 5.33					
170.0	154.5	6.3	TG4301700	151.77 x 5.33					
180.0	164.5	6.3	TG4301800	164.47 x 5.33					
190.0	174.5	6.3	TG4301900	170.82 x 5.33					
200.0	184.5	6.3	TG4302000	183.52 x 5.33					
210.0	194.5	6.3	TG4302100	189.87 x 5.33					

The bore diameters in **bold** type correspond to the recommendations of ISO 3320.

Other dimensions and all intermediate sizes up to 2,700 mm diameter including imperial (inch) sizes can be supplied.



Turcon[®] Roto Glyd Ring[®] K

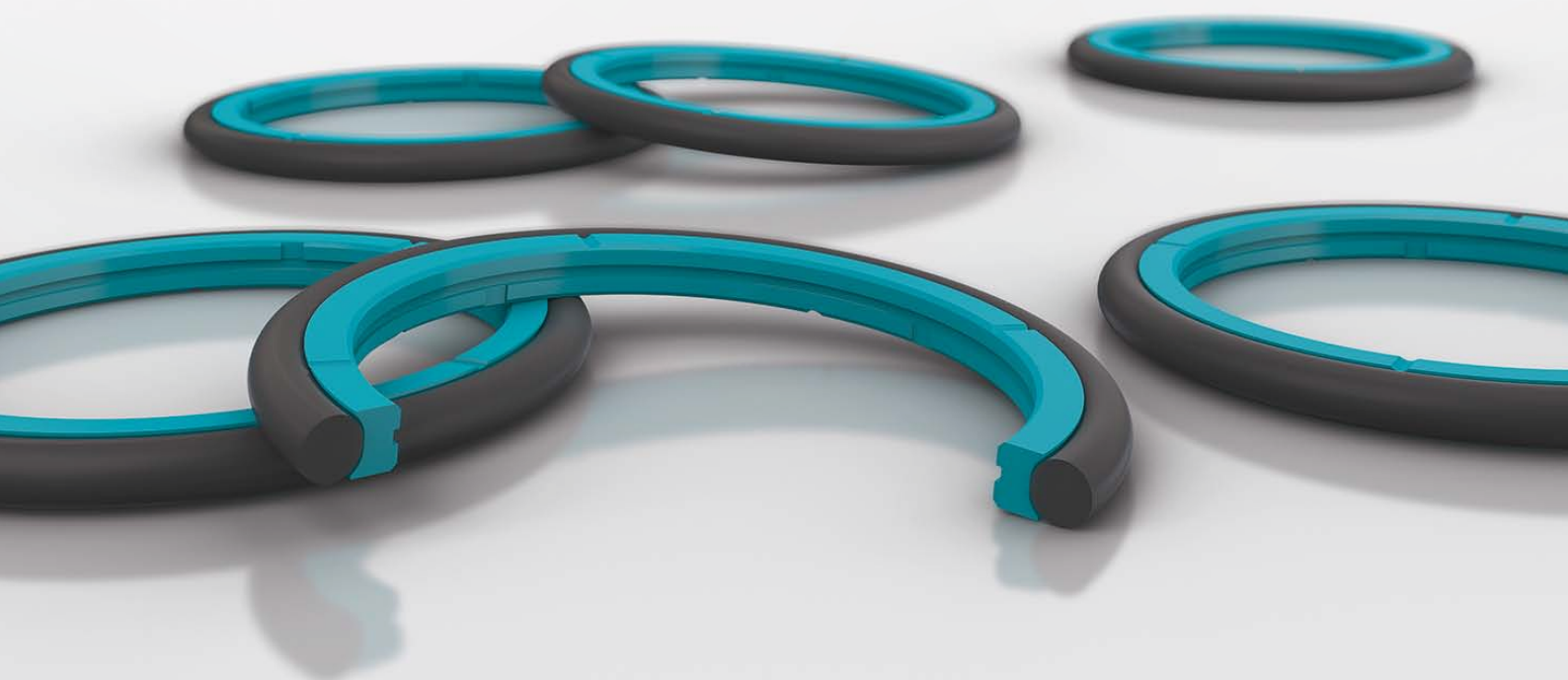





■ Turcon® Roto Glyd Ring® K

■ General Description

Turcon® Roto Glyd Ring® K is used to seal shafts, axles, bores, rotary manifolds and swivels with rotary, helical or oscillating movement. It consists of a seal ring in high-grade Turcon® material activated by an elastomer O-Ring.

The contact surface profile of the seal ring is specially designed for use at high pressure and low sliding speeds.

Preferably the Roto Glyd Ring® K version is used as single acting seal because of its asymmetric appearance although "a semi double-acting" sealing function is maintained

Roto Glyd Ring® K is supplied with axial pressure relief groove. As illustrated in Figure 122 the continuous radial groove is on one side linked to the pressure chamber.

The seal is thus relieved of pressure from one side and can be used for higher pv values than Turcon® Roto Glyd Ring® .

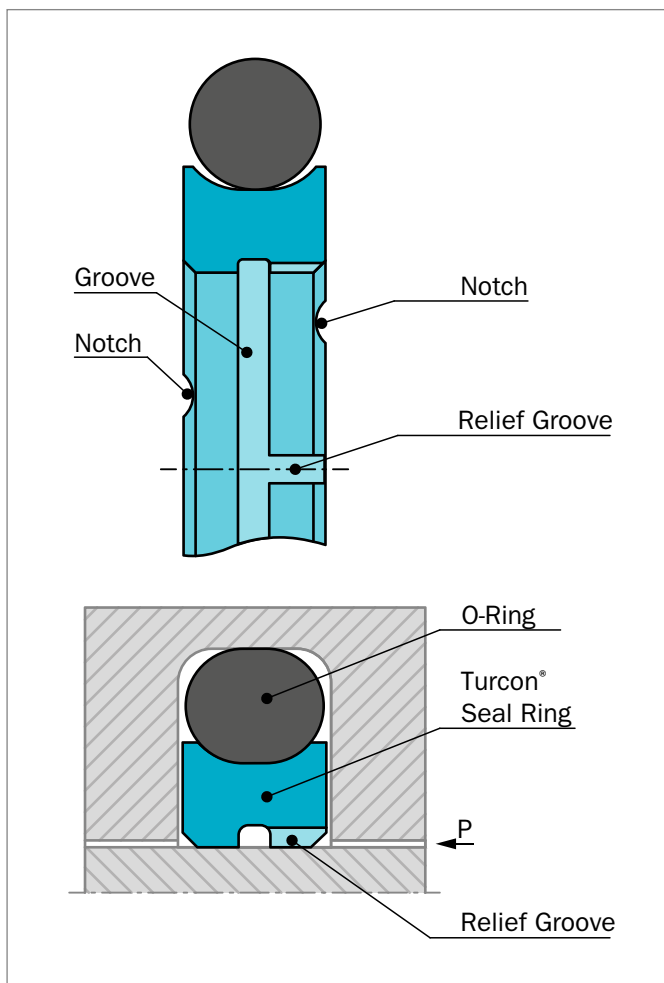

Figure 122: Turcon® Roto Glyd Ring® K with pressure relief.

This Roto Glyd Ring® version is identified in the TSS Article Number by a "K" at the 5th digit see: Ordering Examples. For this seal the direction of installation must be observed.

METHOD OF OPERATION

Initial contact pressure of the Roto Glyd Ring® K is provided by radial compression of the O-Ring. When the system pressure is increased the O-Ring transforms this into additional contact pressure, the contact pressure of the seal is thereby automatically adjusted so sealing is ensured under all service conditions.

The single acting performance of the seal follows from the asymmetrical cross section which allows the seal to respond to high pressure in one direction.

The axial pressure relief groove connecting the pressurized fluid to the circumferential center groove ensures a pressure balance of more than half of the seal contact area. This significantly reduces the seal friction by compared to the double acting Roto Glyd Ring® .

As the K version still has full sealing contact and hold pressure from both directions it can act as a double acting rotary seal. The relieved side must be installed on the side with the higher pressure.

The unrelieved side of the seal is only for low pressure, which should not exceed 3 MPa as it is not sufficiently supported to prevent extrusion from high pressure.

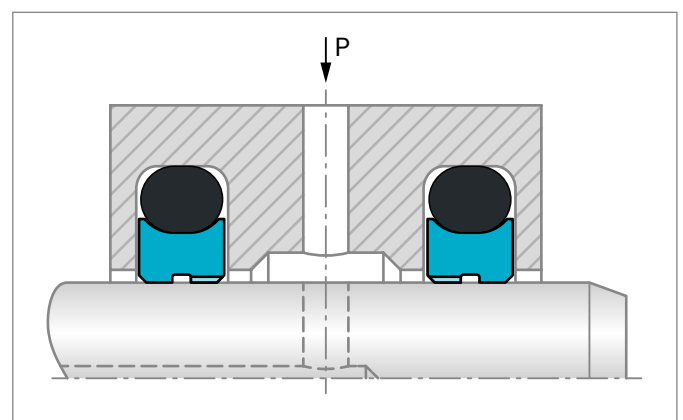

Figure 123: Right installation of Roto Glyd Ring® K

NOTCH

To assure rapid activation of the seal at sudden changes of pressure and direction of motion, radial notches are added on both sides of the seal ring.



ADVANTAGES

- Single acting rotary seal
- Simple groove design
- Small groove dimensions
- Very low friction
- Stick-slip free operation
- No vulcanizing to mating surfaces

TYPICAL APPLICATIONS

Roto Glyd Ring® K is preferably used as a single-acting rotary seal for hydraulic and pneumatic equipment in sectors such as:

- In end caps of rotary distributors and unions
- High pressure valve stems
- Manipulators
- Hydraulic motors
- Pivoting motors in mobile hydraulic and machine tools
- Blow molding machines

OPERATING CONDITIONS

Seal performance is influenced by such factors as lubrication capability of the sealed medium and heat dissipation in the hardware. It follows that testing should always be made.

With good lubrication, the following values can be assumed:

Pressure:	Up to 30 MPa (from pressure relieved side) Up to 3 MPa (from pressure unrelieved side)
Speed:	Up to 0.2 m/s
PV:	Up to 2.5 MPa m/s The value must be reduced for diameters < 50 mm.
Temperatures:	-45 °C to +200 °C *) depending on O-Ring elastomer and medium
Media:	Mineral oil-based hydraulic fluids, flame-retardant hydraulic fluids, environmentally friendly hydraulic fluids (bio-oils), water and others, depending on seal and elastomer material..

IMPORTANT NOTE

The above data are maximum values and cannot be used at the same time, e. g. the maximum operating speed depends on material type, pressure, temperature and gap value. Temperature range also depends on media.

*) IMPORTANT NOTE

In the case of unpressurized applications in temperatures below 0 °C please contact your local Trelleborg Sealing Solutions marketing company for more information.

FRICIONAL POWER

Guide values for the frictional power P can be determined from the graph in Figure 124. They are shown as a function of the sliding speed and operating pressure for a shaft diameter of 50 mm with an oil temperature of 60 °C. At higher temperatures, these application limits must be reduced.

Formula for other diameters d:

$$P = \frac{P_{50} \times (d)}{(50 \text{ mm})} \text{ [W]}$$

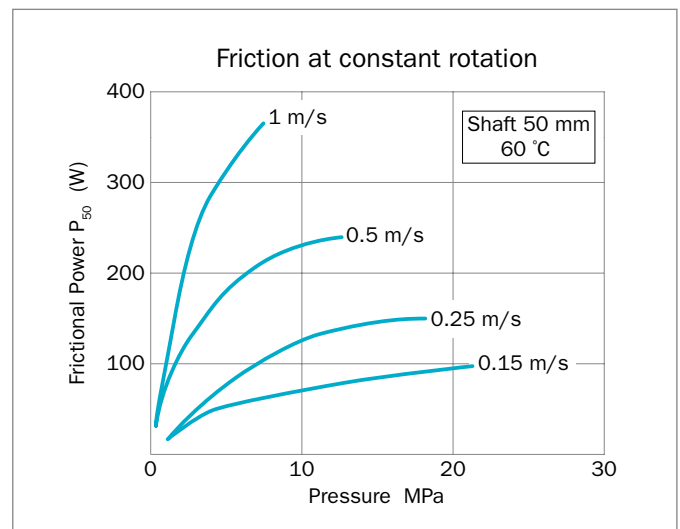

Figure 124: Frictional power for Turcon® Roto Glyd Ring® K

The guide values apply for constant operating conditions. Changes in operating conditions such as pressure fluctuations or alternating directions of shaft rotation can result in considerably higher friction values.



INSTALLATION INSTRUCTIONS

Roto Glyd Ring® is installed according to information at page 309.

Closed groove installation according to dimensions at Table 79 on page 242.

RECOMMENDED MATERIALS

The following material combinations have proven effective for rotary applications:

Turcon® Roto Glyd Ring® K in Turcon® T40

All-round material in lubricating fluids and fluids with limited lubrication e. g. water:

O-Ring:	NBR 70 Shore A	N
	FKM 70 Shore A	V
	HNBR 70 Shore A	H
	(according to temperature)	

Set code: T40N, T40V or T40H

Turcon® Roto Glyd Ring® K in Turcon® M15

Material with high sealing effect for light to medium applications in fluids with good lubrication:

O-Ring:	NBR 70 Shore A	N
	FKM 70 Shore A	V
	HNBR 70 Shore A	H
	(according to temperature)	

Set code: M15N, M15V or M15H

Turcon® Roto Glyd Ring® K in Zurcon® Z80

For slow turning applications with fluid, air, gases and risk of high abrasive wear; temperature limit -45 °C to +80 °C:

O-Ring	NBR 70 Shore A
--------	----------------

Set code: Z80N

Z80 are for slow turning motion and not for constant rotation.

For specific applications other Turcon® and Zurcon® materials are available.



Table 78: Turcon® Materials

Material, Applications, Properties	Code	O-Ring Material Shore A	Code	O-Ring Operating Temp.* °C	Mating Surface Material	MPa max. Dynamic
Turcon® M12 For lubricated applications High compressive strength Low friction Tight surface texture High sealing effect Good sliding properties Good extrusion resistance Mineral filled Color: Dark green-gray	M12	NBR 70	N	-30 to +100	Steel hardend	15
		NBR 70 Low temp.	T	-45 to +80	Steel, chrome plated (shaft) Cast iron	
		FKM 70	V	-10 to +200		
		HNBR 70	H	-30 to +150		
Turcon® M15 For lubricating fluids and fluids with low lubricating properties Excellent for rotary service High sealing effect Very good wear properties Low friction Polyaramid, mineral fiber, lubricant and graphite filled Color: Dark gray	M15	NBR 70	N	-30 to +100	Steel hardend	25
		NBR 70 Low temp.	T	-45 to +80	Steel chrome plated (shaft) Cast iron	
		FKM 70	V	-10 to +200		
		HNBR 70	H	-30 to +150		
Turcon® T10 Hydraulics and pneumatics for lubricating and non-lubricating fluids High extrusion resistance Good chemical resistance BAM tested Carbon graphite filled Color: Black	T10	NBR 70	N	-30 to +100	Steel hardend	15
		NBR 70 Low temp.	T	-45 to +80	Steel, chrome plated Cast iron	
		FKM 70	V	-10 to +200		
		HNBR 70	H	-30 to +150		
Turcon® M40 All round material for rotary and turning movements For lubricating fluids and fluids with low lubricating properties, e.g. water Surface texture not suitable for gases Carbon fiber filled Color: Gray	T40	NBR 70	N	-30 to +100	Steel	30
		NBR 70 Low temp.	T	-45 to +80	Steel chrome plated Cast iron	
		FKM 70	V	-10 to +200	Stainles steel	
		HNBR 70	H	-30 to +150	Hard Alloys	

Table is continued on next page



Material, Applications, Properties	Code	O-Ring Material Shore A	Code	O-Ring Operating Temp.* °C	Mating Surface Material	MPa max. Dynamic
Zurcon® Z80 For lubricating fluids and fluids with low lubricating properties, water, air and gasses at low pressure Good abrasion resistance Good chemical resistance Not for constant rotation Max. working temperature +80 °C Ultra high molecular weight polyethylene Color: White to off-white	Z80	NBR 70	N	-30 to +100	Steel	20
		NBR 70 Low temp.	T	-45 to +80	Steel chrome plated Cast iron	
		FKM 70	V	-10 to +200	Stainles steel Hard Alloys	

* The O-Ring operation temperature is only valid in mineral hydraulic oil.

BAM: Approved by "Bundesanstalt Materialprüfung, Germany".

Highlighted materials are recommended.



■ Installation Recommendation for Shaft

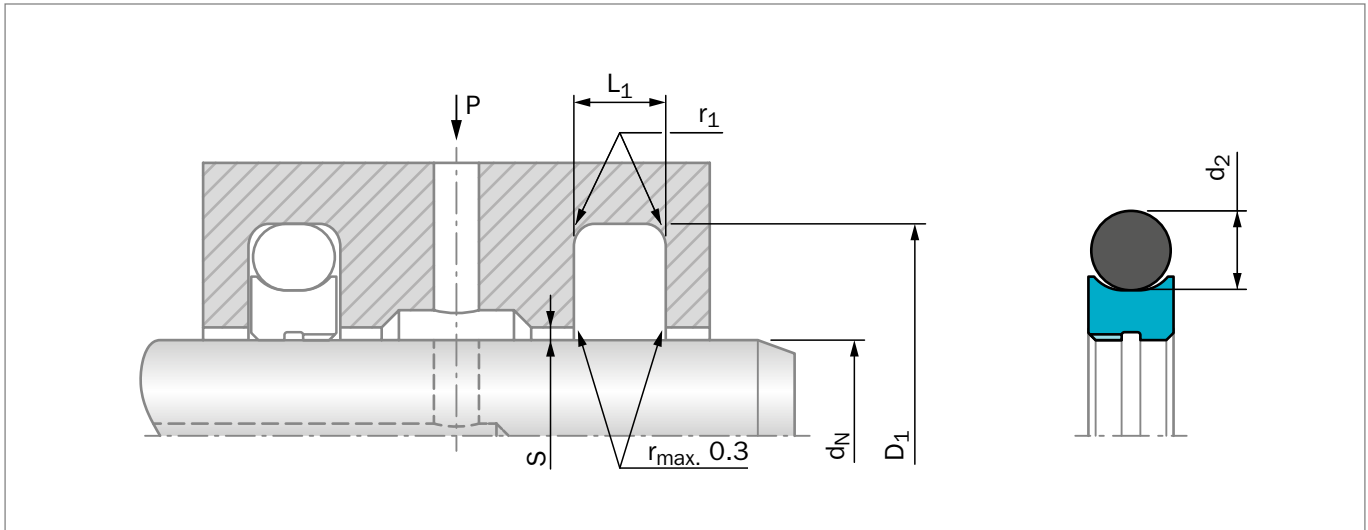

Figure 125: Installation Drawing

Table 79: Installation Dimensions – Standard Recommendations

Series Number	Shaft Diameter d_N f8/h9		Groove Diameter D_1 H9	Groove Width L_1 +0.2	Radius r_1	Radial Clearance S_{max}^*			O-Ring Cross-Section- \emptyset d_2	No. of Grooves in the Sealing Surface
	Recommended Range	Available Range				10 MPa	20 MPa	30 MPa		
TG31K	19 - 37.9	10 - 245.0	$d_N + 7.5$	3.20	0.60	0.20	0.15	0.10	2.62	1
TG32K	38 - 199.9	19 - 455.0	$d_N + 11.0$	4.20	1.00	0.25	0.20	0.15	3.53	1
TG33K	200 - 255.9	38 - 655.0	$d_N + 15.5$	6.30	1.30	0.30	0.25	0.20	5.33	2
TG34K	256 - 649.9	120 - 655.0	$d_N + 21.0$	8.10	1.80	0.35	0.30	0.25	7.00	2
TG35K	650 - 999.9	650 - 999.9	$d_N + 28.0$	9.50	2.50	0.40	0.35	0.30	8.40	2

* At pressures > 30 MPa: Use diameter tolerance H8/f8 (bore / shaft) in area of seal.

At pressures > 10 MPa it is recommendable to choose the next larger cross section according to the column "Available range" i.e. for shaft $\emptyset d_N = 80$ mm: TG33K 800-.

ORDERING EXAMPLE

Turcon® Roto Glyd Ring® K, complete with O-Ring, standard application:

Series:	TG32K (from Table 79)
Shaft diameter:	$d_N = 80$ mm
TSS Part No.:	TG32K0800 (from Table 80)

Select the material from Table 78. The corresponding code numbers are appended to the TSS Part No. Together they form the TSS Article No. The TSS Article No. for all intermediate sizes not shown in Table 80 can be determined following the example opposite.

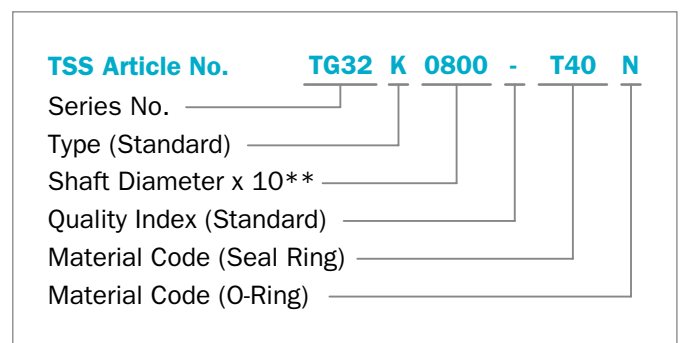

** For diameters $d_N \geq 1,000.0$ mm only on TSS Special Article Number.



Table 80: Standard Installation Dimensions / TSS Part Number

Shaft Dia.	Groove Dia.	Groove Width	TSS Part No.	O-Ring Dimensions	Shaft Dia.	Groove Dia.	Groove Width	TSS Part No.	O-Ring Dimensions
d_N f8/h9	D_1 H9	L_1 +0.20			d_N f8/h9	D_1 H9	L_1 +0.20		
20.0	27.5	3.2	TG31K0200	21.89 x 2.62	210.0	225.5	6.3	TG33K2100	215.27 x 5.33
22.0	29.5	3.2	TG31K0220	25.07 x 2.62	220.0	235.5	6.3	TG33K2200	227.97 x 5.33
25.0	32.5	3.2	TG31K0250	28.24 x 2.62	230.0	245.5	6.3	TG33K2300	234.32 x 5.33
28.0	35.5	3.2	TG31K0280	31.42 x 2.62	240.0	255.5	6.3	TG33K2400	247.02 x 5.33
30.0	37.5	3.2	TG31K0300	32.99 x 2.62	250.0	265.5	6.3	TG33K2500	253.37 x 5.33
32.0	39.5	3.2	TG31K0320	34.59 x 2.62	280.0	301.0	8.1	TG34K2800	291.47 x 7.00
35.0	42.5	3.2	TG31K0350	37.77 x 2.62	300.0	321.0	8.1	TG34K3000	304.17 x 7.00
36.0	43.5	3.2	TG31K0360	39.34 x 2.62	320.0	341.0	8.1	TG34K3200	329.57 x 7.00
40.0	51.0	4.2	TG32K0400	44.04 x 3.53	350.0	371.0	8.1	TG34K3500	354.97 x 7.00
42.0	53.0	4.2	TG32K0420	47.22 x 3.53	360.0	381.0	8.1	TG34K3600	367.67 x 7.00
45.0	56.0	4.2	TG32K0450	50.39 x 3.53	400.0	421.0	8.1	TG34K4000	405.26 x 7.00
48.0	59.0	4.2	TG32K0480	53.57 x 3.53	500.0	521.0	8.1	TG34K5000	506.86 x 7.00
50.0	61.0	4.2	TG32K0500	53.57 x 3.53	550.0	571.0	8.1	TG34K5500	557.66 x 7.00
52.0	63.0	4.2	TG32K0520	56.74 x 3.53	600.0	621.0	8.1	TG34K6000	608.08 x 7.00
55.0	66.0	4.2	TG32K0550	59.92 x 3.53	700.0	728.0	9.5	TG35K7000	712.90 x 8.40*
56.0	67.0	4.2	TG32K0560	59.92 x 3.53	800.0	828.0	9.5	TG35K8000	812.90 x 8.40*
60.0	71.0	4.2	TG32K0600	63.09 x 3.53	900.0	928.0	9.5	TG35K9000	912.90 x 8.40*
63.0	74.0	4.2	TG32K0630	66.27 x 3.53					
65.0	76.0	4.2	TG32K0650	69.44 x 3.53					
70.0	81.0	4.2	TG32K0700	75.79 x 3.53					
75.0	86.0	4.2	TG32K0750	78.97 x 3.53					
80.0	91.0	4.2	TG32K0800	85.32 x 3.53					
85.0	96.0	4.2	TG32K0850	88.49 x 3.53					
90.0	101.0	4.2	TG32K0900	94.84 x 3.53					
95.0	106.0	4.2	TG32K0950	101.19 x 3.53					
100.0	111.0	4.2	TG32K1000	104.37 x 3.53					
105.0	116.0	4.2	TG32K1050	110.72 x 3.53					
110.0	121.0	4.2	TG32K1100	113.89 x 3.53					
115.0	126.0	4.2	TG32K1150	120.24 x 3.53					
120.0	131.0	4.2	TG32K1200	123.42 x 3.53					
125.0	136.0	4.2	TG32K1250	129.77 x 3.53					
130.0	141.0	4.2	TG32K1300	136.12 x 3.53					
135.0	146.0	4.2	TG32K1350	139.29 x 3.53					
140.0	151.0	4.2	TG32K1400	145.64 x 3.53					
150.0	161.0	4.2	TG32K1500	158.34 x 3.53					
160.0	171.0	4.2	TG32K1600	164.69 x 3.53					
170.0	181.0	4.2	TG32K1700	177.39 x 3.53					
180.0	191.0	4.2	TG32K1800	183.74 x 3.53					
190.0	201.0	4.2	TG32K1900	196.44 x 3.53					
200.0	215.5	6.3	TG33K2000	208.92 x 5.33					

The Shaft diameters in **bold** type correspond to the recommendations of ISO 3320.

Other dimensions and all intermediate sizes up to 999.9 mm diameter including inch sizes can be supplied. For diameters $\geq 1,000.0$ mm only with a TSS Special Article Number.

* Theoretical ideal O-Ring size



■ Installation Recommendation for Bore

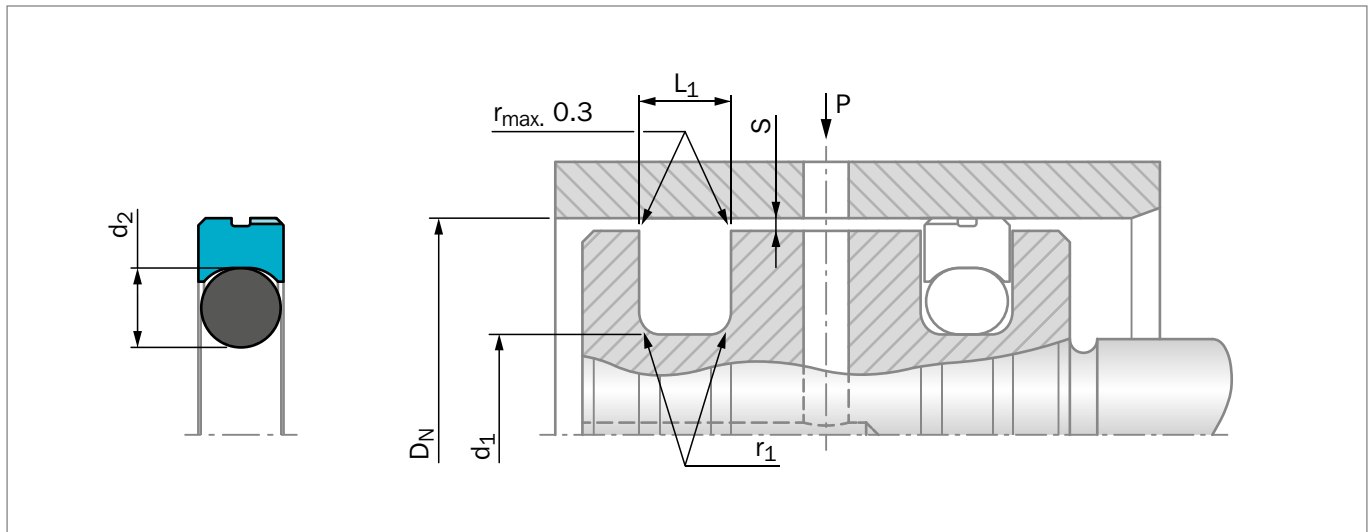

Figure 126: Installation Drawing

Table 81: Installation Dimensions – Standard Recommendations

Series Number	Bore Diameter D_N H9		Groove Diameter d_1 h9	Groove Width $L_1 +0.2$	Radius r_1	Radial Clearance S_{max}^*			O-Ring Cross-Section- \emptyset d_2	No. of Grooves in the Sealing Surface
	Recommended Range	Available Range				10 MPa	20 MPa	30 MPa		
TG41K	40 - 79.9	14 - 250.0	$D_N - 7.5$	3.20	0.60	0.20	0.15	0.10	2.62	1
TG42K	80 - 132.9	22 - 460.0	$D_N - 11.0$	4.20	1.00	0.25	0.20	0.15	3.53	1
TG43K	133 - 329.9	40 - 675.0	$D_N - 15.5$	6.30	1.30	0.30	0.25	0.20	5.33	2
TG44K	330 - 669.9	133 - 690.0	$D_N - 21.0$	8.10	1.80	0.35	0.30	0.25	7.00	2
TG45K	670 - 999.9	-	$D_N - 28.0$	9.50	2.50	0.40	0.35	0.30	8.40	2

* At pressures > 30 MPa: Use diameter tolerance H8/f8 (bore / shaft) in area of seal.

At pressures > 10 MPa it is recommendable to choose the next larger cross section according to the column "Available range" i.e. for shaft \emptyset 80 mm: TG43K 800- .

ORDERING EXAMPLE

Turcon® Roto Glyd Ring® K complete with O-Ring, standard application:

Series:	TG42K (from Table 81)
Bore diameter:	$D_N = 80.0$ mm
TSS Part No.:	TG42K0800 (from Table 82)

Select the material from Table 78. The corresponding code numbers are appended to the TSS Part No. Together they form the TSS Article No. The TSS Article No. for all intermediate sizes not shown in Table 82 can be determined following the example opposite.

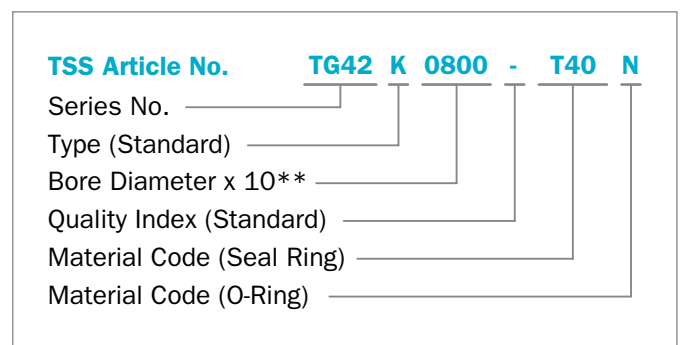

** For diameters $D_N \geq 1,000.0$ mm only with a TSS Special Article Number.



Table 82: Standard Installation Dimensions / TSS Part Number

Bore Dia.	Groove Dia.	Groove Width	TSS Part No.	O-Ring Dimensions	Bore Dia.	Groove Dia.	Groove Width	TSS Part No.	O-Ring Dimensions
D_N f8/h9	d₁ H9	L₁ +0.20			D_N f8/h9	d₁ H9	L₁ +0.20		
40.0	32.5	3.2	TG41K0400	31.42 x 2.62	400.0	379.0	8.1	TG44K4000	367.67 x 7.00
42.0	34.5	3.2	TG41K0420	32.99 x 2.62	420.0	399.0	8.1	TG44K4200	393.07 x 7.00
45.0	37.5	3.2	TG41K0450	36.17 x 2.62	450.0	429.0	8.1	TG44K4500	417.96 x 7.00
48.0	40.5	3.2	TG41K0480	39.34 x 2.62	480.0	459.0	8.1	TG44K4800	456.06 x 7.00
50.0	42.5	3.2	TG41K0500	40.94 x 2.62	500.0	479.0	8.1	TG44K5000	468.76 x 7.00
52.0	44.5	3.2	TG41K0521	44.12 x 2.62	550.0	529.0	8.1	TG44K55000	532.26 x 7.00
55.0	47.5	3.2	TG41K0550	45.69 x 2.62	600.0	579.0	8.1	TG44K6000	582.68 x 7.00
56.0	48.5	3.2	TG41K0560	47.29 x 2.62	650.0	629.0	8.1	TG44K6500	633.48 x 7.00
60.0	52.5	3.2	TG41K0600	52.07 x 2.62	700.0	672.0	9.5	TG45K7000	670.30 x 8.40*
63.0	55.5	3.2	TG41K0630	53.64 x 2.62	800.0	772.0	9.5	TG45K8000	770.30 x 8.40*
65.0	57.5	3.2	TG41K0650	56.82 x 2.62	900.0	872.0	9.5	TG45K9000	870.30 x 8.40*
70.0	62.5	3.2	TG41K0700	61.60 x 2.62					
75.0	67.5	3.2	TG41K0750	66.34 x 2.62					
80.0	69.0	4.2	TG42K0800	66.27 x 3.53					
85.0	74.0	4.2	TG42K0850	72.62 x 3.53					
90.0	79.0	4.2	TG42K0900	78.97 x 3.53					
95.0	84.0	4.2	TG42K0950	82.14 x 3.53					
100.0	89.0	4.2	TG42K1000	88.49 x 3.53					
110.0	99.0	4.2	TG42K1100	98.02 x 3.53					
115.0	104.0	4.2	TG42K1150	101.19 x 3.53					
120.0	109.0	4.2	TG42K1200	107.54 x 3.53					
125.0	114.0	4.2	TG42K1250	113.89 x 3.53					
130.0	119.0	4.2	TG43K1300	117.07 x 5.33					
135.0	119.5	6.3	TG43K1350	116.84 x 5.33					
140.0	124.5	6.3	TG43K1400	123.19 x 5.33					
150.0	134.5	6.3	TG43K1500	132.72 x 5.33					
160.0	144.5	6.3	TG43K1600	142.24 x 5.33					
170.0	154.5	6.3	TG43K1700	151.77 x 5.33					
180.0	164.5	6.3	TG43K1800	164.47 x 5.33					
190.0	174.5	6.3	TG43K1900	170.82 x 5.33					
200.0	184.5	6.3	TG43K2000	183.52 x 5.33					
210.0	194.5	6.3	TG43K2100	189.87 x 5.33					
220.0	204.5	6.3	TG43K2200	202.57 x 5.33					
230.0	214.5	6.3	TG43K2300	208.92 x 5.33					
240.0	224.5	6.3	TG43K2400	221.62 x 5.33					
250.0	234.5	6.3	TG43K2500	234.32 x 5.33					
280.0	264.5	6.3	TG43K2800	266.07 x 5.33					
300.0	284.5	6.3	TG43K3000	278.77 x 5.33					
320.0	304.5	6.3	TG43K3200	304.17 x 5.33					
350.0	334.5	8.1	TG43K3500	329.57 x 7.00					

The Bore diameters in **bold** type correspond to the recommendations of ISO 3320.

Other dimensions and all intermediate sizes up to 999.9 mm diameter including inch sizes can be supplied. For diameters $\geq 1,000.0$ mm only with a TSS Special Article Number.

* Theoretical ideal O-Ring size



Turcon[®] Roto Glyd Ring[®] V







■ Turcon® Roto Glyd Ring® V¹⁾

■ General Description

Turcon® Roto Glyd Ring® V with pressure relief is used to seal rotary applications, such as transmission lead-throughs, journals and swivels, with rotary or oscillating movement.

The seal is double-acting and can be exposed to pressure from one, or both, sides.

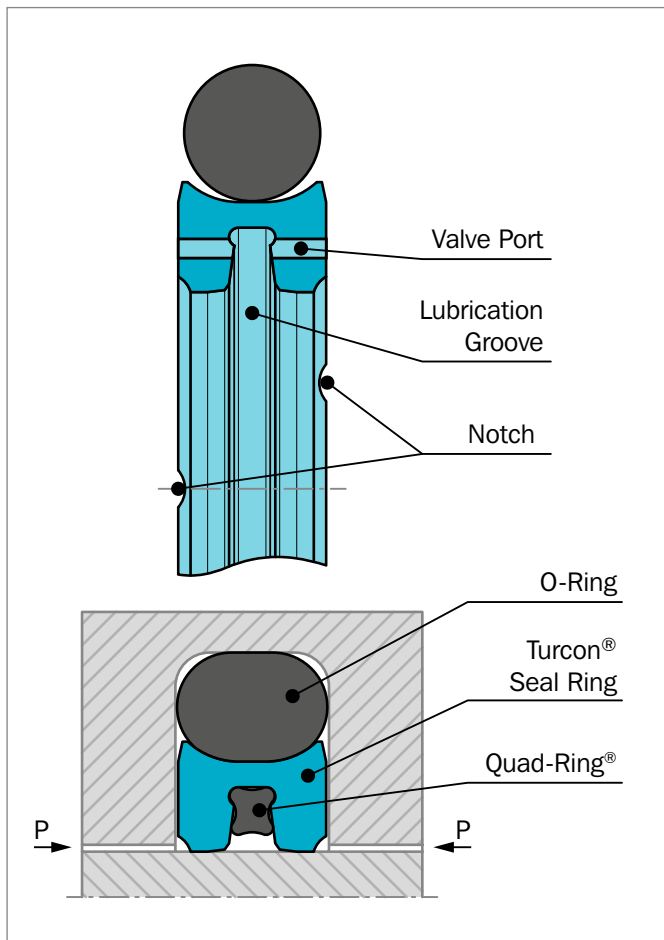

Figure 127 Turcon® Roto Glyd Ring® V with pressure relief

It consists of a seal ring of Turcon® material with an integrated elastomeric Quad-Ring® Seal (X-Ring) and is activated by an O-Ring as an elastic energizing element.

The contact surface profile of the seal ring is specially designed for use under high pressures and sliding speeds of up to 2 m/s.

1) Patent pending: PCT/EP2016/058798

VALVE PORTS

When the system pressure is higher than the pressure in the circumferential lubricating groove, the system pressure bypasses the Quad-Ring® via the valve ports and pressure balances the seal, see Figure 128.

NOTCH

To assure that a rapid activation of the seal takes place at sudden changes of pressure and direction of motion, radial notches are machined on both sides of the seal ring.

METHOD OF OPERATION

The double-acting performance of the seal follows from the symmetrical cross-section, which allows the seal to respond to pressure in both directions.

Initial contact pressure is provided by radial compression of the O-Ring. When the system pressure is activated, the O-Ring transforms this into additional radial seal contact pressure on the mating surface and thereby automatically adjusts the sealing force to ensure high sealing performance under all service conditions.

The Turcon® seal ring profile is supported by two “legs” to reduce contact area with the shaft or bore and thereby decrease friction (torque) and wear.

When exposed to pressure from one side, ports through the sidewalls permit system pressure to deform the Quad-Ring®, which opens to the lubrication groove, see Figure 128. At this point, only one “leg” of Roto Glyd Ring® V is in full pressurized contact with the counter surface and pressure is balanced around half of the dynamic contact area. The other “leg” is just obtaining a minor part of the pressure, which is mainly coming from the initial O-Ring compression – with the result of a major reduction in frictional heat generation.

Reduced contact surfaces under all operating conditions significantly improve friction and wear characteristics.

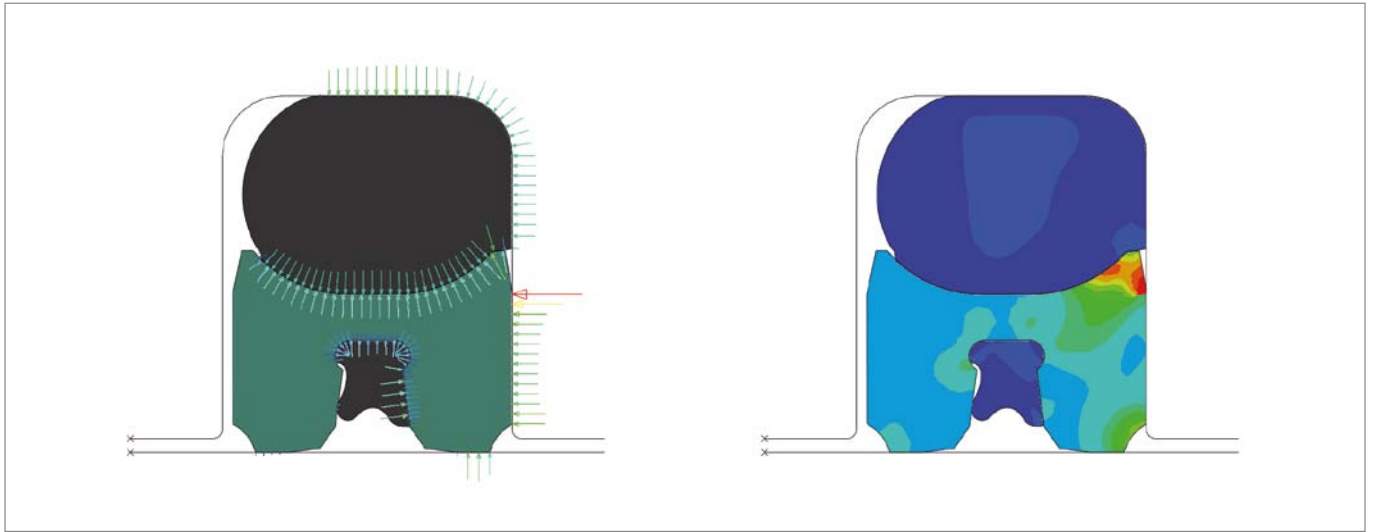

Figure 128 Turcon® Roto Glyd Ring® V - Finite Element Analysis (FEA).

In Figure 128, the system pressure is acting on the left side of the seal and has, via the valve ports, deformed the Quad-Ring® and balanced pressure over half of the dynamic contact area of the seal. The full system pressure is then only interacting on the right leg.

ADVANTAGES

- Available for shaft and bore sealing applications
- Low to high pressure
- Low to medium speed
- Low friction
- Stick-slip-free starting, no sticking
- High abrasion resistance and dimensional stability
- Simple groove design, small groove dimensions
- Recommended Turcon® materials: M15, M30, M04, T40 and Zurcon® Z80 for all shaft sizes from 35 mm and all bore sizes from 22 mm up to diameter 500 mm

TYPICAL APPLICATIONS

Roto Glyd Ring® V is used as a double-acting rotary seal for hydraulic and pneumatic equipment in applications such as:

- Rotary distributors and unions
- Rotary transmission lead-troughs
- Rotary connections with swivel movement, e.g. damping units
- High pressure valve stems
- Manipulators
- Pivoting motors in mobile hydraulics and machine tools
- Hydraulic motors
- Blow molding machines
- Top drives
- Rotary index tables
- Core cutting equipment

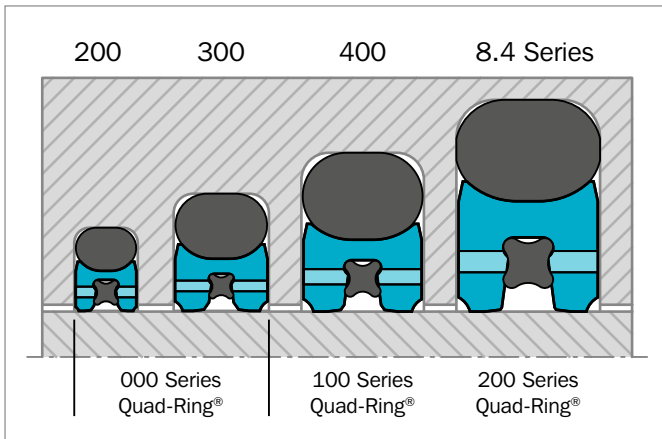

Figure 129 Cross-section profiles of available standard seal series for shaft and bore sealing dependent on Series No.



OPERATING CONDITIONS

Seal performance is influenced by such factors as lubrication capability of the sealed media and heat dissipation in the hardware, it follows that testing should always be made.

With good lubrication, the following values can be assumed as a guideline:

Pressure:	Up to 20 MPa at continuous rotation To 30 MPa at slow turning motion According to temperature and seal material
Temperature:	-45 °C to +130 °C ¹⁾ Dependent on seal ring, O-Ring and Quad-Ring® material
Speed:	Up to 2 m/s According to pressure, temperature and seal material
PV:	Up to 10 MPa m/s The value must be reduced for diameters < 50 mm
Acceleration:	Up to 0.9 m/s ² , in other cases contact your local Trelleborg Sealing Solutions marketing company.
Media:	Mineral oil-based hydraulic fluids, flame-retardant hydraulic fluids, environmentally friendly hydraulic fluids (bio-oils) and others, depending on seal and elastomer material For sealing e.g. coolants, water or air use T40 or Z80

NOTE

For continuous operation at temperatures over +100 °C, pressure and speed must be limited and use of O-Rings / Quad-Ring® in HNBR or FKM

IMPORTANT NOTE

The above data are maximum values and cannot be used at the same time, e.g. the maximum operating speed depends on material type, pressure, temperature and gap value. Temperature range also depends on media.

*) IMPORTANT NOTE FOR THE BORE VERSION:

In case of unpressurized applications in temperatures below 0 °C please contact your local Trelleborg Sealing Solutions marketing company for more information.

MATING SURFACE MATERIALS

Sealing of applications with rotating movements requires very good mating surfaces.

A minimum hardness of 55 HRC to a hardening depth of at least 0.5 mm is recommended - at higher speed and/or pressure 60 to 64 HRC and a depth of 0.5 to 1.0 mm is recommended.

Particular attention must be paid to avoid coatings and plating's, e.g. ceramic surfaces with poor heat dissipation and (hard) chrome where material Turcon® M30 and Zurcon® Z80 are recommended.

FRICTIONAL POWER

Guide values for the frictional power P can be determined from the graph in Figure 130.

They are shown as a function of the sliding speed and operating pressure for a shaft diameter d_N of 50 mm with an oil temperature of +60 °C.

Formula for other diameters d_N :

$$\text{Frictional power } P = \frac{P_{50} \times d_N}{50 \text{ mm}} \text{ [W]}$$

Find P_{50} for Turcon® M15 in the diagram Figure 130

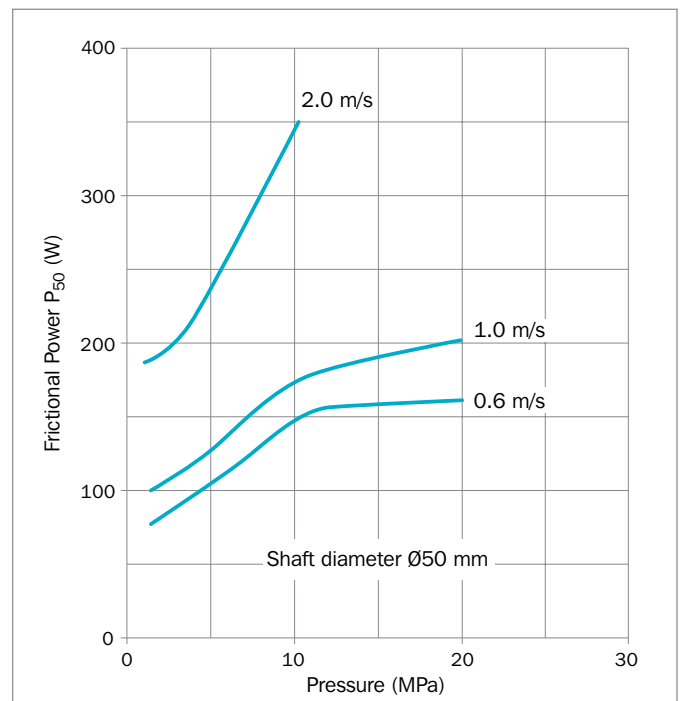

Figure 130 Frictional power for Turcon® Roto Glyd Ring® V in Turcon® M15

The guide values apply for constant operating conditions. Changes in operating condition, such as pressure fluctuations or alternating directions of shaft rotation, can result in considerably higher friction values.



RECOMMENDED MATERIALS

The following material combinations have proven effective for applications with high pressure and medium rotary speed:

Roto Glyd Ring® V in Turcon® M15

Standard material for Roto Glyd Ring® V.

For applications where high sealing efficiency, low friction and good wear resistance are important.

O-Ring: NBR 70 Shore A N
 FKM 70 Shore A V
 (Choice of O-Ring / Quad-Ring®
 depends on media and temperature)

Set code: M15N or M15V

Roto Glyd Ring® V in Turcon® M30

A material that combines high sealing performance, low friction, long service life with good wear and extrusion resistance.

Suitable for hard and softer mating surfaces

O-Ring: NBR 70 Shore A N
 FKM 70 Shore A V
 (Choice of O-Ring / Quad-Ring®
 depends on media and temperature)

Set code: M30N or M30V

Roto Glyd Ring® V in Turcon® M04

An improved carbon-filled material for linear and rotary applications which can run on softer mating surfaces.

O-Ring: NBR 70 Shore A N
 FKM 70 Shore A V
 (Choice of O-Ring / Quad-Ring®
 depends on media and temperature)

Set code: M04N or M04V

Roto Glyd Ring® V in Turcon® T40

Preferred for fluid applications where service life and wear resistance are more important than 100% sealing performance.

For fluids with high and low lubricating properties.

Preferred material for water based fluids

O-Ring: NBR 70 Shore A N
 FKM 70 Shore A V
 (Choice of O-Ring / Quad-Ring®
 depends on media and temperature)

Set code: T40N or T40V

For specific applications, other material combinations are available.

**Table 83: Turcon® and Zurcon® Materials for Roto Glyd Ring® V**

Material, Applications, Properties	Code	O-Ring Material Shore A	Code	O-Ring Operating Temp.* °C1)	Mating Surface Material	MPa max. Dynamic
Turcon® M04 For hydraulics, pneumatics and gases Lubricating and non-lubricating fluids. Good sealing performance Suitable for softer surfaces Carbon filled Color: Black	M04	NBR 70	N	-30 to +100 (130 at low PV)	Steel Steel hardened	20
		NBR 70 Low temp.	T	-45 to +80		
		FKM 70	V	-10 to (+200)		
		HNBR 70	H	-30 to (+150)		
Turcon® M12 For lubricated applications. High compressive strength Low friction Tight surface texture High sealing effect Good sliding properties Good extrusion resistance BAM tested Mineral fiber and additives filled Color: Dark gray	M12	NBR 70	N	-30 to +100 (130 at low PV)	Steel hardened	20
		NBR 70 Low temp.	T	-45 to +80		
		FKM 70	V	-10 to (+200)		
		HNBR 70	H	-30 to (+150)		
Turcon® M15 Standard rotary material For lubricating fluids Excellent for rotary service High sealing effect Very good wear properties Low friction Good extrusion resistance Polyaramid, mineral fiber, lubricant, graphite and Turcon® filled Color: Dark gray	M15	NBR 70	N	-30 to +100 (130 at low PV)	Steel hardened	20
		NBR 70 Low temp.	T	-45 to +80		
		FKM 70	V	-10 to (+200)		
		HNBR 70	H	-30 to (+150)		
Turcon® M30 For lubricating fluids and fluids with low lubricating properties Good wear and extrusion resistance Tight surface structure Good sealing performance Suitable for very hard and softer surfaces Aromatic polymer, graphite, Turcon® filled Color: Dark green-gray	M30	NBR 70	N	-30 to +100 (130 at low PV)	Steel hardened Stainless steel Tungsten carbide HVOF	30
		NBR 70 Low temp.	T	-45 to +80		
		FKM 70	V	-10 to (+200)		
		HNBR 70	H	-30 to (+150)		



Material, Applications, Properties	Code	O-Ring Material Shore A	Code	O-Ring Operating Temp. * °C ¹⁾	Mating Surface Material	MPa max. Dynamic
Turcon® T40 All-round material for rotary and turning movements For lubricating fluids and fluids with low lubricating properties, e.g. water, coolant fluids Long service life in poorly lubricating fluids Surface texture not suitable for gases Carbon fiber filled Color: gray	T40	NBR 70	N	-30 to +100 (130 at low PV)	Steel hardened Hard alloys	20
		NBR 70 Low temp.	T	-45 to +80		
		FKM 70	V	-10 to (+200)		
		HNBR 70	H	-30 to (+150)		
Zurcon® Z80 Only for slow turning movements For lubricating fluids and fluids with low lubricating properties, water, air and gases Good abrasion resistance Good chemical resistance Max. working temperature +80 °C Ultra high molecular weight polyethylene Color: White to off-white	Z80	NBR 70	N	-30 to (+100)	Steel Steel hardened Ceramic coating Tungsten carbide HVOF	30
		NBR 70 Low temp.	T	-45 to +80		

1) The O-Ring Operation Temperature is only valid in mineral hydraulic oil

2) E.g. coolant fluids

Highlighted materials are recommended.

QUAD-RING® MATERIALS

Standard materials for Quad-Ring® :

NBR 70 Shore A: Material code N7004
 FKM 70 Shore A: Material code V7002s

Further special materials on request.

As standard, the Quad-Ring® in NBR elastomer is pre-installed in the circumferential lubrication groove of the Turcon® seal ring – attention must be paid to the medium compatibility and temperature limit of NBR.

If another elastomer material is required, Roto Glyd Ring® V is delivered with the Quad-Ring® uninstalled.

To get Roto Glyd Ring® V **without** Quad-Ring® in NBR, use the feature code [W] in the 5th character in the TSS Article No, See ordering example page 255 or page 258.



■ Recommended Installation for Shaft

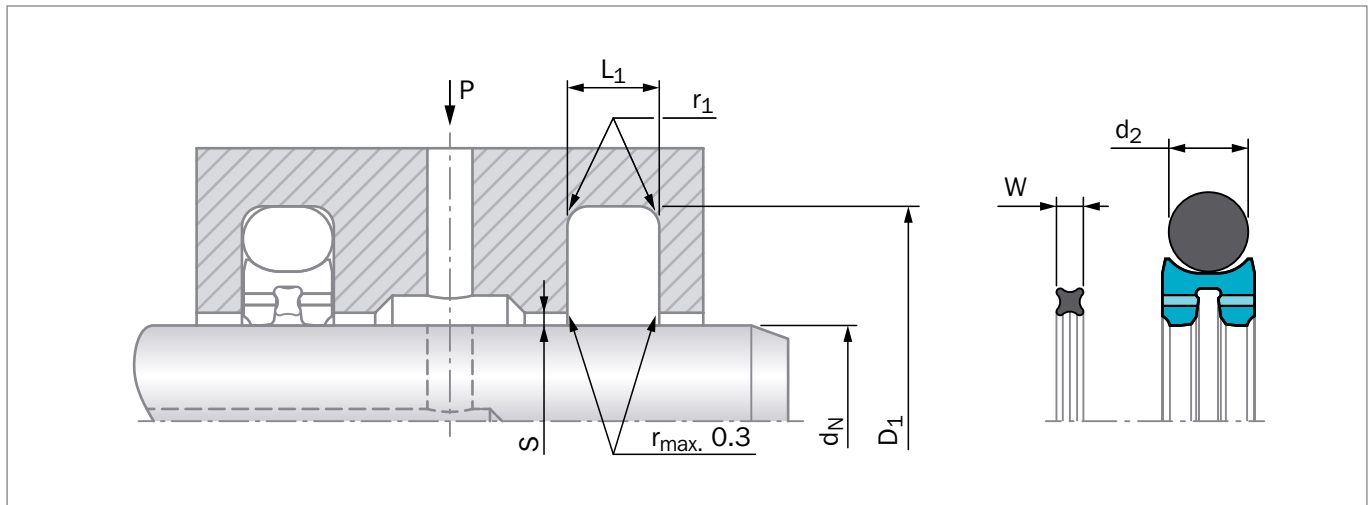

Figure 131 Installation Drawing

Table 84: Installation Dimensions – Standard Recommendations

Series Number	Shaft Diameter d_N f8/h9		Groove Diameter D_1 H9	Groove Width $L_1 +0.2$	Radius r_1	Radial Clearance ¹⁾ S_{max}			O-Ring Cross-Section-Ø d_2	Quad-Ring® Cross-Section-Ø W
	Standard Application	Available Range				10 MPa	20 MPa	30 MPa		
TG720	35 - 79.9	35 - 144.9	$d_N + 11.0$	4.2	1.0	0.40	0.25	0.15	3.53	1.78
TG730	80 - 144.9	38 - 144.9	$d_N + 15.5$	6.3	1.3	0.50	0.30	0.20	5.33	1.78
TG740	145 - 269.9	80 - 269.9	$d_N + 21.0$	8.1	1.8	0.60	0.35	0.25	7.00	2.62
TG750	270 - 500	200 - 500	$d_N + 28.0$	9.5	2.5	0.70	0.40	0.30	8.40	3.53

- 1) At pressures > **30 MPa** use diameter tolerance H8/f8 (bore/rod) in the area of the seal or consult your local Trelleborg Sealing Solutions marketing company for alternative material or profiles.
Slydring® / Wear Rings are not applicable at very small radial clearances, please consult the Slydring® catalog.

ORDERING EXAMPLE

Roto Glyd Ring® V, complete with Quad-Ring® in NBR pre-installed and O-Ring, standard application:

Series: TG730 from Table 84

Shaft diameter: $d_N = 80.0$ mm

TSS Part No.: TG7300800

Select the material from Table 83. The corresponding code numbers are appended to the TSS Part No. (from Table 85). Together these form the TSS Article Number. The TSS Article Number for all intermediate sizes can be determined following the example:

TSS Article No.	TG73	0	0800	-	M15	N
Series No.	_____	_____	_____	_____	_____	_____
Type (Standard)*	_____	_____	_____	_____	_____	_____
Shaft Diameter x 10**	_____	_____	_____	_____	_____	_____
Quality Index (Standard)	_____	_____	_____	_____	_____	_____
Material Code (Seal Ring)	_____	_____	_____	_____	_____	_____
Material Code (O-Ring)	_____	_____	_____	_____	_____	_____

- 2) Ordering Roto Glyd Ring® V **without** NBR Quad-Ring®

please use suffix "W" in the fifth character TG73W00800-

- 3) For diameters $d_N > 500$ mm only on TSS Special Article Number.



Table 85: Standard Installation Dimensions / TSS Part No.

Shaft Diameter	Groove Diameter	Groove Width	TSS Part No.	O-Ring Dimension	Quad-Ring® Dimension
d_N f8/h9	D_1 H9	L_1 +0.2			
35.0	46.0	4.2	TG7200350	40.87 x 3.53	33.05 x 1.78
36.0	47.0	4.2	TG7200360	40.87 x 3.53	34.65 x 1.78
38.0	53.5	6.3	TG7300380	43.82 x 5.33	37.82 x 1.78
40.0	51.0	4.2	TG7200400	44.04 x 3.53	37.82 x 1.78
45.0	56.0	4.2	TG7200450	50.39 x 3.53	44.17 x 1.78
45.0	60.5	6.3	TG7300450	50.17 x 5.33	44.17 x 1.78
50.0	61.0	4.2	TG7200500	53.57 x 3.53	47.35 x 1.78
50.0	65.5	6.3	TG7300500	56.52 x 5.33	47.35 x 1.78
55.0	66.0	4.2	TG7200550	59.92 x 3.53	53.70 x 1.78
56.0	67.0	4.2	TG7200560	59.92 x 3.53	53.70 x 1.78
56.0	71.5	6.3	TG7300560	62.87 x 5.33	53.70 x 1.78
60.0	71.0	4.2	TG7200600	63.09 x 3.53	56.87 x 1.78
60.0	75.5	6.3	TG7300600	66.04 x 5.33	56.87 x 1.78
63.0	74.0	4.2	TG7200630	66.27 x 3.53	60.05 x 1.78
63.0	78.5	6.3	TG7300630	69.22 x 5.33	60.05 x 1.78
70.0	81.0	4.2	TG7200700	75.79 x 3.53	66.40 x 1.78
70.0	85.5	6.3	TG7300700	75.57 x 5.33	66.40 x 1.78
75.0	86.0	4.2	TG7200750	78.97 x 3.53	72.75 x 1.78
80.0	91.0	4.2	TG7200800	85.32 x 3.53	75.92 x 1.78
80.0	95.5	6.3	TG7300800	85.09 x 5.33	75.92 x 1.78
80.0	101.0	8.1	TG7400800	88 x 7.00	75.87 x 2.62
85.0	96.0	4.2	TG7200850	88.49 x 3.53	82.27 x 1.78
85.0	100.5	6.3	TG7300850	91.44 x 5.33	82.27 x 1.78
90.0	101.0	4.2	TG7200900	94.84 x 3.53	88.62 x 1.78
90.0	105.5	6.3	TG7300900	97.79 x 5.33	88.62 x 1.78
95.0	106.0	4.2	TG7200950	101.19 x 3.53	88.62 x 1.78
100.0	111.0	4.2	TG7201000	104.37 x 3.53	94.97 x 1.78
100.0	115.5	6.3	TG7301000	107.32 x 5.33	94.97 x 1.78
105.0	116.0	4.2	TG7201050	110.72 x 3.53	101.32 x 1.78
105.0	120.5	6.3	TG7301050	110.49 x 5.33	101.32 x 1.78
110.0	121.0	4.2	TG7201100	113.89 x 3.53	107.67 x 1.78
110.0	125.5	6.3	TG7301100	116.84 x 5.33	107.67 x 1.78
120.0	135.5	6.3	TG7301200	126.37 x 5.33	114.02 x 1.78
125.0	136.0	4.2	TG7201250	129.77 x 3.53	120.37 x 1.78
125.0	140.5	6.3	TG7301250	129.54 x 5.33	120.37 x 1.78
125.0	146.0	8.1	TG7401250	132.72 x 7.00	120.32 x 2.62
130.0	145.5	6.3	TG7301300	135.89 x 5.33	126.72 x 1.78
135.0	146.0	4.2	TG7201350	139.29 x 3.53	126.72 x 1.78
135.0	150.5	6.3	TG7301350	142.24 x 5.33	126.72 x 1.78
140.0	151.0	4.2	TG7201400	145.64 x 3.53	133.07 x 1.78



Shaft Diameter	Groove Diameter	Groove Width	TSS Part No.	O-Ring Dimension	Quad-Ring® Dimension
d_N f8/h9	D_1 H9	L_1 +0.2			
140.0	155.5	6.3	TG7301400	145.42 x 5.33	133.07 x 1.78
150.0	171.0	8.1	TG7401500	158.12 x 7.00	145.72 x 2.62
160.0	181.0	8.1	TG7401600	170.82 x 7.00	152.07 x 2.62
170.0	191.0	8.1	TG7401700	177.17 x 7.00	164.77 x 2.62
180.0	201.0	8.1	TG7401800	189.87 x 7.00	171.12 x 2.62
190.0	211.0	8.1	TG7401900	196.22 x 7.00	183.82 x 2.62
200.0	221.0	8.1	TG7402000	208.90 x 7.00	190.17 x 2.62
200.0	228.0	9.5	TG7502000	213 x 8.40	190.09 x 3.53
210.0	231.0	8.1	TG7402100	215.27 x 7.00	202.87 x 2.62
220.0	241.0	8.1	TG7402200	227.97 x 7.00	209.22 x 2.62
220.0	248.0	9.5	TG7502200	209 x 8.40	209.14 x 3.53
230.0	251.0	8.1	TG7402300	240.67 x 7.00	221.92 x 2.62
250.0	271.0	8.1	TG7402500	266.07 x 7.00	240.97 x 2.62
250.0	278.0	9.5	TG7502500	241 x 8.40	240.89 x 3.53
260.0	281.0	8.1	TG7402600	266.07 x 7.00	247.32 x 2.62
280.0	308.0	9.5	TG7502800	293 x 8.40	266.29 x 3.53
300.0	328.0	9.5	TG7503000	313 x 8.40	291.69 x 3.53
320.0	348.0	9.5	TG7503200	333 x 8.40	304.39 x 3.53
350.0	378.0	9.5	TG7503500	330 x 8.40	329.79 x 3.53
360.0	388.0	9.5	TG7503600	355 x 8.40	355.19 x 3.53
400.0	428.0	9.5	TG7504000	413 x 8.40	380.59 x 3.53
500.0	528.0	9.5	TG7505000	513 x 8.40	456.06 x 3.53

The shaft diameters in **bold** type correspond to the recommendations of ISO 3320.

Other dimensions and all intermediate sizes up to 500 mm diameter including imperial (inch) sizes can be supplied.



Recommended Installation for Bore

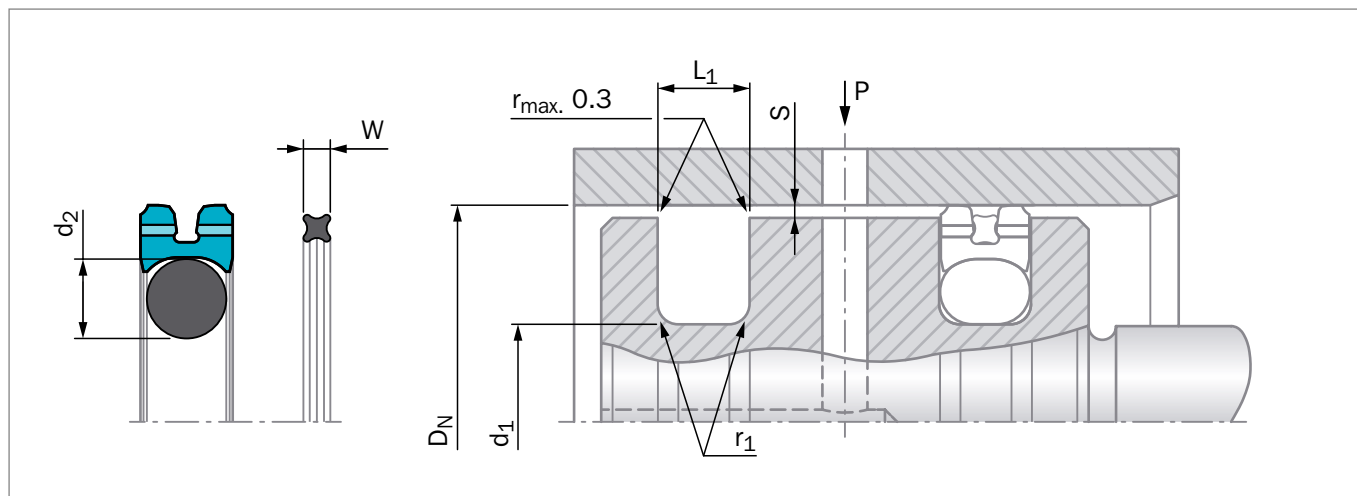

Figure 132 Installation Drawing

Table 86: Installation Dimensions – Standard Recommendations

Series Number	Bore Diameter D_N H9		Groove Diameter d_1 h9	Groove Width $L_1 + 0.2$	Radius r_1	Radial Clearance ¹⁾ S_{max}			O-Ring Cross-Section- \emptyset d_2	Quad-Ring® Cross-Section- \emptyset W
	Standard Application	Available Range				10 MPa	20 MPa	30 MPa		
TG820	22 - 79.9	22 - 149.9	$D_N - 11.0$	4.2	1.00	0.40	0.25	0.15	3.53	1.78
TG830	80 - 149.9	40 - 149.9	$D_N - 15.5$	6.3	1.30	0.50	0.30	0.20	5.33	1.78
TG840	150 - 274.9	85 - 274.9	$D_N - 21.0$	8.1	1.80	0.60	0.35	0.25	7.00	2.62
TG850	275 - 500	200 - 500	$D_N - 28.0$	9.5	2.50	0.70	0.40	0.30	8.40	3.53

1) At pressures > **30 MPa** use diameter tolerance H8/f8 (bore/rod) in the area of the seal or consult your local Trelleborg Sealing Solutions marketing company for alternative material or profiles.
Slydring® / Wear Rings are not applicable at very small radial clearances please consult the Slydring® catalog.

ORDERING EXAMPLE

Roto Glyd Ring® V, complete with Quad-Ring® in NBR pre-installed and O-Ring, standard application:

Series:	TG830 from Table 86
Bore diameter:	$D_N = 80.0$ mm
TSS Part No.:	TG8300800

Select the material from Table 83. The corresponding code numbers are appended to the TSS Part No. (from Table 87) Together these form the TSS Article Number. The TSS Article Number for all intermediate sizes can be determined following the example:

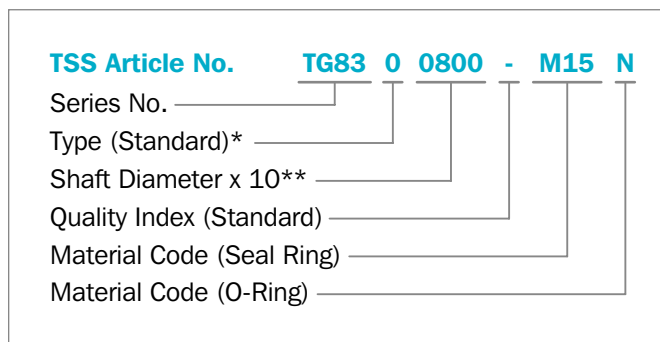

*) Ordering Roto Glyd Ring® V **without** NBR Quad-Ring® please use suffix "W" in the fifth character. TG83**W**00800-

***) For diameters $D_N > 500$ mm only on TSS Special Article Number.



Table 87: Standard Installation Dimensions / TSS Part Number

Bore Diameter	Groove Diameter	Groove Width	TSS Part No.	O-Ring Dimension	Quad-Ring® Dimension
D_N H9	d_1 h9	L_1 +0.2			
22.0	11.0	4.2	TG8200220	10.69 x 3.53	17.17 x 1.78
23.0	12.0	4.2	TG8200230	10.69 x 3.53	17.17 x 1.78
25.0	14.0	4.2	TG8200250	13.87 x 3.53	20.35 x 1.78
28.0	17.0	4.2	TG8200280	15.47 x 3.53	21.95 x 1.78
30.0	19.0	4.2	TG8200300	18.66 x 3.53	25.12 x 1.78
32.0	21.0	4.2	TG8200320	20.22 x 3.53	26.70 x 1.78
35.0	24.0	4.2	TG8200350	23.40 x 3.53	29.87 x 1.78
40.0	29.0	4.2	TG8200400	28.17 x 3.53	34.65 x 1.78
40.0	24.5	6.3	TG8300400	23.16 x 5.33	33.05 x 1.78
45.0	29.5	6.3	TG8300450	27.94 x 5.33	37.82 x 1.78
50.0	39.0	4.2	TG8200500	37.69 x 3.53	44.17 x 1.78
50.0	34.5	6.3	TG8300500	32.69 x 5.33	44.17 x 1.78
54.0	43.0	4.2	TG8200540	40.87 x 3.53	47.35 x 1.78
54.0	38.5	6.3	TG8300540	37.47 x 5.33	47.35 x 1.78
55.0	39.5	6.3	TG8300550	37.47 x 5.33	47.35 x 1.78
60.0	49.0	4.2	TG8200600	47.22 x 3.53	53.70 x 1.78
63.0	52.0	4.2	TG8200630	50.39 x 3.53	56.87 x 1.78
63.0	47.5	6.3	TG8300630	46.99 x 5.33	53.70 x 1.78
65.0	49.5	6.3	TG8300650	46.99 x 5.33	56.87 x 1.78
70.0	59.0	4.2	TG8200700	56.74 x 3.53	63.22 x 1.78
75.0	64.0	4.2	TG8200750	63.09 x 3.53	66.40 x 1.78
75.0	59.5	6.3	TG8300750	56.52 x 5.33	66.40 x 1.78
80.0	69.0	4.2	TG8200800	66.27 x 3.53	72.75 x 1.78
80.0	64.5	6.3	TG8300800	62.87 x 5.33	72.75 x 1.78
83.0	72.0	4.2	TG8200830	69.44 x 3.53	75.92 x 1.78
83.0	67.5	6.3	TG8300830	66.04 x 5.33	72.75 x 1.78
85.0	64.0	8.1	TG8400850	63 x 7.00	72.69 x 2.62
90.0	79.0	4.2	TG8200900	78.97 x 3.53	82.27 x 1.78
90.0	74.5	6.3	TG8300900	72.39 x 5.33	82.27 x 1.78
90.0	69.0	8.1	TG8400900	68 x 7.00	75.87 x 2.62
95.0	84.0	4.2	TG8200950	82.14 x 3.53	88.62 x 1.78
95.0	79.5	6.3	TG8300950	78.74 x 5.33	88.62 x 1.78
100.0	89.0	4.2	TG8201000	88.49 x 3.53	88.62 x 1.78
100.0	84.5	6.3	TG8301000	81.92 x 5.33	88.62 x 1.78
110.0	94.5	6.3	TG8301100	91.44 x 5.33	101.32 x 1.78
120.0	104.5	6.3	TG8301200	100.97 x 5.33	107.67 x 1.78
125.0	114.0	4.2	TG8201250	113.89 x 3.53	114.02 x 1.78
125.0	109.5	6.3	TG8301250	107.32 x 5.33	114.02 x 1.78
125.0	104.0	8.1	TG8401250	103 x 7.00	113.97 x 2.62
130.0	114.5	6.3	TG8301300	113.67 x 5.33	120.37 x 1.78



Bore Diameter	Groove Diameter	Groove Width	TSS Part No.	O-Ring Dimension	Quad-Ring® Dimension
D _N H9	d ₁ h9	L ₁ +0.2			
140.0	124.5	6.3	TG8301400	123.19 x 5.33	126.72 x 1.78
160.0	139.0	8.1	TG8401600	135.89 x 7.00	145.72 x 2.62
170.0	149.0	8.1	TG8401700	145.42 x 7.00	152.07 x 2.62
180.0	159.0	8.1	TG8401800	158.12 x 7.00	164.77 x 2.62
200.0	179.0	8.1	TG8402000	177.17 x 7.00	183.82 x 2.62
200.0	172.0	9.5	TG8502000	171 x 8.40	177.39 x 3.53
210.0	189.0	8.1	TG8402100	183.52 x 7.00	190.17 x 2.62
220.0	199.0	8.1	TG8402200	196.22 x 7.00	202.87 x 2.62
225.0	197.0	9.5	TG8502250	196 x 8.40	202.79 x 3.53
230.0	209.0	8.1	TG8402300	202.57 x 7.00	209.22 x 2.62
240.0	219.0	8.1	TG8402400	215.27 x 7.00	221.92 x 2.62
250.0	229.0	8.1	TG8402500	227.97 x 7.00	228.27 x 2.62
250.0	222.0	9.5	TG8502500	221 x 8.40	228.19 x 3.53
270.0	249.0	8.1	TG8402700	240.67 x 7.00	247.32 x 2.62
270.0	242.0	9.5	TG8502700	241 x 8.40	247.24 x 3.53
280.0	252.0	9.5	TG8502800	251 x 8.40	253.59 x 3.53
300.0	272.0	9.5	TG8503000	271 x 8.40	278.99 x 3.53
320.0	292.0	9.5	TG8503200	291 x 8.40	291.69 x 3.53
350.0	322.0	9.5	TG8503500	321 x 8.40	329.79 x 3.53
380.0	352.0	9.5	TG8503800	351 x 8.40	355.19 x 3.53
400.0	372.0	9.5	TG8504000	371 x 8.40	380.59 x 3.53
420.0	392.0	9.5	TG8504200	391 x 8.40	380.59 x 3.53
450.0	422.0	9.5	TG8504500	421 x 8.40	430.66 x 3.53
480.0	452.0	9.5	TG8504800	451 x 8.40	456.06 x 3.53
500.0	472.0	9.5	TG8505000	471 x 8.40	456.06 x 3.53

The bore diameters printed in **bold** type conform to the recommendations of ISO 3320.

Other dimensions and all intermediate sizes up to 500 mm diameter including imperial (inch) sizes can be supplied.

Zurcon[®] Roto Glyd Ring[®] S







Zurcon® Roto Glyd Ring® S

General Description

Zurcon® Roto Glyd Ring® S is used to seal rotary transmission lead-throughs, journals, swivels etc. with rotary or oscillating movement.

The seal is double-acting and can be exposed to pressure from one, or from both sides.

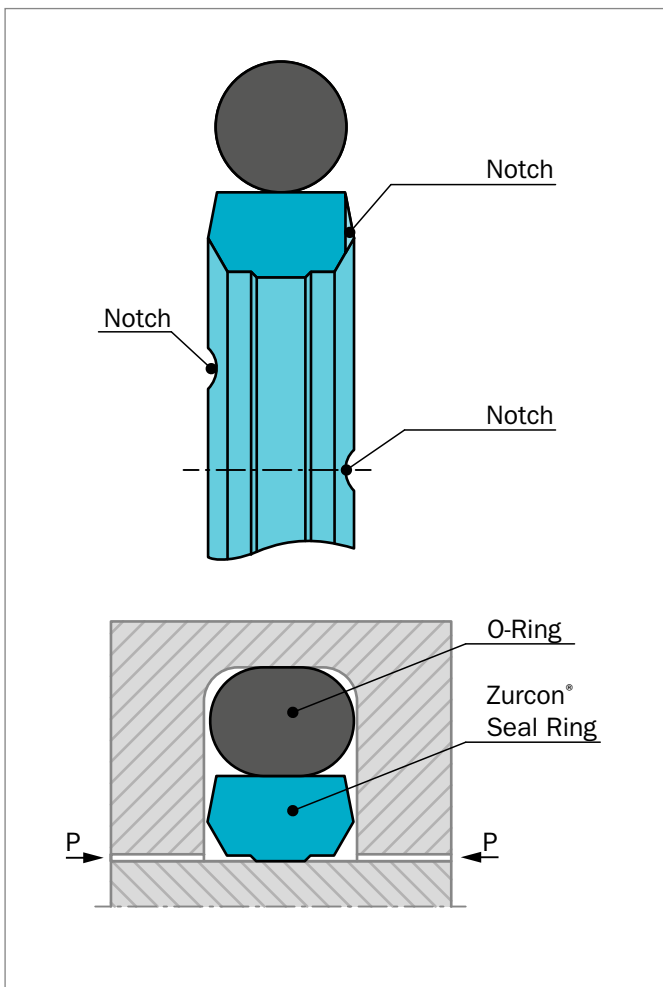

Figure 133 Zurcon® Roto Glyd Ring® S

It consists of a seal ring of Zurcon® material and is activated by an O-Ring as an elastic energizing element.

The contact surface profile of the seal ring is specially designed for use under high pressures and at low sliding speeds.

Pat. pending: DE 101 45914 A1
WO 03/027545 A1

METHOD OF OPERATION

Reduced contact surfaces under all operating conditions significantly improve friction and wear characteristics. When exposed to low pressure, only the central section of the seal comes into contact with the mating surface.

As the system pressure increases, the seal ring is tilted slightly generating the hydrostatic pressure balance in the sealing gap. Tilting the ring under pressure optimizes the lubrication between the seal and the mating surface.

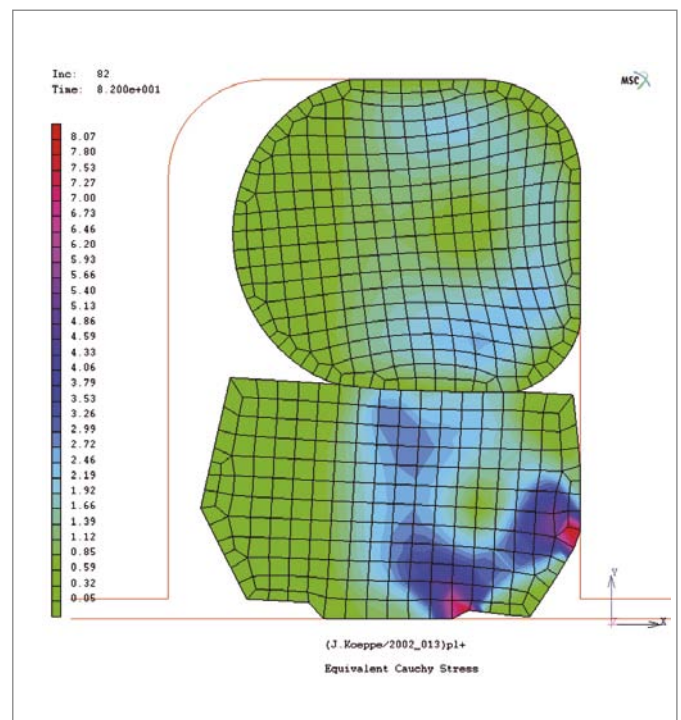

Figure 134 Zurcon® Roto Glyd Ring® S - Finite Element Analysis (FEA)

The profile is supported by a second edge which restricts contact with the shaft or bore, thereby significantly reducing friction and wear. The O-Ring material can be adapted to suit operating conditions. The angle on both sides of Zurcon® Seal Ring prevents extrusion into the system gap.

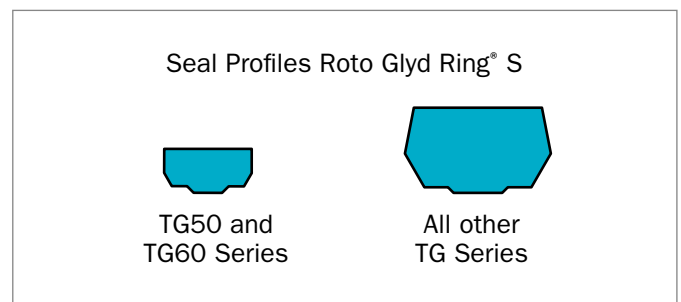

Figure 135 Cross-section profiles depending on Series No.



NOTCH

To assure that a rapid activation of the seal takes place at sudden changes of pressure and direction of motion, radial notches are machined on both sides of the seal ring.

ADVANTAGES

- Available for shaft and bore sealing applications
- Low to high pressure
- Low friction
- Stick-slip-free starting, no sticking
- High abrasion resistance and dimensional stability
- Simple groove design, small groove dimensions
- Available in material Z53 and Z54 for all shaft sizes up to 2,200 mm diameter and for all bore sizes up to 2,300 mm
- Available in material Z80 for all shaft sizes up to 2,600 mm diameter and for all bore sizes up to 2,700 mm.

APPLICATION EXAMPLES

- Shafts, axels and rotary transmission lead-throughs.
- Rotary indexing tables
- Rotary connections with swivel movement, e.g. damping units

OPERATING CONDITIONS

Pressure:	Up to 40 MPa
PV:	Up to 6.5 MPa x m/s
Acceleration:	Up to 0.9 m/s ² , in other cases contact your local Trelleborg Sealing Solutions marketing company.
Temperatures:	-30 °C to +100 °C
Media:	Mineral oil-based hydraulic fluids, flame-retardant hydraulic fluids, environmentally friendly hydraulic fluids (bio-oils) and others, depending on seal and elastomer material. For sealing e.g. coolants, water or air use Z80.

NOTE

For continuous operation at temperatures over +60 °C, pressure and speed must be limited.

Table 88: Material

Material	Pressure P MPa	P x V MPa x m/s	Temperature t° °C
Zurcon® Z53*	40	6.5	-30/+100
Zurcon® Z54	30	6.5	-30/+100
Zurcon® Z80	30	6.5	-30/+80

*Zurcon® Z53 only for p >30MPa

IMPORTANT NOTE

The above data are maximum values and cannot be used at the same time, e. g. the maximum operating speed depends on material type, pressure, temperature and value gap.

INSTALLATION INSTRUCTIONS

Roto Glyd Ring® S is installed according to information at page 309.

Closed groove installation according to dimensions at Table 90 on page 266.

RECOMMENDED MATERIALS

The following material combinations have proven effective for applications with slow turning movements:

Roto Glyd Ring® S in Zurcon® Z80

All round material:

O-Ring:	NBR 70 Shore A	N
	FKM 70 Shore A	V
	(according to media)	

Set code: Z80N or Z80V

Roto Glyd Ring® S in Zurcon® Z54

Material for high sealing effect:

O-Ring:	NBR 70 Shore A	N
---------	----------------	---

Set code: Z54N

For specific applications, other material combinations are available.

**Table 89: Zurcon® Materials for Roto Glyd Ring® S**

Material, Applications, Properties	Code	O-Ring Material Shore A	Code	O-Ring Operating Temp.* °C	Mating Surface Material	MPa max. Dynamic
Zurcon® Z53** For lubricating hydraulic fluids Slowly turning movements Not for constant rotation Very high abrasion and extrusion resistance For counter surface with rougher surface finish Hard to install Limited chemical resistance Max. working temperature +110 °C Cast polyurethane Color: Yellow to light-brown	Z53	NBR 70	N	-30 to +100	Steel hardend	40
		NBR 70 Low temp.	T	-45 to +80	Steel, chrome plated (shaft) Cast iron Ceramic coating Stainless steel	
Zurcon® Z54** For lubricating fluids Slowly turning movements Not for constant rotation Good abrasion resistance Max. working temperature +110 °C Cast polyurethane Color: Turquoise	Z54	NBR 70	N	-30 to +100	Steel	25
		NBR 70 Low temp.	T	-45 to +80	Steel hardend Steel chrome plated (shaft) Ceramic coating Stainless steel	
Zurcon® Z80 For lubricating fluids For limited lubricating fluids***, water, air and gases at low pressure Good abrasion resistance Good chemical resistance Not for constant rotation Max. working temperature +80 °C Ultra high molecular weight polyethylene Color: White to off-white	Z80	NBR 70	N	-30 to +100	Steel	30
		NBR 70 Low temp.	T	-45 to +80	Steel hardend Steel chrome plated (shaft)	
		FKM 70	V	-10 to +80	Ceramic coating Stainless steel	

* The O-Ring operation temperature is only valid in mineral hydraulic oil.

** max. \varnothing 2,200 mm

*** E.g. coolant fluids

BAM: Approved by "Bundesanstalt Materialprüfung, Germany".

Highlighted materials are recommended.



■ Installation Recommendation for Shaft

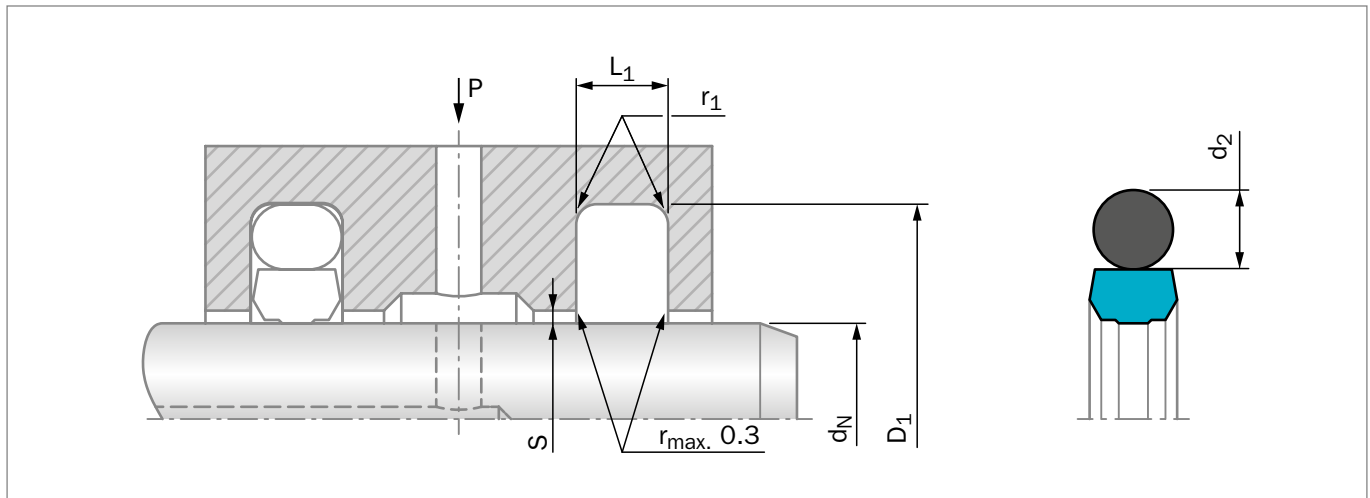

Figure 136 Installation Drawing

Table 90: Installation Dimensions – Standard Recommendations

Series Number	Shaft Diameter d_N f8/h9		Groove Diameter*	Groove Width	Radius	Radial Clearance S_{max} *		O-Ring Cross-Section-Ø
	Standard Range	Available Range	D_1 H9	$L_1 +0.2$	r_1	10 MPa	30 MPa	d_2
TG50	12 - 18.9	10 - 18.9	$d_N + 4.9$	2.20	0.40	0.20	0.10	1.78
TG51	19 - 37.9	12 - 59.9	$d_N + 7.5$	3.20	0.60	0.25	0.15	2.62
TG52	38 - 132.9	19 - 199.9	$d_N + 11.0$	4.20	1.00	0.30	0.20	3.53
TG53	133 - 255.9	38 - 329.9	$d_N + 15.5$	6.30	1.30	0.35	0.25	5.33
TG54	256 - 649.9	120 - 655.0	$d_N + 21.0$	8.10	1.80	0.40	0.25	7.00
TG55	650 - 999.9	650 - 999.9	$d_N + 28.0$	9.50	2.50	0.50	0.30	8.40
TG55X**	1,000 - 2,600	-	$d_N + 28.0$	9.50	2.50	0.50	0.30	8.40

* For max. temperature = +60 °C at the seal.

** Z53 and Z54 max. ø 2,200 mm.

ORDERING EXAMPLE

Zurcon® Roto Glyd Ring® S, complete with O-Ring, standard application:

Series:	TG52 from Table 90
Shaft diameter:	$d_N = 80.0$ mm
TSS Part No.:	TG5200800 from Table 91

Select the material from Table 89. The corresponding code numbers are appended to the TSS Part No. Together they form the TSS Article No. The TSS Article No. for all intermediate sizes not shown in Table 91 can be determined from the example below.

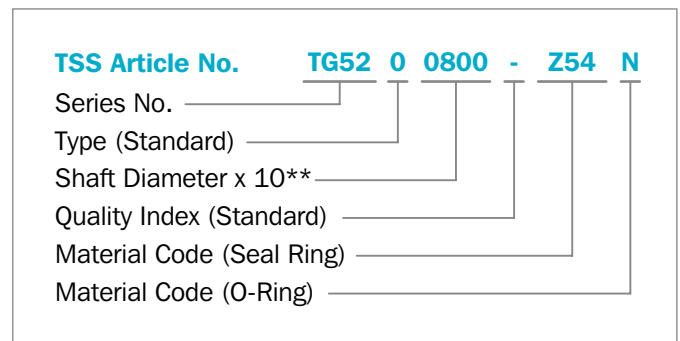

** For diameters $\geq 1,000.0$ mm multiply only by factor 1.

Example: TG55X for diameter 1,200.0 mm
TSS Article No.: TG55X**1200** - Z54N



Table 91: Standard Installation Dimensions / TSS Part Number

Shaft Dia.	Groove Dia.	Groove Width	TSS Part No.	O-Ring Sizes	Shaft Dia.	Groove Dia.	Groove Width	TSS Part No.	O-Ring Sizes
d_N f8/h9	D_1 H9	L_1 +0.2			d_N f8/h9	D_1 H9	L_1 +0.2		
10.0	14.9	2.2	TG5000100	12.42 x 1.80	150.0	165.5	6.3	TG5301500	158.12 x 5.33
12.0	16.9	2.2	TG5000120	14.00 x 1.78	160.0	175.5	6.3	TG5301600	170.82 x 5.33
14.0	18.9	2.2	TG5000140	15.60 x 1.78	170.0	185.5	6.3	TG5301700	177.17 x 5.33
15.0	19.9	2.2	TG5000150	17.17 x 1.78	180.0	195.5	6.3	TG5301800	189.87 x 5.33
16.0	20.9	2.2	TG5000160	18.77 x 1.78	190.0	205.5	6.3	TG5301900	202.57 x 5.33
18.0	22.9	2.2	TG5000180	20.35 x 1.78	200.0	215.5	6.3	TG5302000	208.92 x 5.33
20.0	27.5	3.2	TG5100200	23.47 x 2.62	210.0	225.5	6.3	TG5302100	221.62 x 5.33
22.0	29.5	3.2	TG5100220	25.07 x 2.62	220.0	235.5	6.3	TG5302200	227.97 x 5.33
25.0	32.5	3.2	TG5100250	28.24 x 2.62	230.0	245.5	6.3	TG5302300	240.67 x 5.33
28.0	35.5	3.2	TG5100280	31.42 x 2.62	240.0	255.5	6.3	TG5302400	247.02 x 5.33
30.0	37.5	3.2	TG5100300	34.59 x 2.62	250.0	265.5	6.3	TG5302500	266.07 x 5.30
32.0	39.5	3.2	TG5100320	36.17 x 2.62	280.0	301.0	8.1	TG5402800	291.47 x 7.00
35.0	42.5	3.2	TG5100350	39.34 x 2.62	300.0	321.0	8.1	TG5403000	304.17 x 7.00
36.0	43.5	3.2	TG5100360	39.34 x 2.62	320.0	341.0	8.1	TG5403200	329.57 x 7.00
40.0	51.0	4.2	TG5200400	47.22 x 3.53	350.0	371.0	8.1	TG5403500	354.97 x 7.00
42.0	53.0	4.2	TG5200420	47.22 x 3.53	360.0	381.0	8.1	TG5403600	367.67 x 7.00
45.0	56.0	4.2	TG5200450	50.39 x 3.53	400.0	421.0	8.1	TG5404000	405.26 x 7.00
48.0	59.0	4.2	TG5200480	53.57 x 3.53	500.0	521.0	8.1	TG5405000	506.86 x 7.00*
50.0	61.0	4.2	TG5200500	56.74 x 3.53	600.0	621.0	8.1	TG5406000	608.08 x 7.00*
52.0	63.0	4.2	TG5200520	59.92 x 3.53	700.0	728.0	9.5	TG5507000	712.90 x 8.40*
55.0	66.0	4.2	TG5200550	59.92 x 3.53	800.0	828.0	9.5	TG5508000	812.90 x 8.40*
56.0	67.0	4.2	TG5200560	63.09 x 3.53	900.0	928.0	9.5	TG5509000	912.90 x 8.40*
60.0	71.0	4.2	TG5200600	66.27 x 3.53	1,000.0	1,028.0	9.5	TG55X1000	1,012.90 x 8.40*
63.0	74.0	4.2	TG5200630	69.44 x 3.53	1,500.0	1,528.0	9.5	TG55X1500	1,512.90 x 8.40*
65.0	76.0	4.2	TG5200650	72.62 x 3.53	2,000.0	2,028.0	9.5	TG55X9200	2,012.90 x 8.40*
70.0	81.0	4.2	TG5200700	75.79 x 3.53	2,500.0	2,528.0	9.5	TG55X2500	2,512.90 x 8.40*
75.0	86.0	4.2	TG5200750	82.14 x 3.53					
80.0	91.0	4.2	TG5200800	85.32 x 3.53					
85.0	96.0	4.2	TG5200850	91.67 x 3.53					
90.0	101.0	4.2	TG5200900	98.02 x 3.53					
95.0	106.0	4.2	TG5200950	101.19 x 3.53					
100.0	111.0	4.2	TG5201000	107.54 x 3.53					
105.0	116.0	4.2	TG5201050	110.72 x 3.53					
110.0	121.0	4.2	TG5201100	117.07 x 3.53					
115.0	126.0	4.2	TG5201150	120.24 x 3.53					
120.0	131.0	4.2	TG5201200	126.59 x 3.53					
125.0	136.0	4.2	TG5201250	132.94 x 3.5					
130.0	141.0	4.2	TG5201300	136.12 x 3.53					
135.0	150.5	6.3	TG5201300	142.24 x 5.33					
140.0	155.5	6.3	TG5301400	148.59 x 5.33					

The shaft diameters printed in **bold** type conform to the recommendations of ISO 3320.

Other dimensions and all intermediate sizes up to 2,200 mm diameter for Z53 and Z54 (2,600 mm for Z80) including inch sizes can be supplied.

* Theoretical ideal O-Ring size



■ Installation Recommendation for Bore

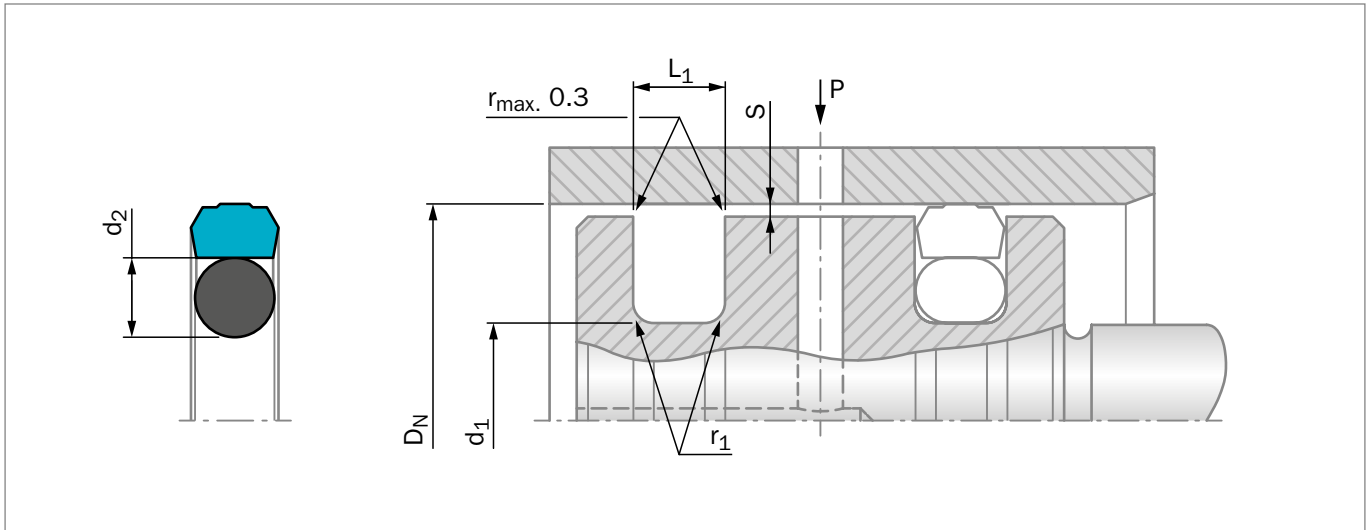

Figure 137 Installation Drawing

Table 92: Installation Dimensions – Standard Recommendations

Series Number	Bore Diameter D_N f8/h9		Groove Diameter*	Groove Width	Radius	Radial Clearance S_{max} *		O-Ring Cross-Section-Ø
	Standard Range	Available Range	d_1 h9	$L_1 +0.2$	r_1	10 MPa	30 MPa	d_2
TG60	12 - 19.9	10 - 24.9	$D_N - 4.9$	2.20	0.40	0.20	-	1.78
TG61	20 - 39.9	14 - 69.9	$D_N - 7.5$	3.20	0.60	0.25	0.15	2.62
TG62	40 - 132.9	22 - 199.9	$D_N - 11.0$	4.20	1.00	0.30	0.20	3.53
TG63	133 - 255.9	40 - 329.9	$D_N - 15.5$	6.30	1.30	0.35	0.25	5.33
TG64	256 - 669.9	133 - 690.0	$D_N - 21.0$	8.10	1.80	0.40	0.25	7.00
TG65	670 - 999.9	670 - 999.9	$D_N - 28.0$	9.50	2.50	0.45	0.30	8.40
TG65X**	1,000 - 2,700	-	$D_N - 28.0$	9.50	2.50	0.45	0.30	8.40

* For max. temperature = +60 °C at the seal.

** Z53 and Z54 max. \varnothing 2,300 mm

ORDERING EXAMPLE

Zurcon® Roto Glyd Ring® S, complete with O-Ring, standard application:

Series:	TG62 from Table 92
Bore diameter:	$D_N = 80.0$ mm
TSS Part No.:	TG6200800 from Table 93

Select the material from Table 88. The corresponding code numbers are appended to the TSS Part No. Together they form the TSS Article No. The TSS Article No. for all intermediate sizes not shown in Table 91 can be determined following the example opposite.

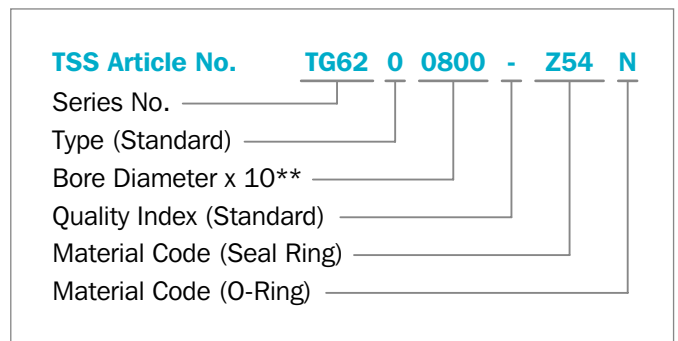

** For diameters $D_N \geq 1,000.0$ mm multiply only by factor 1.

Example: TG65X for diameter D_N 1,200.0 mm
TSS Article No.: TG65X**1200** - Z54N.



Table 93: Standard Installation Dimensions / TSS Part Number

Bore Dia.	Groove Dia.	Groove Width	TSS Part No.	O-Ring Sizes	Bore Dia.	Groove Dia.	Groove Width	TSS Part No.	O-Ring Sizes
D _N f8/h9	d ₁ H9	L ₁ +0.2			D _N f8/h9	d ₁ H9	L ₁ +0.2		
12.0	7.1	2.2	TG6000120	7.10 x 1.80	200.0	184.5	6.3	TG6302000	189.87 x 5.33
14.0	9.1	2.2	TG6000140	9.25 x 1.78	210.0	194.5	6.3	TG6302100	196.22 x 5.33
15.0	10.1	2.2	TG6000150	10.60 x 1.80	220.0	204.5	6.3	TG6302200	208.92 x 5.33
16.0	11.1	2.2	TG6000160	11.20 x 1.80	230.0	214.5	6.3	TG6302300	215.27 x 5.33
18.0	13.1	2.2	TG6000180	13.20 x 1.80	240.0	224.5	6.3	TG6302400	227.92 x 5.33
20.0	12.5	3.2	TG6100200	12.37 x 2.62	250.0	234.5	6.3	TG6302500	240.67 x 5.33
22.0	14.5	3.2	TG6100220	14.50 x 2.65	280.0	259.0	8.1	TG6402800	266.07 x 7.00
25.0	17.5	3.2	TG6100250	18.00 x 2.65	300.0	279.0	8.1	TG6403000	278.77 x 7.00
28.0	20.5	3.2	TG6100280	20.29 x 2.65	320.0	299.0	8.1	TG6403200	304.17 x 7.00
30.0	22.5	3.2	TG6100300	23.47 x 2.65	350.0	329.0	8.1	TG6403500	329.57 x 7.00
32.0	24.5	3.2	TG6100320	25.07 x 2.65	400.0	379.0	8.1	TG6404000	380.37 x 7.00
35.0	27.5	3.2	TG6100350	28.24 x 2.65	420.0	399.0	8.1	TG6404200	405.26 x 7.00
40.0	29.0	4.2	TG6200400	29.75 x 3.53	450.0	429.0	8.1	TG6404500	430.66 x 7.00
42.0	31.0	4.2	TG6200420	31.35 x 3.53	480.0	459.0	8.1	TG6404800	468.76 x 7.00
45.0	34.0	4.2	TG6200450	34.52 x 3.53	500.0	479.0	8.1	TG6405000	481.38 x 7.00
48.0	37.0	4.2	TG6200480	37.69 x 3.53	600.0	579.0	8.1	TG6406000	582.68 x 7.00
50.0	39.0	4.2	TG6200500	40.87 x 3.53	700.0	672.0	9.5	TG6507000	670.00 x 8.40*
52.0	41.0	4.2	TG6200520	40.87 x 3.53	800.0	772.0	9.5	TG6508000	770.30 x 8.40*
55.0	44.0	4.2	TG6200550	44.04 x 3.53	900.0	872.0	9.5	TG6509000	870.30 x 8.40*
56.0	45.0	4.2	TG6200560	47.22 x 3.53	1,000.0	972.0	9.5	TG65X1000	970.30 x 8.40*
60.0	49.0	4.2	TG6200600	50.39 x 3.53	1,500.0	1,472.0	9.5	TG65X1500	1,470.30 x 8.40*
63.0	52.0	4.2	TG6200630	53.57 x 3.53	2,000.0	1,972.0	9.5	TG65X2000	1,970.30 x 8.40*
65.0	54.5	4.2	TG6300650	56.74 x 5.33	2,500.0	2,472.0	9.5	TG65X2500	2,470.30 x 8.40*
80.0	69.0	4.2	TG6200800	69.44 x 3.53					
85.0	74.0	4.2	TG6200850	75.79 x 3.53					
90.0	79.0	4.2	TG6200900	78.97 x 3.53					
95.0	84.0	4.2	TG6200950	85.32 x 3.53					
100.0	89.0	4.2	TG6201000	91.67 x 3.53					
110.0	99.0	4.2	TG6201100	101.19 x 3.53					
115.0	104.0	4.2	TG6201150	104.37 x 3.53					
120.0	109.0	4.2	TG6201200	110.72 x 3.53					
125.0	114.0	4.2	TG6201250	117.07 x 3.53					
130.0	119.0	4.2	TG6201300	120.24 x 3.53					
135.0	119.5	6.3	TG6301350	120.02 x 5.33					
140.0	124.5	6.3	TG6301400	126.37 x 5.33					
150.0	134.5	6.3	TG6301500	135.89 x 5.33					
160.0	144.5	6.3	TG6301600	145.42 x 5.33					
170.0	154.5	6.3	TG6301700	158.12 x 5.33					
180.0	164.5	6.3	TG6301800	164.47 x 5.33					
190.0	174.5	6.3	TG6301900	177.17 x 5.33					

The bore diameters printed in **bold** type conform to the recommendations of ISO 3320.

Other dimensions and all intermediate sizes up to 2,300 mm diameter for Z53 and Z54 (2,700 mm for Z80) including inch sizes can be supplied.

* Theoretical ideal O-Ring size



Turcon[®] Roto Variseal







■ Turcon® Roto Variseal®

■ Description

The Turcon® Roto Variseal® is a single-acting seal consisting of a U-shaped seal jacket and a V-shaped corrosion resistant metal spring.

The characteristic of the Roto Variseal® is the flanged heel, which prevents the seal from rotating by clamping in the groove and the short and heavy dynamic lip offering reduced friction, long service life and a good scraping effect even in highly viscous media.

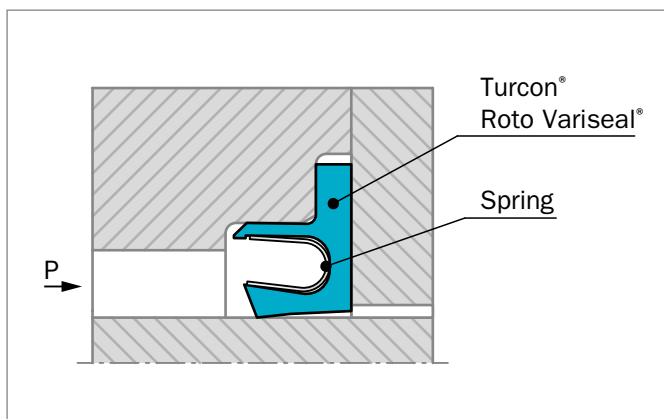

Figure 138 Turcon® Roto Variseal®

At low and zero pressure, the metal spring provides the primary sealing force. As the system pressure increases, the main sealing force is achieved by the system pressure and ensures a tight seal from zero to high pressure.

The possibility of matching suitable materials for the seal and the spring allows use in a wide range of applications going beyond the field of hydraulics, e.g. in the chemical, pharmaceutical and foodstuffs industry.

The Roto Variseal® can be sterilized and is available in a special Hi-Clean version where the spring cavity is filled with a Silicone elastomer preventing contaminants from being entrapped in the seal. This design also works well in applications involving mud, slurries or adhesives to keep grit from packing into the seal cavity and inhibiting the spring action.

ADVANTAGES

- Suitable for rotary, reciprocating and static applications
- Protects against mechanical torsion
- Low coefficient of friction
- Remains tight in groove even when subject to oscillating or helical movements
- Withstands rapid changes in temperature
- High abrasion resistance
- Excellent resistance to aging
- Good scraping ability
- Can be sterilized
- Available in Hi-Clean version

OPERATING CONDITIONS

Operating Pressure:	For dynamic loads: 15 MPa For static loads: 25 MPa
Speed:	Rotating: Up to 2 m/s
Temperature:	-100 °C to +260 °C For specific applications at lower temperatures, please enquire
Media:	Virtually all fluids, chemicals and gases

IMPORTANT NOTE

The above data are maximum values and cannot be used at the same time, e. g. the maximum operating speed depends on material type, pressure and temperature.



FRICITIONAL FORCE

Indicative values for frictional force are included in Figure 139. Frictional force is given as a function of sliding speed and operating pressure for a shaft diameter of 50 mm (2 inches) at an oil temperature of 60 °C. The operating limits are lower at higher temperatures.

Indicative values for other shaft diameters can be calculated from the formula:

$$P \approx P_{50} \times \left(\frac{d}{50 \text{ mm}} \right) [W]$$

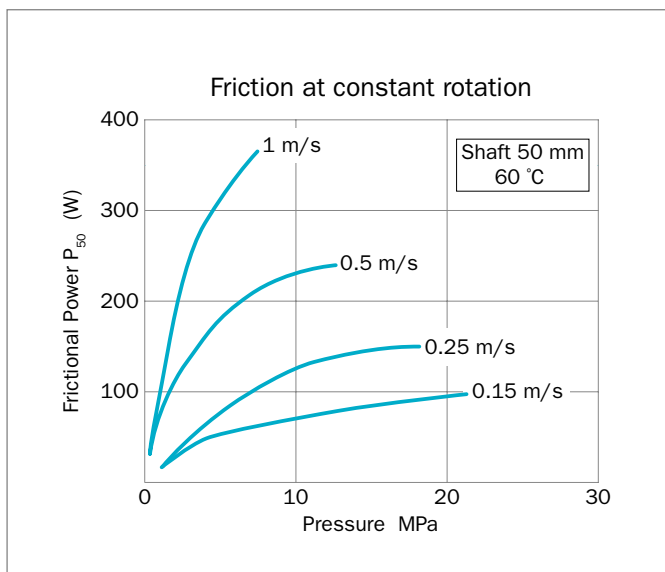

Figure 139 Frictional power for Turcon® Roto Variseal®

The indicative values apply for constant operating conditions. Changes in these, such as pressure fluctuations or direction of rotation can result in significantly higher frictional values.

APPLICATION EXAMPLES

The Turcon® Roto Variseal® is used as a single acting rotary seal in sectors such as:

- Rotary injection units (injection molding machines)
- Rotary distributors
- Pivoting motors in pharmacy, industry, machine tools, foodstuff and chemical

APPLICATION LIMITS

The maximum operating limits for temperature, pressure and speed are dependent upon one another and therefore cannot all apply at the same time.

The lubrication properties of the media to be sealed and heat dissipation must also be taken into consideration.

The following pv values can be used as general guidelines:

- Poor lubrication up to $p v = 2 \text{ MPa} \times \text{m/s}$
- Good lubrication up to $p v = 5 \text{ MPa} \times \text{m/s}$
- Very good cooling up to $p v = 5 \text{ MPa} \times \text{m/s}$

These values are lower for diameters < 50 mm (2 inches). Tests of these characteristics are recommended to establish application limits.

MATERIALS

All materials used are physiologically safe. They contain no odour or taste-affecting substances.

The following standard material combination has proved effective for most applications:

- Seal ring: Turcon® T40
- Spring: Stainless Steel Material No. AISI 301

For use in accordance with the demands of the "Food and Drug Administration", suitable materials are available on request.

LEAD-IN CHAMFERS

In order to avoid damage during installation, lead-in chamfers and rounded edges must be provided on the housing and on the rod (Figure 140). If this is not possible for design reasons, a separate installation tool is recommended.

The minimum length of the lead-in chamfer depends on the profile size of the seal and can be seen from the following tables. If concentricity between the parts is not ensured during installation the lead-in chamfers must be increased correspondingly.

For the surface quality of the lead-in chamfer, the same recommendations apply as given for the sealing surfaces in Table 96.

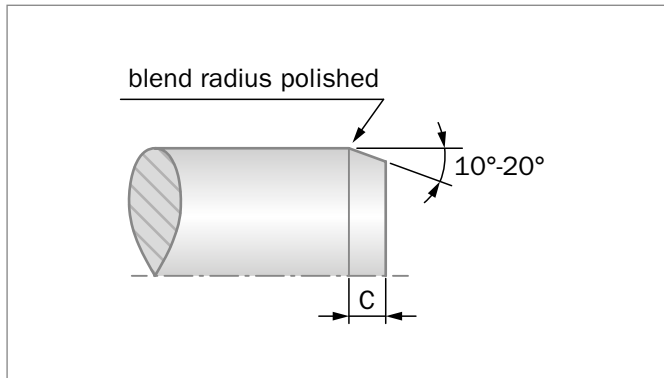

Figure 140 Lead-in chamfer on shaft

Table 94: Lead-in chamfers for Turcon® Roto Variseal®

Series	Lead-in Chamfers Length C min.
TVM1	4.5
TVM2	5.0
TVM3	8.0
TVM4	12.0

MATING SURFACE MATERIALS

Sealing of applications with rotating movements require very good mating surfaces. A minimum hardness 55 HRC is recommended to a harding depth of at least 0.3 mm. Particular attention must be paid to coated surfaces and good heat dissipation through the coating is required.

SHAFT BEARING/RADIAL CLEARANCE FOR BEARING

In general the sealing elements should not take on any bearing tasks as this will reduce the functioning of the seals. Consequently we recommend to guide the components by means of a roller or slide bearing.

INSTALLATION INSTRUCTIONS

The following points should be observed before installation of the seals:

- Check whether housing or rod has a lead-in chamfer; if not, use an installation sleeve
- Deburr and chamfer or round sharp edges, cover the tips of any screw threads
- Remove machining residues such as chips, dirt and other foreign particles and carefully clean all parts
- If the seals are installed with grease or oil, attention must be paid to the compatibility of the seal materials with these lubricants. Use only grease without solid additives (e.g. molybdenum disulfide or zinc sulfide)
- Do not use installation tools with sharp edges

INSTALLATION OF TURCON® ROTO VARISEAL®

Turcon® Roto Variseal® is installed in split grooves.

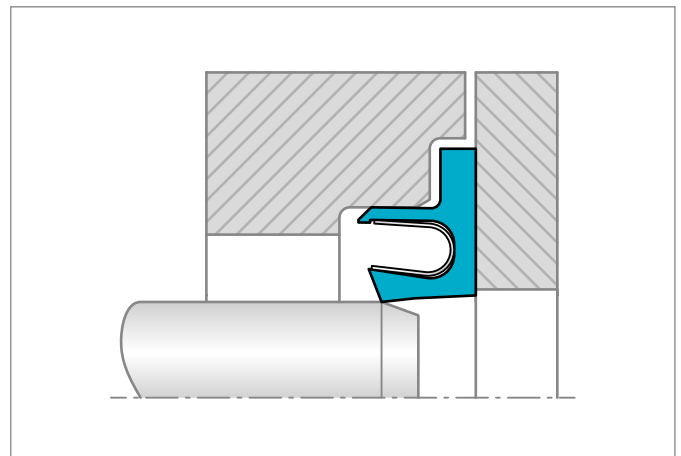

Figure 141 Turcon® Roto Variseal®

Installation should be performed in the following steps in order to ensure a concentric and strain-free fit:

- Place the seal ring in into the open groove
- Fit the cover loosely onto the housing
- Insert the shaft
- Tighten the cover



Table 95: Standard Turcon® Materials for Roto Variseal®

Material, Applications, Properties	Code	Spring Material	Code	Operating Temp.* °C	Mating Surface Material	MPa max.
Turcon® T40 For all lubricating and non-lubricating Hydraulic fluids, water hydraulics, soft mating surfaces Carbon fiber filled Color: Gray	T40	Spring material AISI 301	S	-100 to +260	Steel Steel, chrome plated Cast iron Stainless steel Aluminum Bronze Alloys	15
Turcon® T78 For all lubricated and non-lubricated applications, soft mating surfaces Aromatic polymer Color: Tan to dark brown	T78	Spring material AISI 301	S	-100 to +260	Steel Steel, chrome plated Cast iron Stainless steel	5

Highlighted materials are standard.

Trelleborg Sealing Solutions recommends that the following surface finishes be observed:

Table 96: Surface Roughness

Media	Shaft surface ¹⁾	Static groove surface
Cryogenic and low molecular gases Hydrogen, Helium, Freon, Oxygen Nitrogen	$R_{max} = 1.0 \mu\text{m}$ $R_z = 0.63 \mu\text{m}$ $R_a = 0.1 \mu\text{m}$	$R_{max} = 3.5 \mu\text{m}$ $R_z = 2.2 \mu\text{m}$ $R_a = 0.3 \mu\text{m}$
Low viscosity fluids Water, Alcohols, Hydrazine, Gaseous nitrogen, Natural gas, Skydrol, air	$R_{max} = 2.5 \mu\text{m}$ $R_z = 1.6 \mu\text{m}$ $R_a = 0.2 \mu\text{m}$	$R_{max} = 5.0 \mu\text{m}$ $R_z = 3.5 \mu\text{m}$ $R_a = 0.6 \mu\text{m}$
High viscosity fluids Hydraulic oils, Crude oil, Gear oil, Sealants, Glue, Milk products	$R_{max} = 2.5 \mu\text{m}$ $R_z = 1.6 \mu\text{m}$ $R_a = 0.2 \mu\text{m}$	$R_{max} = 6.5 \mu\text{m}$ $R_z = 5.0 \mu\text{m}$ $R_a = 0.8 \mu\text{m}$

1) The sealing surface must be free from spiral grooves.
 The material contact area R_{mr} should be approx. 50 to 70%, determined at a cut depth $c = 0.25 \times R_z$, relative to a reference line of C_{ref} . 5%.



■ Installation Recommendation

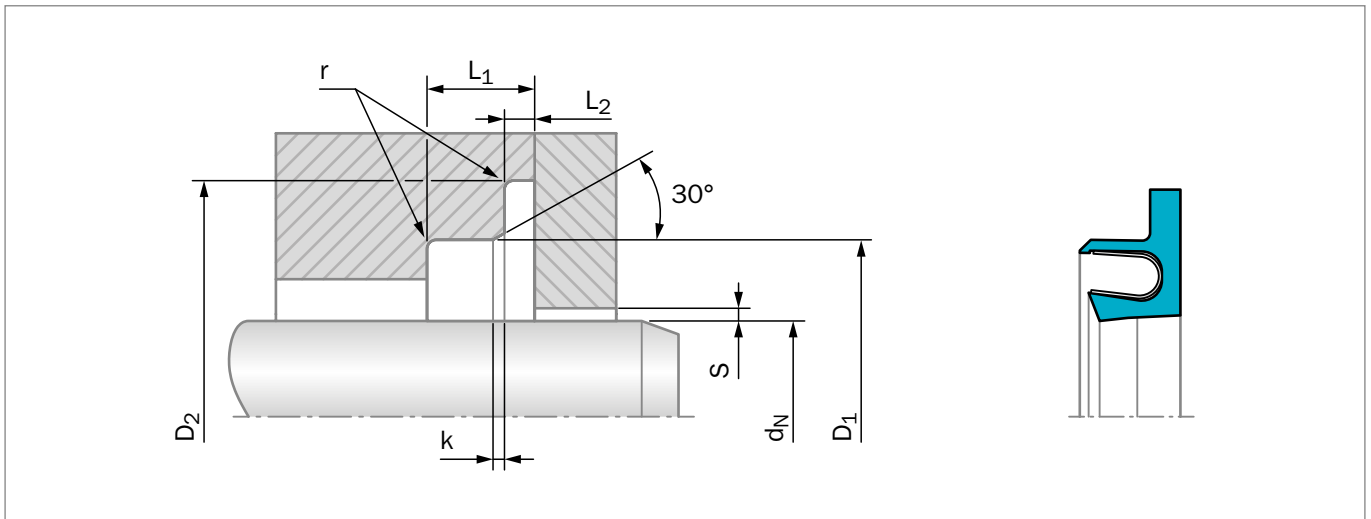

Figure 142 Installation Drawing

Table 97: Installation Dimensions

Series Number	Rod Diameter d_N f8/h9		Groove Diameter		Groove Width		Radius r	Radial Clearance S_{max}		
	Standard Range	Available Range ¹⁾	D_1 H9	D_2 H10	L_1 min	L_2		< 2 MPa	< 10 MPa	< 20 MPa
TVM1	5.0 - 19.9	20.0 - 200.0	$d + 5.0$	$d + 9.0$	3.6	$0.85_{+0/-0.1}$	0.3	0.25	0.15	0.10
TVM2	20.0 - 39.9	10.0 - 400.0	$d + 7.0$	$d + 12.5$	4.8	$1.35_{+0/-0.15}$	0.4	0.35	0.20	0.15
TVM3	40.0 - 399.9	20.0 - 700.0	$d + 10.5$	$d + 17.5$	7.1	$1.80_{+0/-0.20}$	0.5	0.50	0.25	0.20
TVM4	400.0 - 999.9	35.0 - 999.9	$d + 14.0$	$d + 22.0$	9.5	$2.80_{+0/-0.20}$	0.5	0.60	0.30	0.25

¹⁾ Available on request. Application of a seal series outside of the standard range can impair seal performance and stability and should only be made after careful testing and evaluation.



ORDERING EXAMPLE TURCON® ROTO VARISEAL®

Series:	TVM3 (from Table 97)
Rod Diameter:	$d_N = 80.0$ mm
TSS Part No.:	TVM300800 (from Table 98)

Select the material from Table 95. The corresponding code numbers are appended to the TSS Part No. (from Table 98). Together they form the TSS Article No. For all intermediate sizes not shown in Table 97, the TSS Article No. can be determined from the example opposite.

* For diameters $\geq 1,000.0$ mm multiply only by factor 1.
 Example: TVM4 for diameter 1,200.0 mm.
 TSS Article No.: TVM4X1200 - T40S.

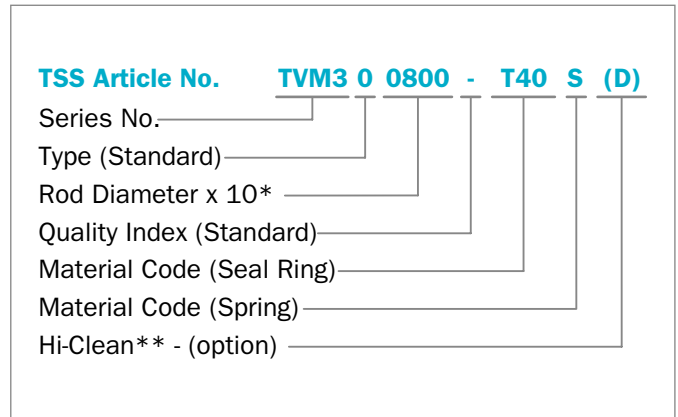

** Roto Variseal® are available with the spring groove filled with high temperature silicone. The silicone prevents entrapment of biological contaminants in the seal making the seal easier to clean.

Table 98: Preferred Dimension / TSS Part Number

Rod Diameter d_N f8/h9	Groove Diameter		Groove Width L_1	TSS Part No.
	D_1 H9	D_2 H10		
5.0	10.0	14.0	3.6	TVM100050
6.0	11.0	15.0	3.6	TVM100060
8.0	13.0	17.0	3.6	TVM100080
10.0	15.0	19.0	3.6	TVM100100
12.0	17.0	21.0	3.6	TVM100120
14.0	19.0	23.0	3.6	TVM100140
15.0	20.0	24.0	3.6	TVM100150
16.0	21.0	25.0	3.6	TVM100160
18.0	23.0	27.0	3.6	TVM100180
20.0	27.0	32.5	4.8	TVM200200
22.0	29.0	34.5	4.8	TVM200220
25.0	32.0	37.5	4.8	TVM200250
28.0	35.0	40.5	4.8	TVM200280
30.0	37.0	42.5	4.8	TVM200300
32.0	39.0	44.5	4.8	TVM200320
35.0	42.0	47.5	4.8	TVM200350
36.0	43.0	48.5	4.8	TVM200360
40.0	50.5	57.5	7.1	TVM300400
42.0	52.5	59.5	7.1	TVM300420
45.0	55.5	62.5	7.1	TVM300450
48.0	58.5	65.5	7.1	TVM300480
50.0	60.5	67.5	7.1	TVM300500
52.0	62.5	69.5	7.1	TVM300520
55.0	65.5	72.5	7.1	TVM300550
56.0	66.5	73.5	7.1	TVM300560

Rod Diameter d_N f8/h9	Groove Diameter		Groove Width L_1	TSS Part No.
	D_1 H9	D_2 H10		
60.0	70.5	77.5	7.1	TVM300600
63.0	73.5	80.5	7.1	TVM300630
65.0	75.5	82.5	7.1	TVM300650
70.0	80.5	87.5	7.1	TVM300700
75.0	85.5	92.5	7.1	TVM300750
80.0	90.5	97.5	7.1	TVM300800
85.0	95.5	102.5	7.1	TVM300850
90.0	100.5	107.5	7.1	TVM300900
95.0	105.5	112.5	7.1	TVM300950
100.0	110.5	117.5	7.1	TVM301000
105.0	115.5	122.5	7.1	TVM301050
110.0	120.5	127.5	7.1	TVM301100
115.0	125.5	132.5	7.1	TVM301150
120.0	130.5	137.5	7.1	TVM301200
125.0	135.5	142.5	7.1	TVM301250
130.0	140.5	147.5	7.1	TVM301300
135.0	145.5	152.5	7.1	TVM301350
140.0	150.5	157.5	7.1	TVM301400
150.0	160.5	167.5	7.1	TVM301500
160.0	170.5	177.5	7.1	TVM301600
170.0	180.5	187.5	7.1	TVM301700
180.0	190.5	197.5	7.1	TVM301800
190.0	200.5	207.5	7.1	TVM301900
200.0	210.5	217.5	7.1	TVM302000
210.0	220.5	227.5	7.1	TVM302100



Rod Diameter	Groove Diameter		Groove Width	TSS Part No.
	d_N f8/h9	D_1 H9		
220.0	230.5	237.5	7.1	TVM302200
230.0	240.5	247.5	7.1	TVM302300
240.0	250.5	257.5	7.1	TVM302400
250.0	260.5	267.5	7.1	TVM302500
280.0	290.5	297.5	7.1	TVM302800
300.0	310.5	317.5	7.1	TVM303000
320.0	330.5	337.5	7.1	TVM303200
350.0	360.5	367.5	7.1	TVM303500
360.0	370.5	377.5	7.1	TVM303600
420.0	434.0	442.0	9.5	TVM404200
450.0	464.0	472.0	9.5	TVM404500
480.0	494.0	502.0	9.5	TVM404800
500.0	514.0	522.0	9.5	TVM405000
600.0	614.0	622.0	9.5	TVM406000
700.0	714.0	722.0	9.5	TVM407000

The rod diameters printed in **bold** type conform to the recommendations of ISO 3320.

Other dimensions and all intermediate sizes up to 2,500 mm diameter including inch sizes can be supplied.



Turcon[®] Roto VL Seal[®] F







■ Turcon® Roto VL Seal® F

■ Description

Turcon® Roto VL Seal® F is an O-Ring energized, single-acting seal intended for rotary and swivelling movements. The seal is specially designed for rotary applications with medium to high system pressure. It covers both shaft and bore installations.

It is a further development of the Turcon® Roto VL Seal® design with the extra feature of having a flange which is clamped in the groove preventing the seal from rotating, see page Figure 143.

The single acting Roto VL Seal® F is a combination of a Turcon® based slipper seal and an energizing O-Ring. It has an interference fit which together with the squeeze of the O-Ring ensures a good sealing effect even at low pressure. At higher system pressures the O-Ring is energized by the fluid pushing Roto VL Seal® F against the sealing face with increased force.

Roto VL Seal® F has very high static sealing effect in the groove provided by the O-Ring, which is protected from damage from pressure cycles by the supporting concave seal back. By clamping the flanged Turcon® Roto VL Seal® F in the groove keeps it in position also at high working pressure

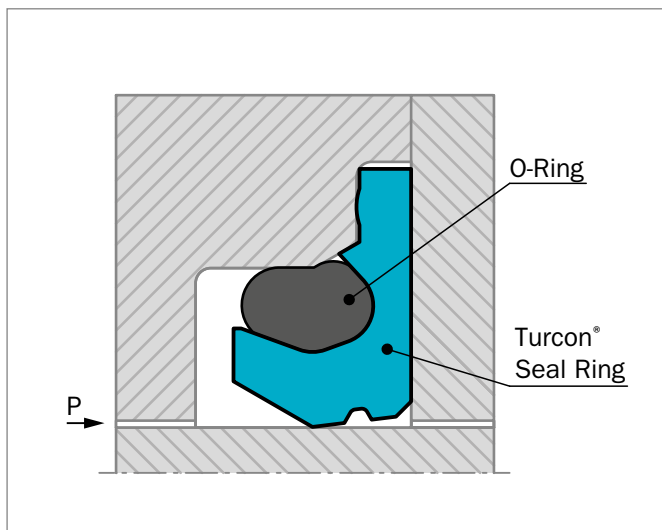

Figure 143: Turcon® Roto VL Seal® F

Roto VL Seal® F offers improved performance in terms of high dynamic seal efficiency, low friction and static sealing by an elastomer component.

ADVANTAGES

- Available for shaft and bore sealing applications
- For rotary, turning and helical movements
- Low friction
- Stick-slip-free starting, no sticking
- High static sealing effect
- High dimensional stability
- Lubricant reservoir
- Available in Turcon® and Zurcon® materials
- Available in most materials in all sizes up to 2,600 mm for shaft seals and to 2,700 mm for bore seals
- The specific O-Ring position eliminates the static seal element normally applied in a split groove assembly
- Fit into standard Turcon® Roto Variseal® grooves.

APPLICATIONS EXAMPLES

The seal is used in hydraulics and general machine construction as an alternative to other single-acting seals according to their individual advantages in:

- Rolling Mills: Bearing Grease Seals
- Tool Machine Industry, mainly Machining Centres
- Hydraulic Swivels
- Injection Moulding Machines: Rotary Injection Unit
- Valve Spindles
- Food Processing: Blender and Mixers
- Hydraulic Steering Units
- Hydraulic Rotator: Forest machines
- Rotator for Handling Devices
- Vane Actuators / Motors
- Hydraulic Motors
- Hydraulic Pumps
- Propeller Thrusters
- ROV (Remotely Operated Vehicle)



OPERATING CONDITIONS

Seal performance is influenced by such factors as lubrication capability of the sealed media and heat dissipation in the hardware. Therefore testing should always be carried out. With good lubrication, the following values can be used:

Movement:	Rotary and oscillating
Pressure:	Up to 30 MPa (40 MPa short term or static) (depending on seal material)
Speed:	Up to 2 m/s and/or 1000 rpm according to seal material
Temperature:	Turcon® materials: -40 to +120 °C *) (+200 °C static) according to O-Ring material Zurcon® Z54: -40 to +80 °C *) (+100 °C short term or static) according to O-Ring material Zurcon® Z80: -40 to +60 °C *) (+80 °C short term or static) according to O-Ring material
Media:	Mineral oil-based hydraulic fluids, flame-retardant hydraulic fluids, environmentally friendly hydraulic fluids (bio-oils), water and others, depending on seal and elastomer material.
Availability:	Shaft diameters from 6 to 2,600 mm (2,200 for Zurcon® Z54) Bore diameters from 14 to 2,700 mm (2,300 for Zurcon® Z54)
Caution with:	Operating at temperatures above +80 °C, use O-Rings in HNBR or FKM Rotary service on shafts and bores with poor heat dissipation Shaft and bores with hardness below s50 HRC Constant rotation for Zurcon® materials

IMPORTANT NOTE

The above data are maximum values and cannot be used at the same time, e. g. the maximum operating speed depends on material type, pressure, temperature and gap value. Temperature range also depends on the media.

*) IMPORTANT NOTE FOR THE BORE VERSION:

In the case of unpressurized applications in temperatures below °C please contact your local Trelleborg Sealing Solutions marketing company for more information.

FRICTIONAL POWER

Guide values for the frictional power (P) can be determined from the graph in page Figure 144. They are shown as a function of the sliding speed and operating pressure for a shaft diameter of 50 mm with an oil temperature of 60 °C. At higher temperatures, these application limits must be reduced.

Formula for other diameters d:

$$P = \frac{P_{50} \times (d)}{(50 \text{ mm})} \text{ [W]}$$

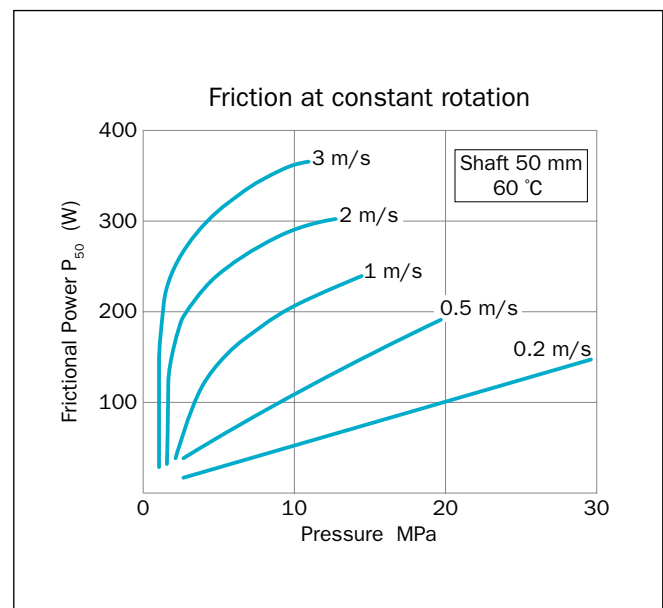

Figure 144: Frictional power for Turcon® VL Seal® F

The guide values apply for constant operating conditions. Pressure fluctuations or alternating directions of shaft rotation can result in considerably higher friction values.



INSTALLATION INSTRUCTIONS

Roto VL Seal® F is installed according to information at page 309.

O-RING SIZE

O-Rings for Roto VL Seal® F are selected to suit the groove diameter:

For shaft seals the O-Ring should have OD equal to or smaller than groove diameter, for bore seals the O-Ring should have ID equal to or smaller than groove diameter.

RECOMMENDED MATERIALS

The following material combinations have proven effective for rotary applications:

Turcon® Roto VL Seal® F in Turcon® T40

All-round material choice in oil hydraulics, water and other fluids with limited lubrication:

O-Ring:	NBR 70 Shore A	N
	FKM 70 Shore A	V
	HNBR 70 Shore A	H
Set code:	T40N, T40V or T40H	

Turcon® Roto VL Seal® F in Turcon® in M15

Material with high sealing effect for light to medium applications in fluids with good lubrication:

O-Ring:	NBR 70 Shore A	N
	FKM 70 Shore A	V
	HNBR 70 Shore A	H
Set code:	M15N, M15V or M15H	

Applications where high resistance to abrasive wear is required Zurcon® Z54 and Z80 are recommended.

Z54 and Z80 are for slow turning motion and not for constant rotation.

For specific applications other Turcon® and Zurcon® materials are available.



Table 99: Turcon® and Zurcon® Materials

Material, Applications, Properties	Code	O-Ring Material Shore A	Code	O-Ring Operating Temp.* °C	Mating Surface Material	MPa max. Dynamic
Turcon® M12 For lubricated applications High compressive strength Low friction Tight surface texture High sealing effect Good sliding properties Good extrusion resistance Mineral fiber and additives filled Color: Dark green-gray	M12	NBR 70	N	-30 to +100	Steel hardend	15
		NBR 70 Low temp.	T	-45 to +80	Steel, chrome plated (shaft)	
		FKM 70	V	-10 to +200	Cast iron	
		HNBR 70	H	-30 to +150		
Turcon® M15 For lubricating fluids Excellent for rotary service High sealing effect Very good wear properties Low friction Polyaramid, mineral fiber, lubricant and graphite filled Color: Dark gray	M15	NBR 70	N	-30 to +100	Steel hardend	25
		NBR 70 Low temp.	T	-45 to +80	Steel chrome plated (shaft)	
		FKM 70	V	-10 to +200	Cast iron	
		HNBR 70	H	-30 to +150		
Turcon® T40 All round material for rotary and turning movements For lubricating fluids and fluids with low lubricating properties, e.g. water Surface texture not suitable for gases Carbon fiber filled Color: Gray	T40	NBR 70	N	-30 to +100	Steel	30
		NBR 70 Low temp.	T	-45 to +80	Steel chrome plated (shaft)	
		FKM 70	V	-10 to +200	Cast iron	
		HNBR 70	H	-30 to +150	Stainles steel Hard Alloys	
Zurcon® Z54** For lubricated applications High compressive strength Low friction Tight surface texture High sealing effect Good sliding properties Good extrusion resistance Mineral filled Color: Dark green-gray	Z52	NBR 70	N	-30 to +100	Steel	20
		NBR 70 Low temp.	T	-45 to +80	Steel hardend Steel, chrome plated (shaft) Stainless steel Ceramic coating	

Table is continued on next page



Material, Applications, Properties	Code	O-Ring Material Shore A	Code	O-Ring Operating Temp.* °C	Mating Surface Material	MPa max. Dynamic
Zurcon® Z80 For lubricating fluids and fluids with low lubricating properties***, water, air and gasses at low pressure Good abrasion resistance Good chemical resistance Not for constant rotation Max. working temperature +80 °C. Ultra high molecular weight polyethylene. Color: White to off-white	Z80	NBR 70	N	-30 to +80	Steel	20
		NBR 70 Low temp.	T	-45 to +80	Steel hardend Steel, chrome plated (shaft) Stainless steel Ceramic coating	

* The O-Ring operation temperature is only valid in mineral hydraulic oil.

** max. \varnothing 2,200 mm.

*** E.g. coolant fluids

Highlighted materials are recommended.



■ Installation Recommendation for Shaft

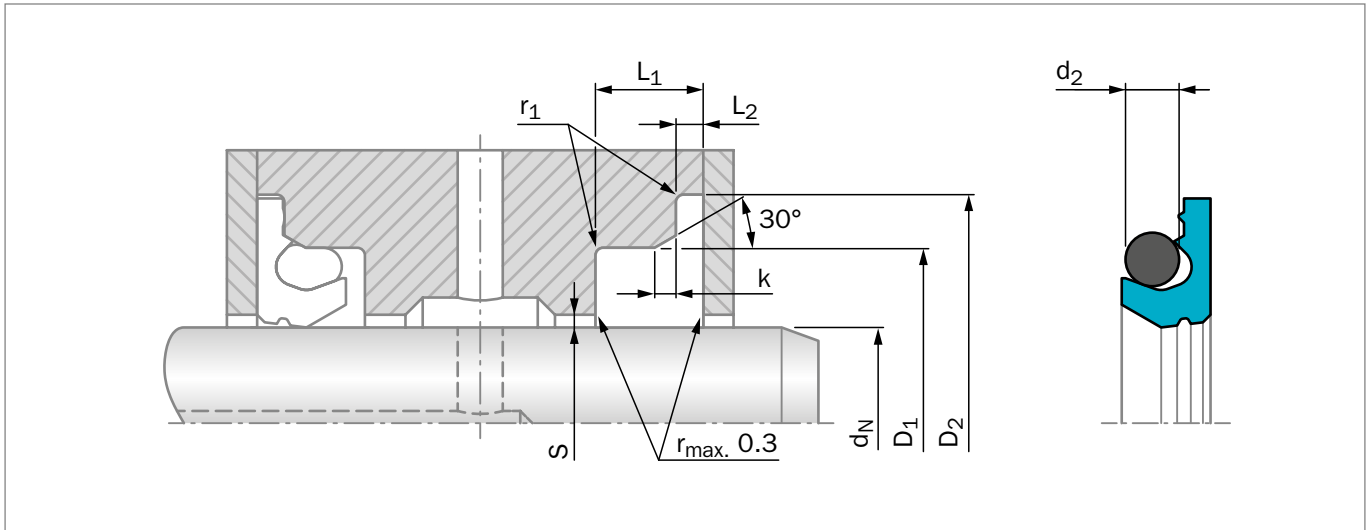

Figure 145: Installation Drawing

Table 100: Installation Dimensions – Standard Recommendations

Series Number	Shaft Diameter		Groove Diameter		Groove Width		Lead-in Chamfer	Ra- dius	Radial Clearance S _{max} *			O-Ring Cross-Section-Ø		
	d _N f8/h9		D ₁ H9	D ₂ H10	L ₁ min	L ₂			k	r ₁	10 MPa		20 MPa	30 MPa
	Recommended Range	Available Range												
TE310	10 - 19.9	6 - 100.0	d _N + 5.0	d _N + 9.0	3.6	0.85 +0/-0.10	0.8	0.3	0.20	0.15	-	1.78		
TE320	20 - 39.9	10 - 200.0	d _N + 7.0	d _N + 12.5	4.8	1.35 +0/-0.15	1.1	0.4	0.25	0.20	0.15	2.62		
TE330	40 - 119.9	20 - 400.0	d _N + 10.5	d _N + 17.5	7.1	1.80 +0/-0.20	1.4	0.5	0.30	0.25	0.20	3.53		
TE340	120 - 399.9	35 - 650.0	d _N + 14.0	d _N + 22.0	9.5	2.80 +0/-0.20	1.6	0.5	0.35	0.30	0.25	5.33		
TE350	400 - 649.9	125 - 999.9	d _N + 18.0	d _N + 28.0	12.2	3.50 +0/-0.20	2.0	0.8	0.40	0.35	0.30	7.00		
TE360	650 - 999.9	400 - 999.9	d _N + 22.0	d _N + 34.0	15.0	4.30 +0/-0.20	2.5	1.0	0.45	0.40	0.35	8.40		
TE36X	1,000 - 2,600	-	d _N + 22.0	d _N + 34.0	15.0	4.30 +0/-0.20	2.5	1.0	0.45	0.40	0.35	8.40		

* At pressures > 30 MPa: Use diameter tolerance H8/f8 (bore/shaft) in area of seal.

ORDERING EXAMPLE

Turcon® Roto VL Seal® F, complete with O-Ring, standard application:

Series: TE340 (from page Table 100)

Shaft diameter: d_N = 120 mm

TSS Part No.: TE3401200 (from page Table 101)

Select the material from page Table 99. The corresponding code numbers are appended to the TSS Part No. Together they form the TSS Article No. The TSS Article No. for all intermediate sizes not shown in page Table 101 can be determined following the example opposite.

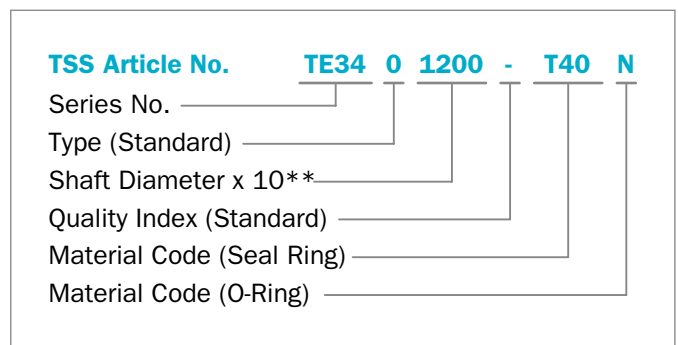

** For diameters d_N ≥ 1,000.0 mm multiply only by factor 1.
Example: TE36X for diameter d_N = 1,200.0 mm
TSS Article No.: TE36X1200-T40N



Table 101: Standard Installation Dimensions / TSS Part Number

Shaft Dia.	Groove Dia.	Groove Dia.	Groove Width	TSS Part No.	O-Ring Dimensions
d_N f8/h9	D_1 H9	D_2 H10	L_1 +0.20		
6.0	11.0	15.0	3.6	TE3100060	7.10 x 1.80
8.0	13.0	17.0	3.6	TE3100 080	9.25 x 1.78
10.0	15.0	19.0	3.6	TE3100100	11.20 x 1.80
12.0	17.0	21.0	3.6	TE3100120	13.20 x 1.80
14.0	19.0	23.0	3.6	TE3100140	15.60 x 1.78
15.0	20.0	24.0	3.6	TE3100150	16.32 x 1.78
16.0	21.0	25.0	3.6	TE3100160	17.17 x 1.78
18.0	23.0	27.0	3.6	TE3100180	19.00 x 1.80
20.0	27.0	32.5	4.8	TE3200200	21.89 x 2.62
22.0	29.0	34.5	4.8	TE3200220	23.47 x 2.62
25.0	32.0	37.5	4.8	TE3200250	26.64 x 2.62
28.0	35.0	40.5	4.8	TE3200280	29.82 x 2.62
30.0	37.0	42.5	4.8	TE3200300	31.42 x 2.62
32.0	39.0	44.5	4.8	TE3200320	34.59 x 2.62
35.0	42.0	47.5	4.8	TE3200350	36.17 x 2.62
36.0	43.0	48.5	4.8	TE3200360	37.77 x 2.62
40.0	50.5	57.5	7.1	TE3300400	44.04 x 3.53
42.0	52.5	59.5	7.1	TE3300420	44.04 x 3.53
45.0	55.5	62.5	7.1	TE3300450	47.22 x 3.53
48.0	58.5	65.5	7.1	TE3300480	50.39 x 3.53
50.0	59.4	67.5	7.1	TE3300500	53.57 x 3.53
52.0	62.5	69.5	7.1	TE3300520	56.74 x 3.53
55.0	65.5	72.5	7.1	TE3300550	59.92 x 3.53
56.0	66.5	73.5	7.1	TE3300560	59.92 x 3.53
60.0	70.5	77.5	7.1	TE3300600	63.09 x 3.53
63.0	73.5	80.5	7.1	TE3300630	66.27 x 3.53
65.0	75.5	82.5	7.1	TE3300650	69.44 x 3.53
70.0	80.5	87.5	7.1	TE3300700	72.62 x 3.53
75.0	85.5	92.5	7.1	TE3300750	78.97 x 3.53
80.0	90.5	97.5	7.1	TE3300800	82.14 x 3.53
85.0	95.5	102.5	7.1	TE3300850	88.49 x 3.53
90.0	100.5	107.5	7.1	TE3300900	94.84 x 3.53
95.0	105.5	112.5	7.1	TE3300950	98.02 x 3.53
100.0	110.5	117.5	7.1	TE3301000	104.37 x 3.53
105.0	115.5	122.5	7.1	TE3301050	107.54 x 3.53
110.0	120.5	127.5	7.1	TE3301100	113.89 x 3.53
115.0	125.5	132.5	7.1	TE3301150	117.07 x 3.53
120.0	134.0	142.0	9.5	TE3401200	123.19 x 5.33
125.0	139.0	147.0	9.5	TE3401250	129.54 x 5.33
130.0	144.0	152.0	9.5	TE3401300	132.72 x 5.33
135.0	149.0	157.0	9.5	TE3401350	139.07 x 5.33
140.0	154.0	162.0	9.5	TE3401400	145.42 x 5.33



Shaft Dia.	Groove Dia.	Groove Dia.	Groove Width	TSS Part No.	O-Ring Dimensions
d_N f8/h9	D_1 H9	D_2 H10	L_1 +0.20		
150.0	164.0	172.0	9.5	TE3401500	158.12 x 5.33
160.0	174.0	182.0	9.5	TE3401600	164.47 x 5.33
170.0	180.0	192.0	9.5	TE3401700	177.17 x 5.33
180.0	194.0	202.0	9.5	TE3401800	183.52 x 5.33
190.0	204.0	212.0	9.5	TE3401900	196.22 x 5.33
200.0	214.0	222.0	9.5	TE3402000	202.57 x 5.33
210.0	224.0	232.0	9.5	TE3402100	215.27 x 5.33
220.0	234.0	242.0	9.5	TE3402200	227.97 x 5.33
230.0	240.0	252.0	9.5	TE3402300	234.32 x 5.33
240.0	254.0	262.0	9.5	TE3402400	247.02 x 5.33
250.0	264.0	272.0	9.5	TE3402500	253.37 x 5.33
280.0	294.0	302.0	9.5	TE3402800	291.47 x 5.33
300.0	314.0	322.0	9.5	TE3403000	304.17 x 5.33
320.0	334.0	342.0	9.5	TE3403200	329.57 x 5.33
350.0	364.0	372.0	9.5	TE3403500	354.97 x 5.33
360.0	374.0	382.0	9.5	TE3403600	365.00 x 5.30
400.0	418.0	428.0	12.2	TE3504000	405.26 x 7.00
500.0	518.0	528.0	12.2	TE3505000	506.86 x 7.00
600.0	618.0	628.0	12.2	TE3506000	608.08 x 7.00
700.0	722.0	734.0	15.0	TE3607000	703.90 x 8.40*
800.0	822.0	834.0	15.0	TE3608000	803.90 x 8.40*
900.0	922.0	934.0	15.0	TE3609000	903.90 x 8.40*
1,000	1,022.0	1,034.0	15.0	TE36X1000	1,003.90 x 8.40*
1,500	1,522.0	1,534.0	15.0	TE36X1500	1,503.90 x 8.40*
2,000	2,022.0	2,034.0	15.0	TE36X2000	2,003.90 x 8.40*
2,200	2,222.0	2,234.0	15.0	TE36X2200	2,206.90 x 8.40*
2,600	2,622.0	2,634.0	15.0	TE36X2600	2,606.90 x 8.40*

The Shaft diameters in **bold** type correspond to the recommendations of ISO 3320.
 Other dimensions and all intermediate sizes up to 2,600 mm diameter including imperial (inch) sizes can be supplied.
 * Theoretical ideal O-Ring size



■ Installation Recommendation for Bore

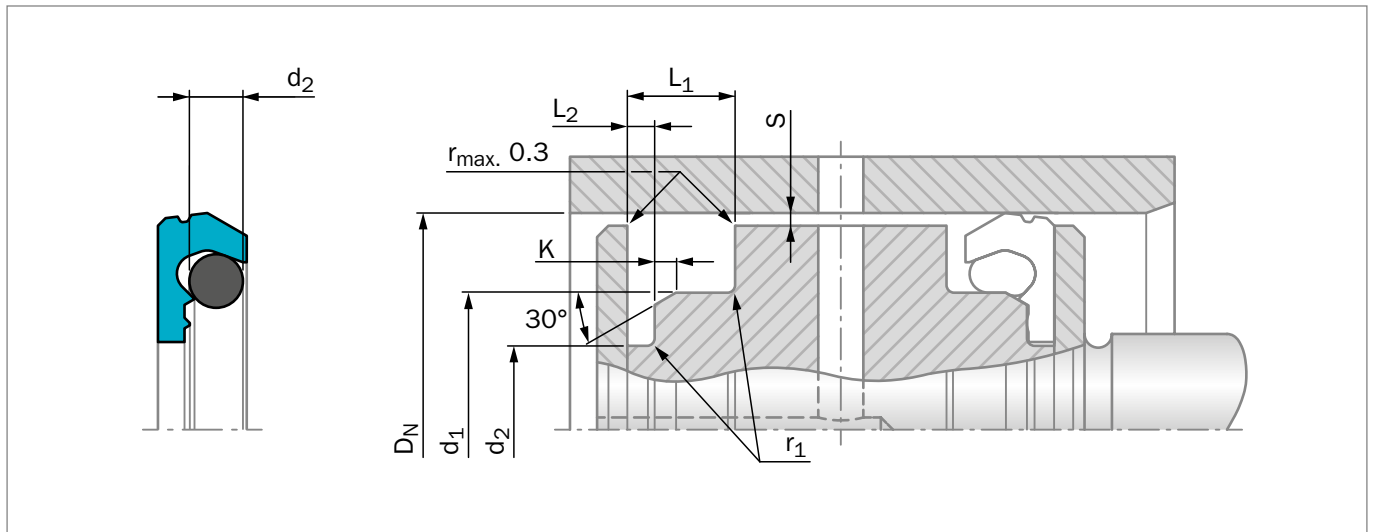

Figure 146: Installation Drawing

Table 102: Installation Dimensions – Standard Recommendations

Series Number	Bore Diameter		Groove Diameter		Groove Width		Lead-in Chamfer	Radius	Radial Clearance S_{max}^*			O-Ring Cross-Section-Ø		
	D_N H9		d_1 h9	d_2 H10	L_1 min	L_2			k	r_1	10 MPa		20 MPa	30 MPa
	Recommended Range	Available Range												
TE410	18 - 24.9	14 - 100.0	$D_N - 5.0$	$D_N - 9.0$	3.6	0.85 +0/-0.10	0.80	0.3	0.20	0.15	-	1.78		
TE420	25 - 45.9	16 - 200.0	$D_N - 7.0$	$D_N - 12.5$	4.8	1.35 +0/-0.15	1.10	0.4	0.25	0.20	0.15	2.62		
TE430	46 - 124.9	28 - 400.0	$D_N - 10.5$	$D_N - 17.5$	7.1	1.80 +0/-0.20	1.40	0.5	0.30	0.25	0.20	3.53		
TE440	125 - 399.9	45 - 650.0	$D_N - 14.0$	$D_N - 22.0$	9.5	2.80 +0/-0.20	1.60	0.5	0.35	0.30	0.25	5.33		
TE450	400 - 649.9	125 - 999.9	$D_N - 18.0$	$D_N - 22.0$	12.2	3.50 +0/-0.20	2.0	0.8	0.40	0.35	0.30	7.00		
TE460	650 - 999.9	400 - 999.9	$D_N - 22.0$	$D_N - 34.0$	15.0	4.30 +0/-0.20	2.50	1.0	0.45	0.40	0.35	8.40		
TE46X	1,000 - 2,700	-	$D_N - 22.0$	$D_N - 34.0$	15.0	4.30 +0/-0.20	2.50	1.0	0.45	0.40	0.35	8.40		

* At pressures > 30 MPa: Use diameter tolerance H8/f8 (bore / shaft) in area of seal.

ORDERING EXAMPLE

Turcon® Roto VL Seal® F complete with O-Ring, standard application:

Series:	TE440 (from page Table 102)
Bore diameter:	$D_N = 250.0$ mm
TSS Part No.:	TE4402500 (from page Table 103)

Select the material from page Table 99. The corresponding code numbers are appended to the TSS Part No. Together they form the TSS Article No. The TSS Article No. for all intermediate sizes not shown in page Table 103 can be determined following the example opposite.

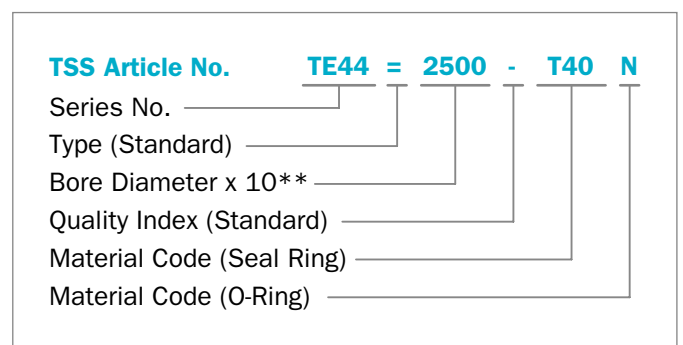

** For diameters $D_N \geq 1,000.0$ mm multiply only by factor 1.
 Example: TE46X for diameter $D_N = 1,200.0$ mm
 TSS Article No.: TE46X1200-T40N



Table 103: Standard Installation Dimensions / TSS Part Number

Bore Dia.	Groove Dia.	Groove Dia.	Groove Width	TSS Part No.	O-Ring Dimensions
D _N H9	d ₁ h9	d ₂ h10	L ₁ +0.20		
14.0	9.0	5.0	3.6	TE4100140	9.25 x 1.78
15.0	10.0	6.0	3.6	TE4100150	9.50 x 1.80
16.0	11.0	7.0	3.6	TE4100160	11.20 x 1.80
18.0	13.0	9.0	3.6	TE4100180	13.20 x 1.80
20.0	15.0	11.0	3.6	TE4100200	15.60 x 1.78
22.0	17.0	13.0	3.6	TE4100220	17.17 x 1.78
25.0	18.8	12.5	4.8	TE4200250	18.00 x 2.65
28.0	21.0	15.5	4.8	TE4200280	21.89 x 2.62
30.0	23.0	17.5	4.8	TE4200300	23.47 x 2.62
32.0	25.0	19.5	4.8	TE4200320	25.07 x 2.62
35.0	28.0	22.5	4.8	TE4200350	28.24 x 2.62
40.0	33.0	27.5	4.8	TE4200400	32.99 x 2.62
42.0	35.0	29.5	4.8	TE4200420	34.59 x 2.62
45.0	38.0	32.5	4.8	TE4200450	37.77 x 2.62
48.0	37.5	30.5	7.1	TE4300480	37.69 x 3.53
50.0	39.5	32.5	7.1	TE4300500	40.87 x 3.53
52.0	41.5	34.5	7.1	TE4300520	40.87 x 3.53
55.0	44.5	37.5	7.1	TE4300550	44.04 x 3.53
56.0	45.5	38.5	7.1	TE4300560	44.04 x 3.53
60.0	49.5	42.5	7.1	TE4300600	50.39 x 3.53
63.0	52.5	45.5	7.1	TE4300630	53.57 x 3.53
65.0	54.5	47.5	7.1	TE4300650	53.57 x 3.53
70.0	59.5	52.5	7.1	TE4300700	59.92 x 3.53
75.0	64.5	57.5	7.1	TE4300750	66.27 x 3.53
80.0	69.5	62.5	7.1	TE4300800	69.44 x 3.53
85.0	74.5	67.5	7.1	TE4300850	75.79 x 3.53
90.0	79.5	72.5	7.1	TE4300900	78.97 x 3.53
95.0	84.5	77.5	7.1	TE4300950	85.32 x 3.53
100.0	89.5	82.5	7.1	TE4301000	91.67 x 3.53
110.0	99.5	92.5	7.1	TE4301100	101.19 x 3.53
115.0	104.5	97.5	7.1	TE4301150	104.37 x 3.53
120.0	109.5	102.5	7.1	TE4301200	110.72 x 3.53
125.0	111.0	103.0	9.5	TE4401250	113.67 x 5.33
130.0	116.0	108.0	9.5	TE4401300	116.84 x 5.33
135.0	121.0	113.0	9.5	TE440135	123.19 x 5.33
140.0	126.0	118.0	9.5	TE440140	126.37 x 5.33
150.0	136.0	128.0	9.5	TE440150	135.89 x 5.33
160.0	146.0	138.0	9.5	TE440160	145.42 x 5.33
170.0	156.0	148.0	9.5	TE440170	158.12 x 5.33
180.0	166.0	158.0	9.5	TE440180	164.47 x 5.33
190.0	176.0	168.0	9.5	TE440190	177.17 x 5.33
200.0	186.0	178.0	9.5	TE440200	189.87 x 5.33



Bore Dia.	Groove Dia.	Groove Dia.	Groove Width	TSS Part No.	O-Ring Dimensions
D_N H9	d_1 h9	d_2 h10	L_1 +0.20		
210.0	196.0	188.0	9.5	TE440210	196.22 x 5.33
220.0	206.0	198.0	9.5	TE440220	208.92 x 5.33
230.0	216.0	208.0	9.5	TE440230	215.27 x 5.33
240.0	226.0	218.0	9.5	TE440240	227.97 x 5.33
250.0	236.0	228.0	9.5	TE440250	234.32 x 5.33
280.0	266.0	258.0	9.5	TE440280	266.07 x 5.33
300.0	286.0	278.0	9.5	TE440300	291.47 x 5.33
320.0	306.0	298.0	9.5	TE440320	304.17 x 5.33
350.0	336.0	328.0	9.5	TE440350	329.57 x 5.33
400.0	382.0	378.0	12.2	TE450400	380.37 x 7.00
420.0	402.0	398.0	12.2	TE450420	405.26 x 7.00
450.0	432.0	428.0	12.2	TE450450	430.66 x 7.00
480.0	462.0	458.0	12.2	TE450480	468.76 x 7.00
500.0	482.0	478.0	12.2	TE450500	481.38 x 7.00
550.0	532.0	522.0	12.2	TE4505500	532.26 x 7.00
600.0	582.0	578.0	12.2	TE450600	582.68 x 7.00
700.0	678.0	666.0	15.0	TE460700	679.30 x 8.40*
800.0	778.0	766.0	15.0	TE460800	779.30 x 8.40*
900.0	878.0	866.0	15.0	TE460900	879.30 x 8.40*
1,000.0	978.0	966.0	15.0	TE46X1000	979.30 x 8.40*
1,500.0	1,478.0	1,466.0	15.0	TE46X1500	1,479.30 x 8.40*
2,000.0	1,978.0	1,966.0	15.0	TE46X2000	1,979.30 x 8.40*
2,200.0	2,178.0	2,166.0	15.0	TE46X2200	2,173.30 x 8.40*
2,700.0	2,678.0	2,666.0	15.0	TE46X2700	2,676.30 x 8.40*

The Shaft diameters in **bold** type correspond to the recommendations of ISO 3320.

Other dimensions and all intermediate sizes up to 2,700 mm diameter including imperial (inch) sizes can be supplied.

* Theoretical ideal O-Ring size



Turcon[®] Roto VL Seal[®]







■ Turcon® Roto VL Seal®

■ Description

Turcon® Roto VL Seal® is a single-acting rotary seal with the same groove dimensions as standard O-Rings (see Figure 147).

The design is optimised for, friction, leakage and service life.

Roto VL Seal® offer improved performance in terms of high dynamic seal efficiency, low friction and static sealing by an elastomer component.

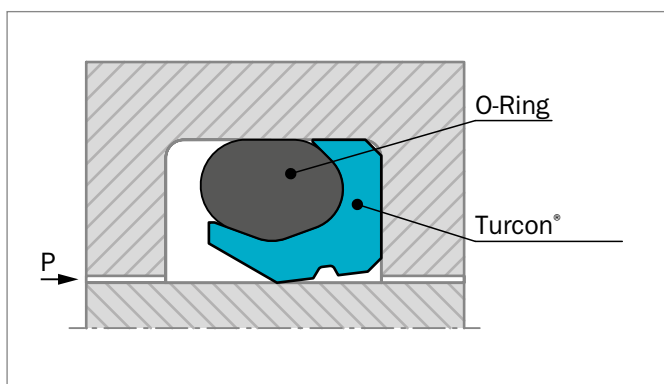

Figure 147: Turcon® Roto VL Seal®

Roto VL Seal® covers both shaft and bore installations.

The single acting Roto VL Seal® is a combination of a Turcon® based slipper seal and an energizing O-Ring. It has an interference fit which together with the squeeze of the O-Ring ensures a good sealing effect even at low pressure. At higher system pressures the O-Ring is energized by the fluid pushing Roto VL Seal® against the sealing face with increased force.

Roto VL Seal® has very high static sealing effect in the groove provided by the O-Ring, which is protected from damage under pressure cycles by the supporting concave seal back and keeps it in position also at high working pressure.

ADVANTAGES

- Standard O-Ring groove dimensions, ISO 6194 and AS 4716
- For rotary, turning and helical movements
- Low to high pressure
- Low friction
- Stick-slip-free starting, no sticking

- High static sealing effect
- High dimensional stability
- Lubricant reservoir
- Available in Turcon® and Zurcon® materials
- Available in most materials and in all sizes up to 2,600 mm for shaft seals and to 2,700 mm for bore seals

APPLICATIONS EXAMPLES

The seal is used in hydraulics and general machine construction as an alternative to other single-acting seals according to their individual advantages in:

- Rolling Mills: Bearing Grease Seals
- Tool Machine Industry, mainly Machining Centres
- Hydraulic Swivels
- Injection Molding Machines: Rotary Injection Unit
- Valve Spindles
- Food Processing: Blender and Mixers
- Hydraulic Steering Units
- Hydraulic Rotator: Forest machines
- Rotator for Handling Devices
- Vane Actuators / Motors
- Hydraulic Motors
- Hydraulic Pumps
- Propeller Thrusters
- ROV (Remotely Operated Vehicle)

OPERATING CONDITIONS

Seal performance is influenced by such factors as lubrication capability of the sealed medium and heat dissipation in the hardware. Therefore testing should always be carried out. With good lubrication, the following values can be used:

Movement:	Rotary and oscillating or helical
Pressure:	Up to 30 MPa at slow turning motion 20 MPa recommended max. at continuous rotation
Speed:	Up to 2 m/s and/or 1000 rpm according to seal material



Temperature:	Turcon® materials: -40 to +120 °C *) (+150 °C at slow turning) according to O-Ring material
	Zurcon® Z52: -40 to +80 °C *) (+100 °C at slow turning) according to O-Ring material
	Zurcon® Z80: -40 to +60 °C *) (+80 °C at slow turning) according to O-Ring material
Media:	Mineral oil-based hydraulic fluids, flame-retardant hydraulic fluids, environmentally friendly hydraulic fluids (bio-oils), water and others, depending on seal and elastomer material.
Availability:	Shaft diameters from 6 to 2,600 mm (2,200 for Zurcon® Z54)
	Bore diameters from 10 to 2,700 mm (2,300 for Zurcon® Z54)
Caution with:	Operating at temperatures above +80 °C, use O-Rings in HNBR or FKM
	Rotary service on shafts and bores with poor heat dissipation
	Shaft and bores with hardness below 50 HRC
	Constant rotation for Zurcon® materials

IMPORTANT NOTE

The above data are maximum values and cannot be used at the same time, e. g. the maximum operating speed depends on material type, pressure, temperature and gap value.

*) IMPORTANT NOTE FOR BORE VERSION:

In the case on unpressurized applications in temperatures below 0 °C please contact your local Trelleborg Sealing Solutions marketing company for more information.

RADIAL NOTCH

Turcon® Roto VL Seal® can be delivered with radial notches on the “back side” (low pressure side). This is an advantage if the seal is used in rotary applications. If pressurized fluid is trapped between the seal and groove corner, notches can prevent the seal from rotating in the groove. (See ordering examples).

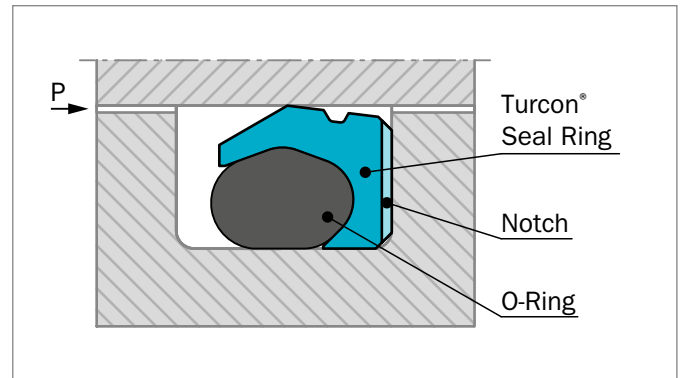

Figure 148: Turcon® Roto VL Seal® with radial notch

FRICIONAL POWER

Guide values for the frictional power (P) can be determined from the graph in Figure 149. They are shown as a function of the sliding speed and operating pressure for a shaft diameter of 50 mm with an oil temperature of +60 °C. At higher temperatures, these application limits must be reduced.

Formula for other diameters d:

$$P = \frac{P_{50} \times (d)}{(50 \text{ mm})} \text{ [W]}$$

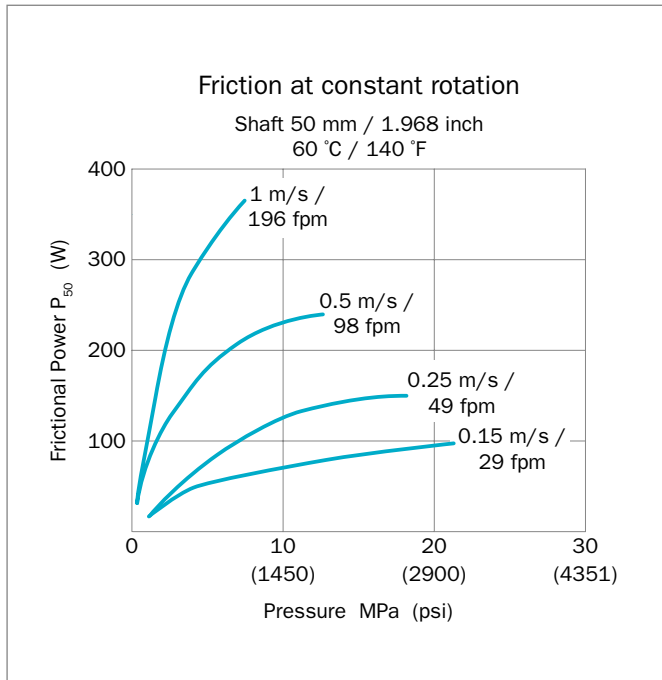

Figure 149: Frictional power for Turcon® Roto VL Seal®

The guide values apply for constant operating conditions. Pressure fluctuations or alternating directions of shaft rotation can result in considerably higher friction values.

INSTALLATION INSTRUCTIONS

Roto VL Seal® is installed according to information at page 309.

Closed groove installation according to dimensions at Table 105 on page 302.

O-RING SIZE

O-Rings for Roto VL Seal® are selected to suit the groove diameter.

For shaft seals the O-Ring should have OD equal to or smaller than groove diameter, for bore seals the O-Ring should have ID equal to or smaller than groove diameter.

RECOMMENDED MATERIALS

The following material combinations have proven effective for rotary applications:

Turcon Roto VL Seal® in Turcon® T40

All-round material choice in oil hydraulics, water and other fluids with limited lubrication:

O-Ring:	NBR 70 Shore A	N
	FKM 70 Shore A	V
	HNBR 70 Shore A	H

Set code: T40N, T40V or T40H

Turcon Roto VL Seal® in Turcon® in M15

Material with high sealing effect for light to medium applications in fluids with good lubrication:

O-Ring:	NBR 70 Shore A	N
	FKM 70 Shore A	V
	HNBR 70 Shore A	H

Set code: M15N, M15V or M15H

Turcon Roto VL Seal® in Zurcon® in Z80

For slow turning applications fluid, with air, gases and/or risk of high abrasive wear.

Temperature limit -45 °C to +80 °C:

O-Ring:	NBR 70 Shore A	N
	FKM 70 Shore A	V
	(according to media)	

Set code: Z80N or Z80V

Z80 is not for constant rotation.

For specific applications other Turcon® and Zurcon® materials are available.



Table 104: Turcon® and Zurcon® Materials

Material, Applications, Properties	Code	O-Ring Material Shore A	Code	O-Ring Operating Temp.* °C	Mating Surface Material	MPa max. Dynamic
Turcon® M12 For lubricated applications High compressive strength Low friction Tight surface texture High sealing effect Good sliding properties Good extrusion resistance Mineral fiber and additives filled Color: Dark green-gray	M12	NBR 70	N	-30 to +100	Steel hardened	15
		NBR 70 Low temp.	T	-45 to +80	Steel, chrome plated (shaft)	
		FKM 70	V	-10 to +200	Cast iron	
		HNBR 70	H	-30 to +150		
Turcon® M15 For lubricating fluids Excellent for rotary service High sealing effect Very good wear properties Low friction Polyaramid, mineral fiber, lubricant and graphite filled Color: Dark gray	M15	NBR 70	N	-30 to +100	Steel hardened	25
		NBR 70 Low temp.	T	-45 to +80	Steel chrome plated (shaft)	
		FKM 70	V	-10 to +200	Cast iron	
		HNBR 70	H	-30 to +150		
Turcon® M40 All round material for rotary and turning movements For lubricating fluids and fluids with low lubricating properties, e.g. water Surface texture not suitable for gases Carbon fiber filled Color: Gray	T40	NBR 70	N	-30 to +100	Steel	30
		NBR 70 Low temp.	T	-45 to +80	Steel chrome plated (shaft)	
		FKM 70	V	-10 to +200	Cast iron	
		HNBR 70	H	-30 to +150	Stainless steel Hard Alloys	
Zurcon® Z54** For lubricated applications with rougher counter surface finish High abrasion resistance Not for constant rotation Max. working temperature +110 °C Cast polyurethane Color: Turquoise	Z54	NBR 70	N	-30 to +100	Steel hardened	20
		NBR 70 Low temp.	T	-45 to +80	Steel, chrome plated (shaft) Stainless steel Ceramic coating	

Table is continued on next page



Material, Applications, Properties	Code	O-Ring Material Shore A	Code	O-Ring Operating Temp.* °C	Mating Surface Material	MPa max. Dynamic
Zurcon® Z80 For lubricating fluids and fluids with low lubricating properties***, water, air and gases at low pressure Good abrasion resistance Good chemical resistance Not for constant rotation Max. working temperature +80 °C Ultra high molecular weight polyethylene Color: White to off-white	Z80	NBR 70	N	-30 to +80	Steel hardened	20
		NBR 70 Low temp.	T	-45 to +80	Steel chrome plated (shaft)	
		FKM 70	V	-10 to +80	Stainless steel Ceramic coating	

* The O-Ring operation temperature is only valid in mineral hydraulic oil.

** max. \varnothing 2,200 mm.

*** E.g. coolant fluids

Highlighted materials are recommended.



■ Installation Recommendation for Shaft

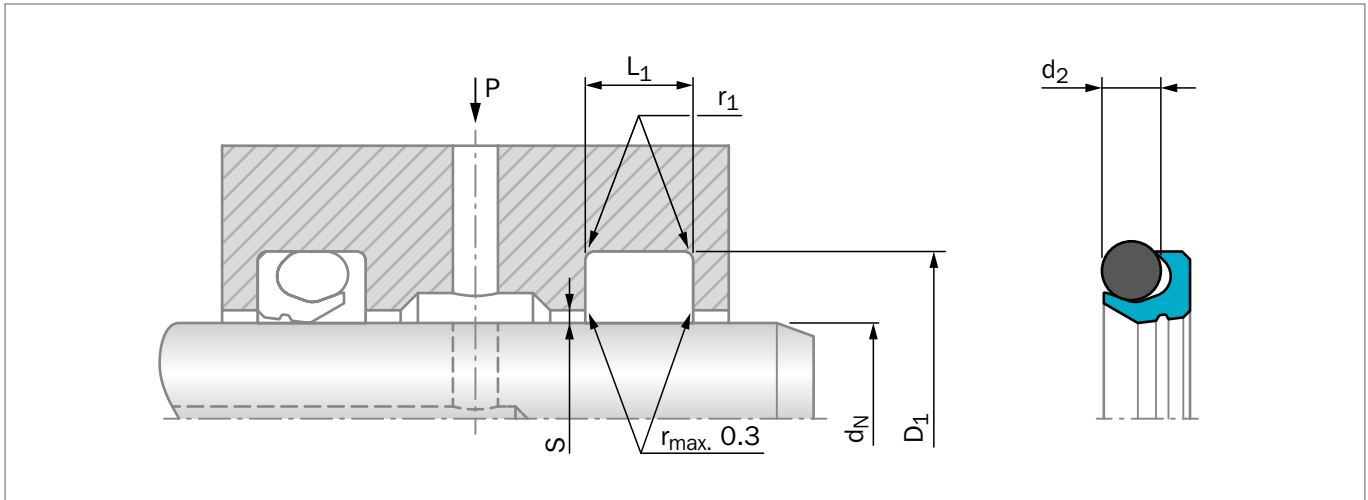

Figure 150: Installation Drawing

Table 105: Installation Dimensions – Standard Recommendations

Series Number	Shaft Diameter d_N f8/h9		Groove Diameter D_1 H9	Groove Width $L_1 + 0.2$	Radius r_1	Radial Clearance S_{max}^*			O-Ring Cross-Section- ϕ d_2	No. of grooves in the Sealing Surface
	Recommended Range	Available Range				10 MPa	20 MPa	30 MPa		
TE110	10 - 19.9	6 - 100.0	$d_N + 4.5$	3.6	0.4	0.20	0.15	-	1.78	0
TE120	20 - 39.9	10 - 200.0	$d_N + 6.2$	4.8	0.6	0.25	0.20	0.15	2.62	1
TE130	40 - 119.9	20 - 400.0	$d_N + 9.4$	7.1	0.8	0.30	0.25	0.20	3.53	1
TE140	120 - 399.9	35 - 650.0	$d_N + 12.2$	9.5	0.8	0.35	0.30	0.25	5.33	2
TE150	400 - 649.9	125 - 999.9	$d_N + 15.9$	12.2	0.8	0.40	0.35	0.30	7.00	2
TE160	650 - 999.9	400 - 999.9	$d_N + 19.0$	15.0	0.8	0.45	0.40	0.35	8.40	2
TE16X	1,000 - 2,600	-	$d_N + 19.0$	15.0	0.8	0.45	0.40	0.35	8.40	2

* At pressures > 30 MPa: Use diameter tolerance H8/f8 (bore / shaft) in area of seal.

ORDERING EXAMPLE

Roto VL Seal® complete with O-Ring, standard application:

Series: TE130 (from Table 105)
Shaft diameter: $d_N = 75.0$ mm
TSS Part No.: TE1300750 (from Table 106)

Select the material from Table 104. The corresponding code numbers are appended to the TSS Part No. Together they form the TSS Article No. The TSS Article No. for all intermediate sizes not shown in Table 106 can be determined following the example opposite.

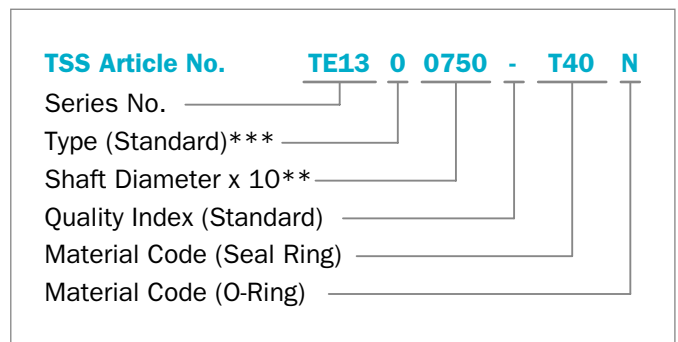

** For diameters $\geq 1,000.0$ mm multiply only by factor 1.
 Example: TE16X for diameter 1,200.0 mm
 TSS Article No.: TE16X1200-T40N

*** Use suffix "N" for seals with radial notches, for diameter $d_N < 1,000$ mm (Figure 148).
 (Radial notches for diameter $d_N \geq 1,000$ mm TSS Special Article Number is required).



Table 106: Standard Installation Dimensions / TSS Part Number

Shaft Dia.	Groove Dia.	Groove Width	TSS Part No.	O-Ring Dimensions	Shaft Dia.	Groove Dia.	Groove Width	TSS Part No.	O-Ring Dimensions
d_N f8/h9	D_1 H9	L_1 +0.20			d_N f8/h9	D_1 H9	L_1 +0.20		
6.0	10.5	3.6	TE1100060	7.10 x 1.80	150.0	162.2	9.5	TE1401500	158.12 x 5.33
8.0	12.5	3.6	TE1100080	9.25 x 1.78	160.0	172.2	9.5	TE1401600	164.47 x 5.33
10.0	14.5	3.6	TE1100100	11.20 x 1.80	170.0	182.2	9.5	TE1401700	177.17 x 5.33
12.0	16.5	3.6	TE1100120	13.20 x 1.80	180.0	192.2	9.5	TE1401800	183.52 x 5.33
14.0	18.5	3.6	TE1100140	15.60 x 1.78	190.0	202.2	9.5	TE1401900	196.22 x 5.33
15.0	19.5	3.6	TE1100150	16.32 x 1.78	200.0	212.2	9.5	TE1402000	202.57 x 5.33
16.0	20.5	3.6	TE1100160	17.17 x 1.78	210.0	222.2	9.5	TE1402100	215.27 x 5.33
18.0	22.5	3.6	TE1100180	19.00 x 1.80	220.0	232.2	9.5	TE1402200	227.97 x 5.33
20.0	26.2	4.8	TE1200200	21.89 x 2.62	230.0	242.2	9.5	TE1402300	234.32 x 5.33
22.0	28.2	4.8	TE1200220	23.47 x 2.62	240.0	252.2	9.5	TE1402400	247.02 x 5.33
25.0	31.2	4.8	TE120025	26.64 x 2.62	250.0	262.2	9.5	TE1402500	253.37 x 5.33
28.0	34.2	4.8	TE1200280	29.82 x 2.62	280.0	292.2	9.5	TE1402800	291.47 x 5.33
30.0	36.2	4.8	TE1200300	31.42 x 2.62	300.0	312.2	9.5	TE1403000	304.17 x 5.33
32.0	38.2	4.8	TE1200320	34.59 x 2.62	320.0	332.2	9.5	TE1403200	329.57 x 5.33
35.0	41.2	4.8	TE1200350	36.17 x 2.62	350.0	362.2	9.5	TE1403500	354.97 x 5.33
36.0	42.2	4.8	TE1200360	37.77 x 2.62	360.0	372.2	9.5	TE1403600	365.00 x 5.30
40.0	49.4	7.1	TE1300400	44.04 x 3.53	400.0	415.9	12.2	TE1504000	405.26 x 7.00
42.0	51.4	7.1	TE1300420	44.04 x 3.53	500.0	515.9	12.2	TE1505000	506.86 x 7.00
45.0	54.4	7.1	TE1300450	47.22 x 3.53	600.0	615.9	12.2	TE1506000	608.08 x 7.00
48.0	57.4	7.1	TE1300480	50.39 x 3.53	700.0	719.0	15.0	TE1607000	703.90 x 8.40*
50.0	59.4	7.1	TE1300500	53.57 x 3.53	800.0	819.0	15.0	TE1608000	803.90 x 8.40*
52.0	61.4	7.1	TE1300520	56.74 x 3.53	900.0	919.0	15.0	TE1609000	903.90 x 8.40*
55.0	64.4	7.1	TE1300550	59.92 x 3.53	1,000.0	1,019.0	15.0	TE16X1000	1,003.90 x 8.40*
56.0	65.4	7.1	TE1300560	59.92 x 3.53	1,500.0	1,519.0	15.0	TE16X1500	1,503.90 x 8.40*
60.0	69.4	7.1	TE1300600	63.09 x 3.53	2,000.0	2,019.0	15.0	TE16X2000	2,003.90 x 8.40*
63.0	72.4	7.1	TE1300630	66.27 x 3.53	2,200.0	2,219.0	15.0	TE16X2200	2,203.90 x 8.40*
65.0	74.4	7.1	TE1300650	69.44 x 3.53	2,600.0	2,619.0	15.0	TE16X2600	2,603.90 x 8.40*
70.0	79.4	7.1	TE1300700	72.62 x 3.53	The shaft diameters in bold type correspond to the recommendations of ISO 3320.				
75.0	84.4	7.1	TE1300750	78.97 x 3.53					
80.0	89.4	7.1	TE1300800	82.14 x 3.53	Other dimensions and all intermediate sizes up to 2,600 mm diameter including imperial (inch) sizes can be supplied.				
85.0	94.4	7.1	TE1300850	88.49 x 3.53					
90.0	99.4	7.1	TE1300900	94.84 x 3.53	* Theoretical ideal O-Ring size				
95.0	104.4	7.1	TE1300950	98.02 x 3.53					
100.0	109.4	7.1	TE1301000	104.37 x 3.53					
105.0	114.4	7.1	TE1301050	107.54 x 3.53					
110.0	119.4	7.1	TE1301100	113.89 x 3.53					
115.0	124.4	7.1	TE1301150	117.07 x 3.53					
120.0	132.2	9.5	TE1401200	123.19 x 5.33					
125.0	137.2	9.5	TE1401250	129.54 x 5.33					
130.0	142.2	9.5	TE1401300	132.72 x 5.33					
135.0	147.2	9.5	TE1401350	139.07 x 5.33					
140.0	152.2	9.5	TE1401400	145.42 x 5.33					



■ Installation Recommendation for Bore

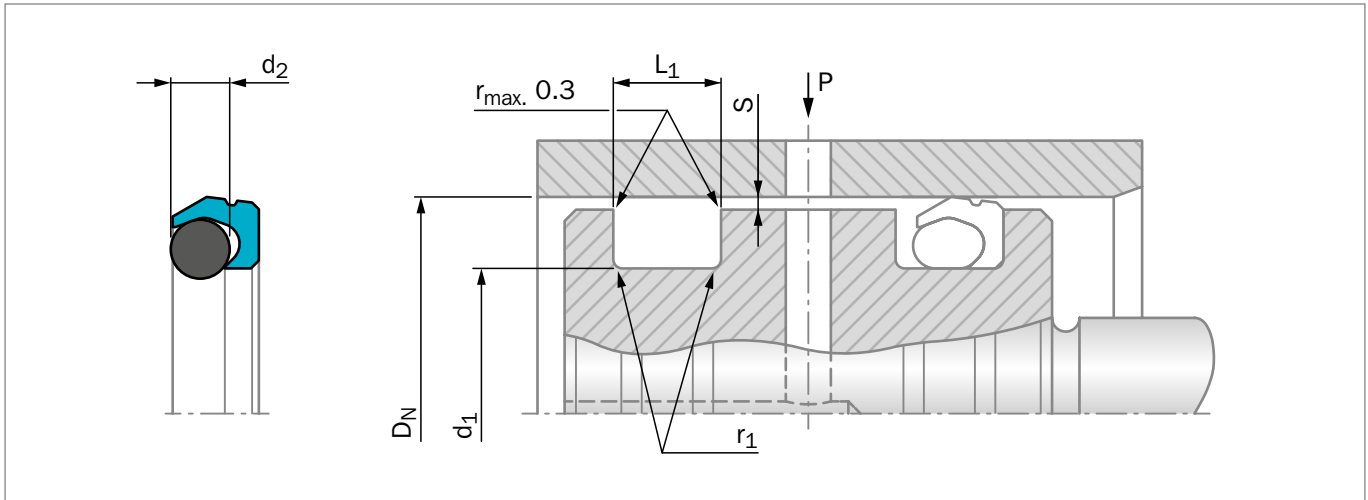

Figure 151: Installation Drawing

Table 107: Installation Dimensions – Standard Recommendations

Series Number	Bore Diameter D_N H9		Groove Diameter d_1 h9	Groove Width $L_1 + 0.2$	Radius r_1	Radial Clearance S_{max}^*			O-Ring Cross-Section- \emptyset d_2
	Recommended Range	Available Range				10 MPa	20 MPa	30 MPa	
TE210	14 - 24.9	10 - 100.0	$D_N - 4.5$	3.6	0.4	0.20	0.15	-	1.78
TE220	25 - 45.9	16 - 200.0	$D_N - 6.2$	4.8	0.6	0.25	0.20	0.15	2.62
TE230	46 - 124.9	28 - 400.0	$D_N - 9.4$	7.1	0.8	0.30	0.25	0.20	3.53
TE240	125 - 399.9	45 - 650.0	$D_N - 12.2$	9.5	0.8	0.35	0.30	0.25	5.33
TE250	400 - 649.9	125 - 999.9	$D_N - 15.9$	12.2	0.8	0.40	0.35	0.30	7.00
TE260	650 - 999.9	400 - 999.9	$D_N - 19.0$	15.0	0.8	0.45	0.40	0.35	8.40
TE26X	1,000 - 2,700	-	$D_N - 19.0$	15.0	0.8	0.45	0.40	0.35	8.40

* At pressures > 30 MPa: Use diameter tolerance H8/f8 (bore / shaft) in area of seal.

ORDERING EXAMPLE

Roto VL Seal® complete with O-Ring, standard application:

Series: TE240 (from Table 107)

Bore diameter: $D_N = 250.0$ mm

TSS Part No.: TE2402500 (from Table 108)

Select the material from Table 104. The corresponding code numbers are appended to the TSS Part No. Together they form the TSS Article No. The TSS Article No. for all intermediate sizes not shown in Table 108 can be determined following the example opposite.

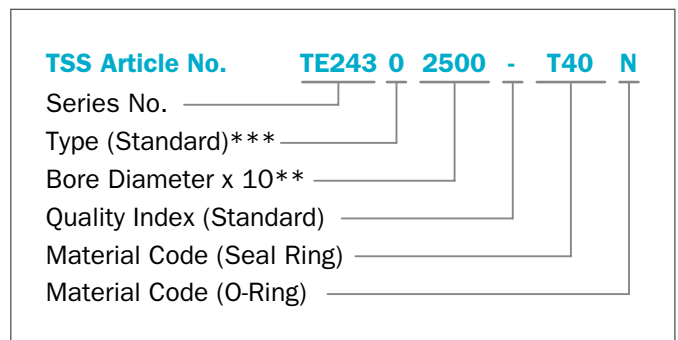

** For diameters $\geq 1,000.0$ mm multiply only by factor 1.

Example: TE26X for diameter $D_N = 1,200.0$ mm

TSS Article No.: TE26X1200-T40N

*** Use suffix "N" for seals with radial notches, for diameter $D_N < 1,000$ mm (Figure 148).

(Radial notches for diameter $D_N \geq 1,000$ mm TSS Special Article Number is required).



Table 108: Standard Installation Dimensions / TSS Part Number

Bore Dia.	Groove Dia.	Groove Width	TSS Part No.	O-Ring Dimension	Bore Dia.	Groove Dia.	Groove Width	TSS Part No.	O-Ring Dimension
D_N f8/h9	d_1 H9	L_1 +0.20			D_N f8/h9	d_1 H9	L_1 +0.20		
10.0	5.5	3.6	TE2100100	5.28 x 1.78	170.0	157.8	9.5	TE2401700	158.12 x 5.33
12.0	7.5	3.6	TE2100120	7.10 x 1.80	180.0	167.8	9.5	TE2401800	164.47 x 5.33
14.0	9.5	3.6	TE2100140	9.25 x 1.78	190.0	177.8	9.5	TE2401900	177.17 x 5.33
15.0	10.5	3.6	TE2100150	9.50 x 1.80	200.0	187.8	9.5	TE2402000	189.87 x 5.33
16.0	11.5	3.6	TE2100160	11.20 x 1.80	210.0	197.8	9.5	TE2402100	196.22 x 5.33
18.0	13.5	3.6	TE2100180	13.20 x 1.80	220.0	207.8	9.5	TE2402200	208.92 x 5.33
20.0	15.5	3.6	TE2100200	15.60 x 1.78	230.0	217.8	9.5	TE2402300	215.27 x 5.33
22.0	17.5	3.6	TE2100220	17.17 x 1.78	240.0	227.8	9.5	TE2402400	227.97 x 5.33
25.0	18.8	4.8	TE2200250	18.00 x 2.65	250.0	237.8	9.5	TE2402500	234.32 x 5.33
28.0	21.8	4.8	TE2200280	21.89 x 2.62	280.0	267.8	9.5	TE2402800	266.07 x 5.33
30.0	23.8	4.8	TE2200300	23.47 x 2.62	300.0	287.8	9.5	TE2403000	291.47 x 5.33
32.0	25.8	4.8	TE2200320	25.07 x 2.62	320.0	307.8	9.5	TE2403200	304.17 x 5.33
35.0	28.8	4.8	TE2200350	28.24 x 2.62	350.0	337.8	9.5	TE2403500	329.57 x 5.33
40.0	33.8	4.8	TE2200400	32.99 x 2.62	400.0	384.1	12.2	TE2504000	380.37 x 7.00
42.0	35.8	4.8	TE2200420	34.59 x 2.62	420.0	404.1	12.2	TE2504200	405.26 x 7.00
45.0	38.8	4.8	TE2200450	37.77 x 2.62	450.0	434.1	12.2	TE2504500	430.66 x 7.00
48.0	38.6	7.1	TE2300480	37.69 x 3.53	480.0	464.1	12.2	TE2504800	468.76 x 7.00
50.0	40.6	7.1	TE2300500	40.87 x 3.53	500.0	484.1	12.2	TE2505000	481.38 x 7.00
52.0	42.6	7.1	TE2300520	40.87 x 3.53	600.0	584.1	12.2	TE2506000	582.68 x 7.00
55.0	45.6	7.1	TE2300550	44.04 x 3.53	700.0	681.0	15.0	TE2607000	679.30 x 8.40*
56.0	46.6	7.1	TE2300560	44.04 x 3.53	800.0	781.0	15.0	TE2608000	779.30 x 8.40*
60.0	50.6	7.1	TE2300600	50.39 x 3.53	900.0	881.0	15.0	TE2609000	879.30 x 8.40*
63.0	53.6	7.1	TE2300630	53.57 x 3.53	1,000.0	981.0	15.0	TE26X1000	979.30 x 8.40*
65.0	55.6	7.1	TE2300650	53.57 x 3.53	1,500.0	1,481.0	15.0	TE26X1500	1,479.30 x 8.40*
70.0	60.6	7.1	TE2300700	59.92 x 3.53	2,000.0	1,981.0	15.0	TE26X2000	1,979.30 x 8.40*
75.0	65.6	7.1	TE2300750	66.27 x 3.53	2,700.0	2,681.0	15.0	TE26X2700	2,679.30 x 8.40*
80.0	70.6	7.1	TE2300800	69.44 x 3.53	<p>The bore diameters in bold type comply with the recommendations of ISO 3320.</p> <p>Other dimensions and all intermediate sizes up to 2,700 mm diameter including imperial (inch) sizes can be supplied.</p> <p>* Theoretical ideal O-Ring size</p>				
85.0	75.6	7.1	TE2300850	75.79 x 3.53					
90.0	80.6	7.1	TE2300900	78.97 x 3.53					
95.0	85.6	7.1	TE2300950	85.32 x 3.53					
100.0	90.6	7.1	TE2301000	91.67 x 3.53					
110.0	100.6	7.1	TE2301100	101.19 x 3.53					
115.0	105.6	7.1	TE2301150	104.37 x 3.53					
120.0	110.6	7.1	TE2301200	110.72 x 3.53					
125.0	112.8	9.5	TE2401250	113.67 x 5.33					
130.0	117.8	9.5	TE2401300	116.84 x 5.33					
135.0	122.8	9.5	TE2401350	123.19 x 5.33					
140.0	127.8	9.5	TE2401400	126.37 x 5.33					
150.0	137.8	9.5	TE2401500	135.89 x 5.33					
160.0	147.8	9.5	TE2401600	145.42 x 5.33					



Turcon® Roto Seals Installation Instructions







■ Turcon® Roto Seals – Installation Instructions

■ General Description

INSTALLATION INSTRUCTIONS FOR TURCON® ROTO SEALS

The following points should be observed before installation of the seals:

- Check whether the shaft or housing have lead-in chamfers; if not, use an installation mandrel or sleeve.
- Deburr and chamfer or round sharp edges, cover the tips of any screw threads.
- Remove machining residues such as chips, dirt and other foreign particles and carefully clean all parts.
- The seals can be installed more easily if they are greased or oiled. Attention must be paid to the compatibility of the media and seal materials with these lubricants. Use only grease without solid additives (e.g. molybdenum disulfide or zinc sulfide).
- Do not use installation tools with sharp edges.

Turcon® Roto Seals are preferably installed in closed grooves. Depending on type and size installation in split grooves is also possible (see Figure 152, Figure 153 and Figure 154).

Turcon® Roto Variseal® and Turcon® Roto VL Seal® F are always installed in split grooves (see Figure 154).

INSTALLATION IN SPLIT GROOVES

Roto Glyd Ring® types and Roto VL Seal® for Shaft and Bore: Installation in split grooves is simple. The following installation sequence is recommended:

- Pull the O-Ring onto the Turcon® seal ring.
- Press the seal element into the groove. The O-ring must not be allowed to twist.

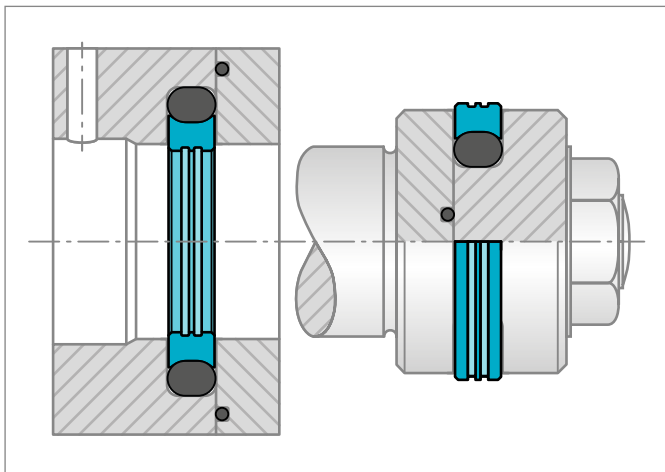

Figure 152: Installation of Roto Glyd Ring® in split groove

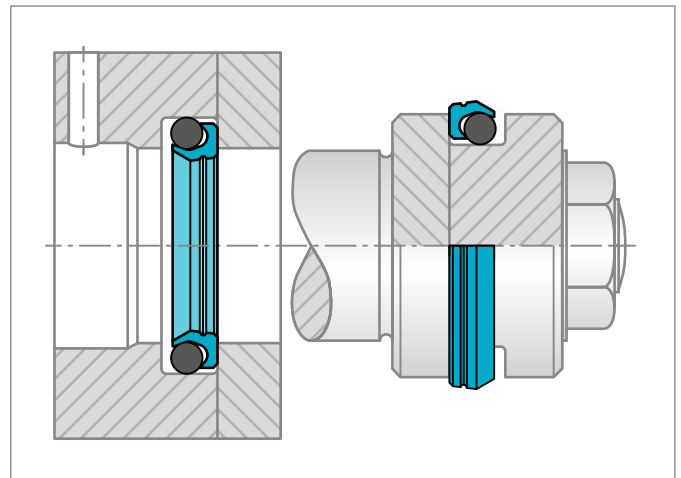

Figure 153: Installation of Roto VL Seal® in split grooves

- Calibrate the seal before the shaft is inserted.

The shaft or housing themselves can be used for this purpose, provided they have the required lead-in chamfers. Alternatively a corresponding sizing mandrel or sleeve must be used.

INSTALLATION OF TURCON® ROTO VARISEAL® AND TURCON® ROTO VL SEAL® F

Roto Variseal® and Roto VL Seal® F are dimensionally interchangeable and always installed in split grooves (see Figure 152 and Figure 154).

Installation should be performed in the following steps in order to ensure a concentric and strain-free fit:

- Pull the O-Ring on the Turcon® seal ring (only for Roto VL Seal® F).
- Place the seal into the open groove.
- Fit the cover loosely onto the housing

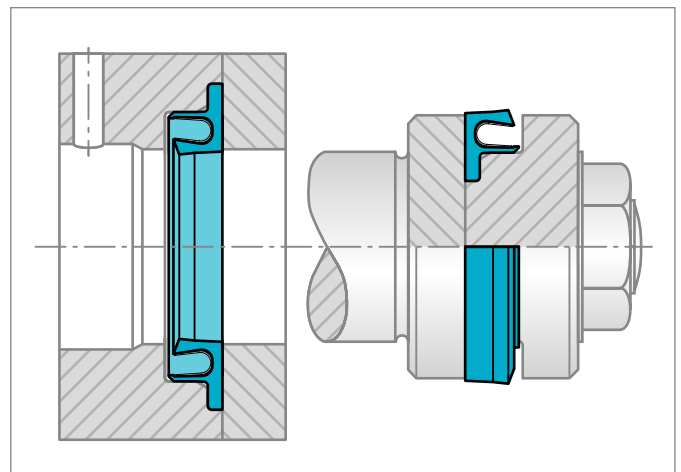

Figure 154: Installation of Variseal®

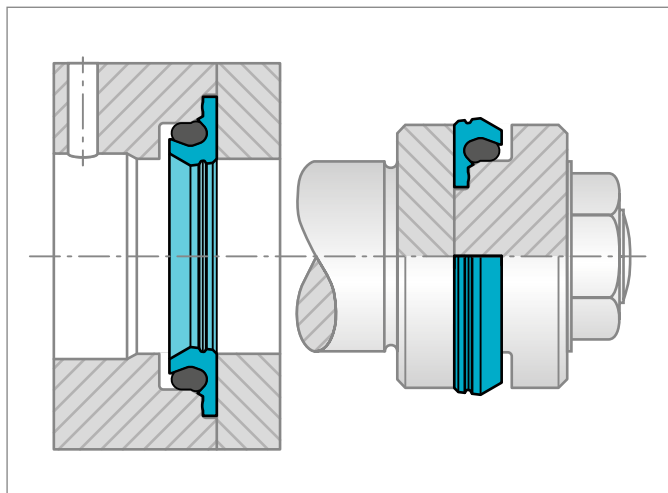

Figure 155: Installation of rod Turcon® Roto Variseal® and Roto VL Seal® F in split groove

- Insert the shaft or housing - check whether shaft or housing have the recommended lead-in chamfers; if not, use an installation mandrel or sleeve.
- Tighten the cover.

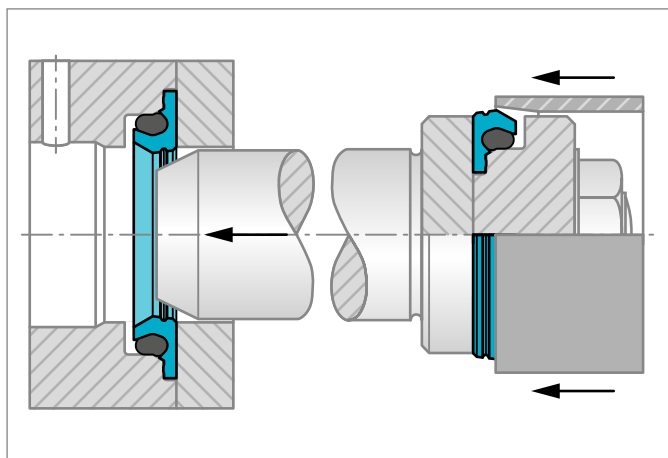

Figure 156: Installation of rod Turcon® Roto Variseal® and Roto VL Seal® F in split groove

INSTALLATION RECOMMENDATION IN CLOSED GROOVES FOR SHAFT SEALS

Installation in closed grooves is possible for diameters according to Table 109, Table 110 and Table 112.

Seal sizes for smaller diameters than stated in the Tables require split groove assembly.

CLOSED GROOVE INSTALLATION LIMITS FOR TURCON® ROTO GLYD RING® TYPE FOR SHAFT

Table 109: Closed Groove Installation Limits

Roto Glyd Ring® and Roto Glyd Ring® K		
O-Ring Series	Material	Material
	M12, M15, T40, Z54	T10, Z53, Z80
	mm	mm
000	$\varnothing d_N \geq 20$	$\varnothing d_N \geq 20$
100	$\varnothing d_N \geq 30$	$\varnothing d_N \geq 38$
200	$\varnothing d_N \geq 40$	$\varnothing d_N \geq 50$
300	$\varnothing d_N \geq 60$	$\varnothing d_N \geq 75$
400	$\varnothing d_N \geq 100$	$\varnothing d_N \geq 133$
500	$\varnothing d_N \geq 256$	$\varnothing d_N \geq 400$

Table 110: Closed Groove Installation Limits

Roto Glyd Ring® S		
Series No.	Material	Material
	Z54	Z53, Z80
	mm	mm
TG50	$\varnothing d_N \geq 12$	$\varnothing d_N \geq 12$
TG51	$\varnothing d_N \geq 16$	$\varnothing d_N \geq 19$
TG52	$\varnothing d_N \geq 19$	$\varnothing d_N \geq 25$
TG53	$\varnothing d_N \geq 38$	$\varnothing d_N \geq 50$
TG54	$\varnothing d_N \geq 70$	$\varnothing d_N \geq 90$
TG55	$\varnothing d_N \geq 256$	$\varnothing d_N \geq 400$

Table 111: Closed Groove Installation Limits

Roto Glyd Ring® V	
Series No.	Materials
	M04, M12, M15, M30, T40, Z80, Z81, Z82
	Shaft Diameter
	d_N mm
TG72	$d_N \geq 40$
TG73	$d_N \geq 60$
TG74	$d_N \geq 100$
TG75	$d_N \geq 256$



INSTALLATION PROCEDURE FOR TURCON® ROTO GLYD RING® TYPE SHAFT SEALS:

- Place the O-Ring into the groove first (avoid twisting the ring)
- Fold the Turcon® seal ring into a kidney shape (see Figure 157).
- The seal must have no sharp bends. Avoid bending the seal at the position of the notches.
- Place the folded Turcon® seal ring into the groove and push against the O-Ring.

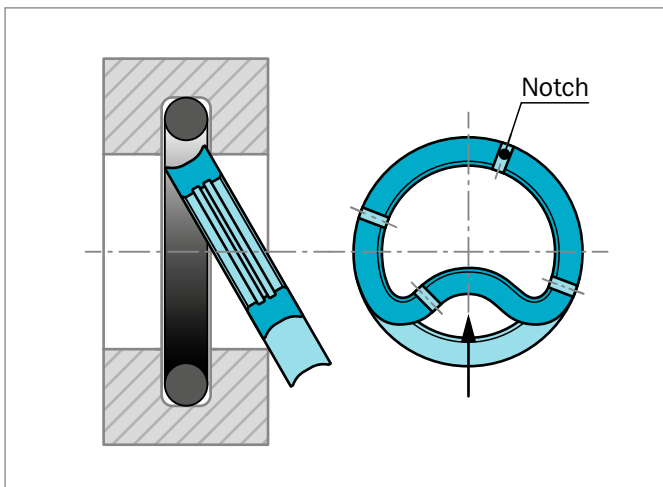

Figure 157: Installation of shaft Roto Glyd Ring® type in closed groove

- Calibrate the seal before the shaft is inserted.

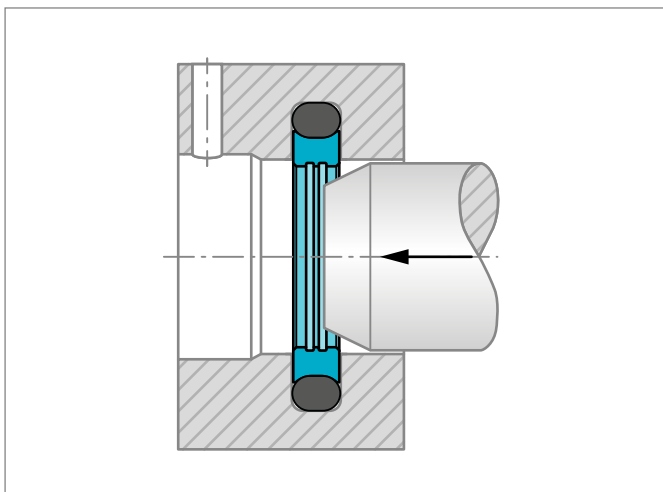

Figure 158: Calibration of installed Roto Glyd Ring®

The shaft itself can be used for sizing, provided that it has the required lead-in chamfer as per recommendations in Table 116.

Otherwise, a corresponding sizing mandrel in polymer material (e.g. POM, polyacetal) must be used.

INSTALLATION OF ROTO GLYD RING® V FOR SHAFT SEALS

As standard, Turcon® Roto Glyd Ring® V is delivered with the Quad-Ring® installed.

If ordered **without** Quad-Ring®, install the Quad-Ring® in the lubrication groove following this procedure:

- 1) To facilitate the assembly, lubricate the Quad-Ring® with the media or a lubricant compatible with the media.
- 2) Insert four small sections of the Quad-Ring® cord into the lubrication groove, as shown at the red arrows on Figure 159. Continue to insert sections in direction of the blue arrows, followed by more sections, until the entire cord is mounted.
- 3) Use a knitting pin with a rounded tip or similar to carefully push the Quad-Ring® cord into the bottom of the lubrication groove – without damaging the sealing lips of the Turcon® ring. Make sure that the Quad-Ring® cord is evenly distributed. For mounting Roto Glyd Ring® V for shaft in closed grooves, apply the following installation procedure:
- 4) The O-Ring is installed in the groove.
- 5) The Turcon® Roto Glyd Ring® V seal ring, with Quad-Ring® installed, is compressed into a kidney-shape and placed in the groove, see Figure 157 and Figure 158.
- 6) Press the seal into the groove, into its original shape.
- 7) Ensure that the Quad-Ring® is in the correct position in the lubrication groove.
- 8) Calibrate the seal, see Figure 158.

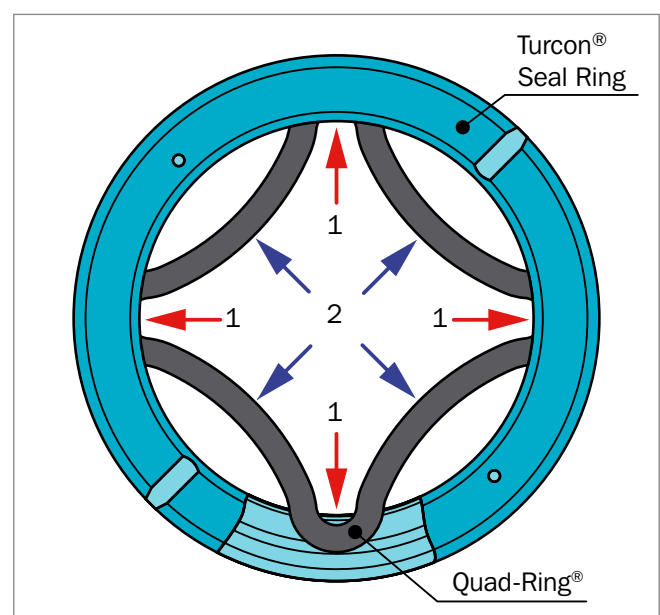

Figure 159: Insert sections of Quad-Ring® diagonally into the lubrication groove



INSTALLATION OF TURCON® ROTO VL SEAL® FOR SHAFT

Table 112: Closed Groove installation Limits

Turcon® Roto VL Seal® for Shafts		
Series No.	Material M12, M15, T40, Z54	Material Z53, Z80
	mm	mm
TE110	$\varnothing d_N \geq 30$	$\varnothing d_N \geq 30$
TE120	$\varnothing d_N \geq 30$	$\varnothing d_N \geq 40$
TE130	$\varnothing d_N \geq 50$	$\varnothing d_N \geq 50$
TE140	$\varnothing d_N \geq 80$	$\varnothing d_N \geq 80$
TE150	$\varnothing d_N \geq 125$	$\varnothing d_N \geq 125$
TE160	$\varnothing d_N \geq 200$	$\varnothing d_N \geq 400$

Before installing Roto VL Seal® for shaft in closed grooves the O-Ring is inserted and positioned at one side of the groove giving space for the concave seal back. The seal ring is folded and inserted in groove (see Figure 160). Then follow the same procedure as for Roto Glyd Ring®.

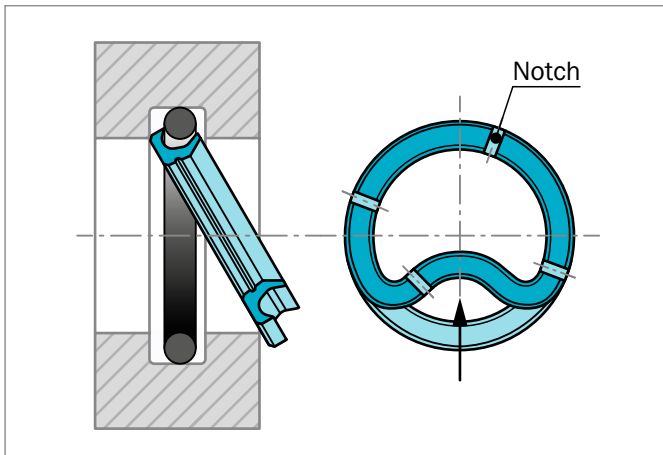

Figure 160: Installation of shaft Turcon® Roto VL Seal® in closed groove

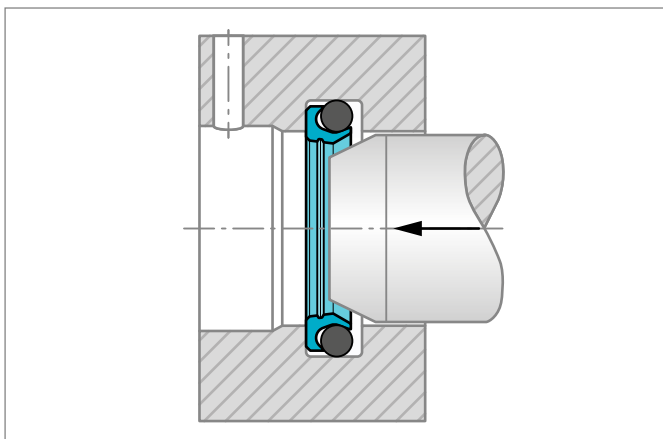

Figure 161: Direction of calibration of installed Roto VL Seal®

INSTALLATION RECOMMENDATION IN CLOSED GROOVES FOR BORE SEALS

Installation in closed grooves is possible for diameters according to Table 113 and Table 115.

Seal sizes for smaller diameters than stated in the Tables require split groove assembly.

CLOSED GROOVE INSTALLATION LIMITS FOR TURCON® ROTO GLYD RING® TYPE BORE SEALS:

Table 113: Closed Groove Installation Limits

Roto Glyd Ring®, Roto Glyd Ring® K, Roto Glyd Ring® S		
O-Ring Series	Material T40, M12, M15, Z54	Material T10, Z53, Z80
	mm	mm
000	$\varnothing D_N \geq 15$	$\varnothing D_N \geq 30$
100	$\varnothing D_N \geq 25$	$\varnothing D_N \geq 45$
200	$\varnothing D_N \geq 32$	$\varnothing D_N \geq 70$
300	$\varnothing D_N \geq 50$	$\varnothing D_N \geq 95$
400	$\varnothing D_N \geq 100$	$\varnothing D_N \geq 130$
8.4	$\varnothing D_N \geq 400$	$\varnothing D_N \geq 400$
12.0	$\varnothing D_N \geq 600$	$\varnothing D_N \geq 600$

Table 114: Closed Groove Installation Limits

Roto Glyd Ring® V			
Series No.	Bore Diameter D_N (mm)		
	Material M12, M15, T40	Material M04, M30, T10	Material T10, Z80, Z81, Z82
TG82	$D_N \geq 32$	$D_N \geq 45$	$D_N \geq 70$
TG83	$D_N \geq 50$	$D_N \geq 60$	$D_N \geq 95$
TG84	$D_N \geq 100$	$D_N \geq 100$	$D_N \geq 130$
TG85	$D_N \geq 400$	$D_N \geq 400$	$D_N \geq 400$



INSTALLATION WITH INSTALLATION TOOL FOR TURCON® ROTO GLYD RING® TYPE BORE SEALS:

Use of a three-piece installation tool is recommended for series production installation of Turcon® seals for Bore (see Figure 162).

The tool consists of:

- Installation Cone
- Expanding Pusher
- Sizing Sleeve

All parts should be made of a polymer material (e.g. POM, polyacetal) with a good surface finish to avoid damage to the seals.

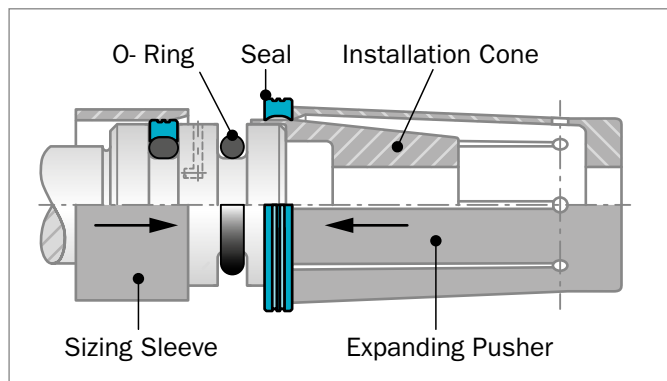

Figure 162: Expanding the Turcon® Roto Glyd Ring® etc. over the Installation Cone using an Expanding Pusher

- Pull the O-Ring over the piston into the groove (take care not to burst the O-Ring).
- Expand the Turcon® Seal Ring over the Installation Cone using the Expanding Pusher by a fast but smooth movement to assure an optimum snap-back of the seal element.
- Calibrate the seal with the Sizing Sleeve before it is installed in the bore.

INSTALLATION WITH INSTALLATION TOOL FOR TURCON® ROTO VL SEAL® FOR BORE:

Table 115: Closed Groove Installation Limits

Series No.	Turcon® Roto VL Seal® for Bore	
	Material M12, M15, T40, Z54	Material Z53, Z80
	mm	mm
TE210	$\varnothing D_N \geq 30$	$\varnothing D_N \geq 50$
TE220	$\varnothing D_N \geq 50$	$\varnothing D_N \geq 75$
TE230	$\varnothing D_N \geq 80$	$\varnothing D_N \geq 110$
TE240	$\varnothing D_N \geq 135$	$\varnothing D_N \geq 150$
TE250	$\varnothing D_N \geq 200$	$\varnothing D_N \geq 200$
TE260	$\varnothing D_N \geq 400$	$\varnothing D_N \geq 400$

Before installing Roto VL Seal® for Bore in closed groove the O-Ring is inserted and positioned at one side of the groove giving space for the concave seal back. Then the seal ring is pushed over an Installation Cone and into the groove - note the difference in design of the Installation Cone depending on direction of installation (see Figure 163).

After insertion in the groove the seal is preferably calibrated with a Sleeve before the piston is inserted in the cylinder Figure 162.

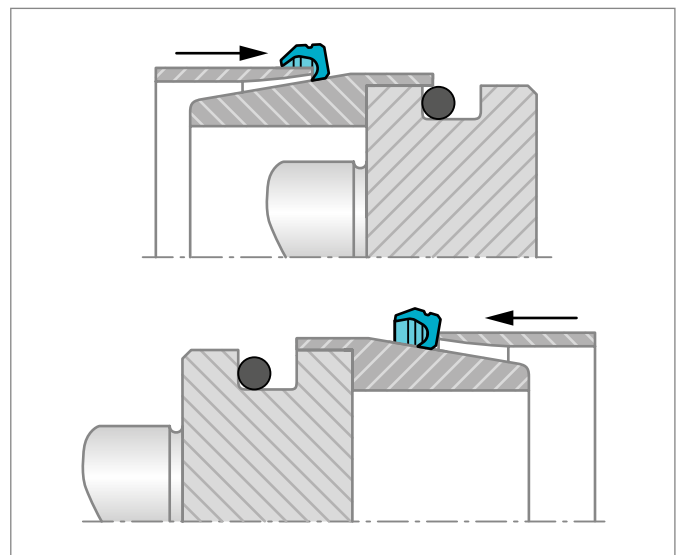

Figure 163: Installation of bore Turcon® Roto VL Seal® in closed groove using an expanding pusher over an installation cone

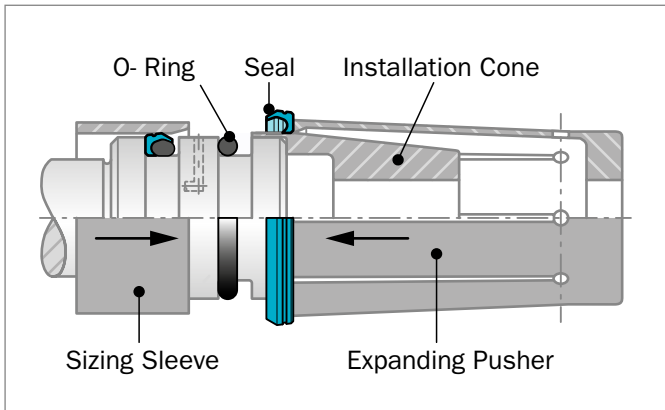

Figure 164: Calibration and installation of bore Turcon® Roto VL Seal® by an Installation Cone and Expanding Pusher

INSTALLATION WITHOUT TOOLS FOR BORE SEALS

If installation has to be performed without installation tools, however, the following points should be observed:

- Turcon® Seal Rings can be installed more easily by heating in oil, water or using a hot air fan to approximately +80 °C to +100 °C (expanding and then sizing).
- First, insert the O-Ring into the piston groove.
- Ensure the O-Ring is not twisted in the groove.
- Fit the Turcon® Seal Ring into the lower groove area.
- Expand the seal ring by using a woven cotton or plastic packing band and allow snapping into the piston groove.
- Centre the seal ring.
- Use no sharp edged tools .

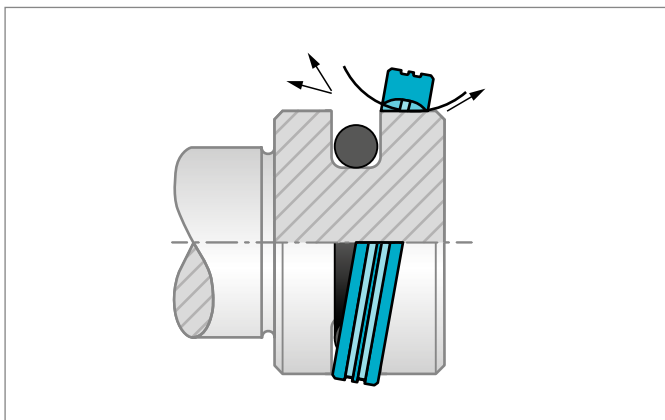

Figure 165: Schematic installation of the Turcon® seal ring

- Calibration of the seal ring can be carried out in the corresponding housing, provided it has the required lead-in chamfer as per Table 116. Otherwise use a calibration sleeve.

LEAD-IN CHAMFER

In order to avoid damage during installation, lead-in chamfers and rounded edges must be provided on the shaft or housing (see Figure 157 and Figure 158). If this is not possible for design reasons, a separate installation tool is recommended.

The minimum length of the lead-in chamfer depends on the profile size of the seal and can be seen from the following tables. If concentricity between the parts is not ensured during installation the lead-in chamfers must be increased correspondingly.

For the surface quality of the lead-in chamfer, the same recommendations apply as given for the sealing surfaces in Table 116.

Table 116: Minimum Lead-in Chamfers for Turcon® Roto Seals

O-Ring Series	Lead-in Chamfers Length C mm	
	15°	20°
000	2.5	2.0
100	3.0	2.5
200	3.5	3.0
300	5.0	4.0
400	6.5	5.0
8.4	7.5	5.5
12.0	10.5	8.0

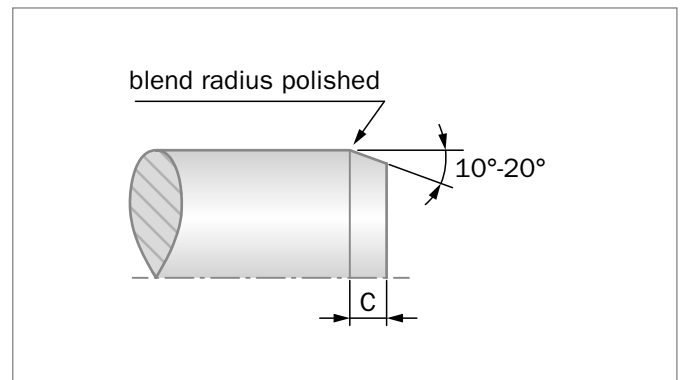

Figure 166: Lead-in chamfer on shaft

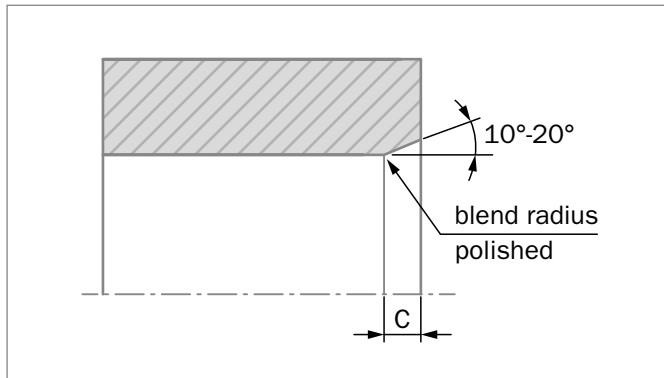

Figure 167: Lead-in chamfer on housing

SURFACE FINISH RECOMMENDATIONS

Shaft and bore surface finish for rotary motion must have no machining leads and be free from scratches, nicks or defects, as well as any contamination. For the rotating surface and the seal groove, plunge grinding is recommended for the finishing process.

Table 117: Surface Finish Recommendations

Parameter	Surface Roughness μm	
	Mating Surface	
	Turcon® and Zurcon® Materials	Groove Surface
R_{max}	0.63 – 2.50	< 16.0
R_z	0.40 – 1.60	< 10.0
R_a	0.05 – 0.20	< 1.6

MATING SURFACE MATERIALS

Surface hardness is recommended to be above 55 HRc, hardness depth minimum 0.3 mm. In certain circumstances such as low circumferential velocity, good lubrication and no contamination, surfaces with hardness levels below 55 HRc are suitable.

- Coated surfaces must be finished with particular care.
- Chrome-plating must not peel off in service.
- Good heat dissipation must be assured by the coating.



Turcon[®] Buffer Ring with Back-pressure Relief

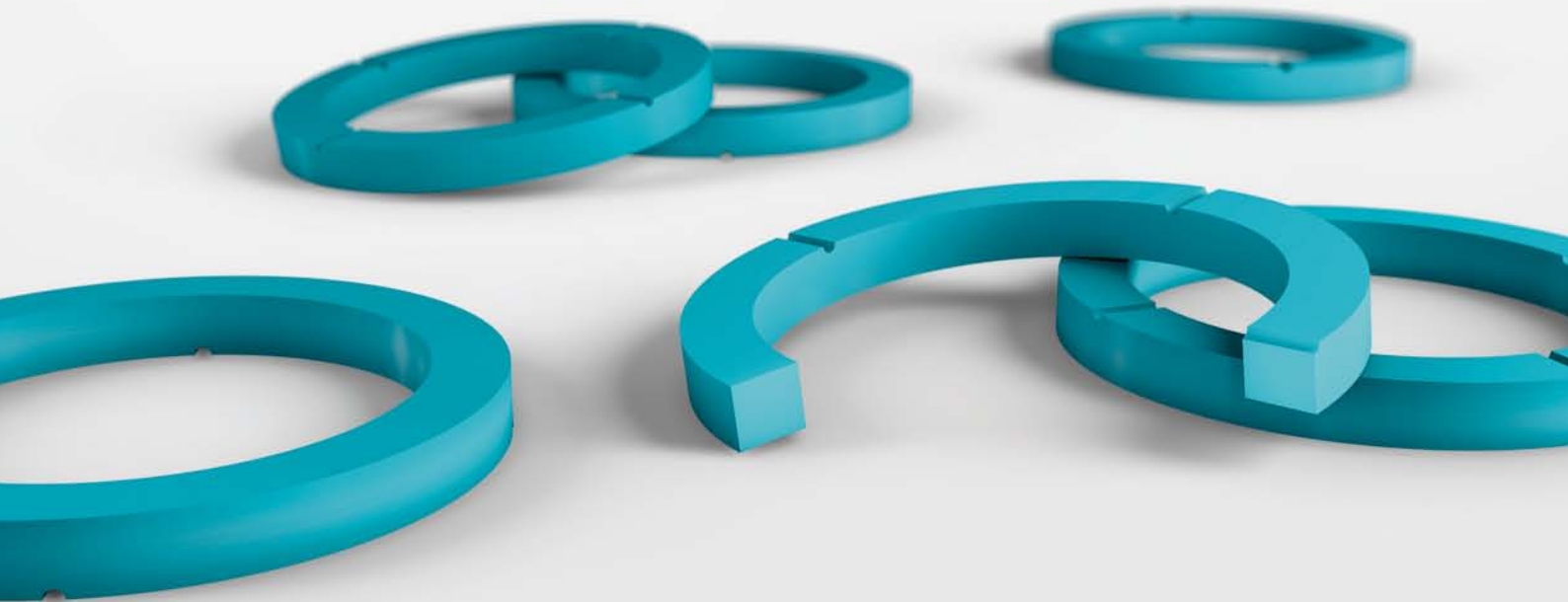





■ Turcon® Buffer Ring with Back-pressure Relief

■ Description

The term “Buffer Ring” has traditionally been used for elements protecting the actual sealing system from damaging high pressure peaks. The Turcon® Buffer Ring is not required to have high sealing effect but it must prevent pressure trap between the Buffer Ring and the actual seal.

Turcon® Buffer Ring is successfully used as seal in injection molding machines for the Rotating Injection Unit – a unique utilization of a basic element for helical movements securing long lifetime.

The Buffer Ring concept is also used in several other situations - alone, as a set of two or as high pressure protection for other rotary or linear seals by lowering their contribution to friction and seal wear.

METHOD OF OPERATION

Turcon® Buffer Ring is kept in contact with the counter surface by a small interference fit and only activated by differential pressure over the seal. It is further characterized by having notches on one side as relief for backpressure.

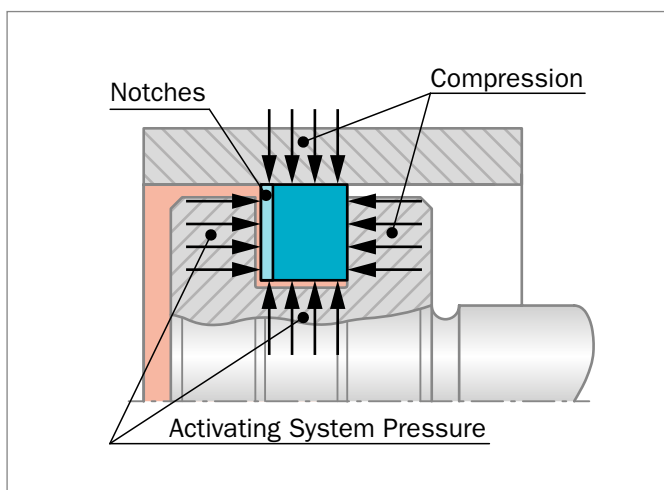

Figure 168: Pressure activation of Turcon® Buffer Ring

The sealing effect is higher and much safer than a Z-cut Piston Ring. Without an O-Ring as activation and static sealing elements the fluid film is excessive between the Buffer Ring and moving counter surfaces providing very low friction and wear resulting in long service life.

The pressure activation takes place in axial and radial outwards directions for bore sealing (radial and inwards for shaft sealing) offering sealing function in a number of applications.

With notches on one side the Buffer Ring is a single acting seal ring often used as protector of a common sealing system against peak pressures where the notch prevents risk of pressure trap.

If a double-acting sealing effect is required it is necessary to install two Buffer Ring back to back to take the pressure from both sides (see Figure 168 and Figure 169).

ADVANTAGES

- For rotary, helical and linear motion
- Minimum friction contribution for low energy loss
- Minimum heat generation
- Fully lubricated sealing surfaces
- Low wear ensures long service life
- Protects against pressure peaks
- Increased radial clearance possible
- Prevents pressure trap
- One-piece element
- For lubricating and non lubricating fluids depending on seal material (Turcon®, Zurcon®)

Not recommended for static function because of absence of elastomer activation and static sealing element.

SHAFT SEALING SYSTEM

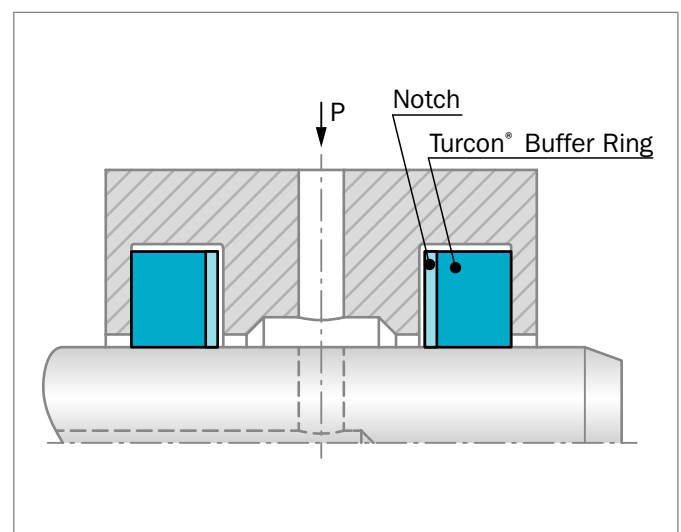

Figure 169: Right installation of Turcon® Buffer Ring

BORE SEALING SYSTEM

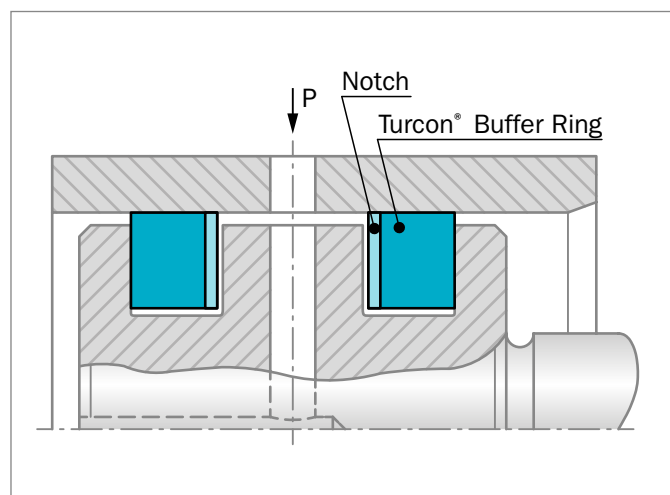

Figure 170: Right installation of Turcon® Buffer Ring

APPLICATIONS

Buffer Rings are typically used:

- Where the requirement of tightness is less than 100%
- Where a wet or fully lubricated seal is required
- Protection of peak pressures in front of sealing systems.
- For very low friction and /or long life sealing systems (with low requirement to tightness)
- Rotating Injection Units in Injection molding machines

OPERATING CONDITIONS

The Turcon® Buffer Ring is recommended for rotary and helical service and reciprocating movements with a length of stroke at least twice the groove width.

Pressure:	Up to 30 MPa as single seal element
Speed:	Up to 15 m/s - linear
pv:	Up to 10 MPa x m/s - rotary
Frequency:	Up to 1 Hz
Temperature:	Piston seals: +5 °C to +160 °C*) Rod seals: -45 °C to +70 °C**)
Media:	Mineral oil-based hydraulic fluids, flame retardant hydraulic fluids, environmentally friendly hydraulic fluids (bio-oils), phosphate ester, water and others, depending on the seal material compatibility.
Clearance:	The maximum permissible radial clearance S_{max} is shown in Table 121 and Table 122 as a function of the operating pressure and functional diameter.

IMPORTANT NOTE

The above data are maximum values and cannot be used at the same time, e.g. the maximum operating speed depends on material type, pressure, temperature and gap value.

Temperature range also depends on media.

*) For bore seals: Buffer Ring is not activated by an elastomer element to compensate for temperature expansion/contraction and if unpressurized service occurs at temperatures below +5 °C the seal ring will contract and might lose contact to the bore surface.

***) For shaft seals: Buffer Ring is not activated by an elastomer element to compensate for temperature expansion/contraction and if unpressurized service occurs at temperatures above +70 °C the seal ring will expand and might lose contact to the shaft surface.

In general: Before an application with Buffer Ring is qualified for service, functional tests must be performed on all expected working conditions.

INSTALLATION INSTRUCTIONS

Turcon® and Zurcon® materials recommended for Buffer Seal are flexible and installation is done as for Turcon® Roto Glyd Ring® see page 309.

Closed groove installation limits for Buffer Ring® see Table 109 and Table 110.

RECOMMENDED MATERIALS

The following material combinations have proven effective for hydraulic applications:

Turcon® Buffer Ring® in Turcon® M12

All round material for hydraulic applications with reciprocating, short stroke or helical movements in mineral oils, flame retardant hydraulic fluids HFC, phosphate ester or bio-oils:
Material code: M12

Turcon® Buffer Ring® in Turcon® M15

Material with high sealing effect for rotary or oscillating applications in fluids with good lubrication:
Material code: M15

Turcon® Buffer Ring® in Turcon® T40

For fluids with low lubricating properties:
Material code: T40

**Table 118: Turcon® and Zurcon® Materials for Buffer Ring**

Material, Applications, Properties	Code	Mating Surface Material	MPa as Single Seal Element
Turcon® M12 First material choice for seals in linear and helical motion Overall improved properties For new constructions and updating For all commonly applied hydraulic fluids including fluids with low lubrication performance Lowest friction and best sliding properties Lowest wear on seals Improved absorption of abrasive contaminants Low wear or abrasion of counter surface Mineral fiber and Additives filled Color: Dark gray	M12	Steel Steel hardened Steel chrome plated (rod) Steel plated (rod) Cast iron Stainless steel Titanium Aluminum (tubes)	30
Turcon® M15 For lubricating fluids Excellent for rotary service High sealing effect Very good wear properties Low friction Polyaramid, mineral fiber, lubricant and graphite filled Color: Dark gray	M15	Steel hardened Steel chrome plated (shaft) Steel plated (shaft) Cast iron	30
Turcon® T40 For linear, rotary and turning movements in fluids with low lubricating properties, e.g. water Surface texture not suitable for gasses Carbon fiber filled Color: Grayite filled Color: Black	T40	Steel Steel hardened Steel chrome plated (shaft) Cast iron Stainless steel Aluminum	30
Zurcon® Z53* For mineral oil based fluids Linear and slowly turning movements Very high abrasion and extrusion resistance For counter surface with rougher surface finish Hard to install Limited chemical resistance Max. working temperature +110 °C Cast polyurethane Color: Yellow to light-brown	Z53	Steel Steel hardened Steel chrome plated (rod) Cast iron Stainless steel Ceramic coating	30

Table is continued on next page

Material, Applications, Properties	Code	Mating Surface Material	MPa as Single Seal Element
<p>Zurcon® Z80*</p> <p>For lubricating fluids and fluids with low lubricating properties, water, air and gases at low pressure.</p> <p>Dry air pneumatics</p> <p>Linear and slowly turning movements</p> <p>Good abrasion and extrusion resistance</p> <p>For service in abrasive conditions and media with particles</p> <p>Good chemical resistance</p> <p>Not for constant rotation</p> <p>Max. working temperature +80 °C</p> <p>UHMWPE (Ultra high molecular weight polyethylene)</p> <p>Color: White to off-white</p>	Z80	<p>Steel</p> <p>Steel hardened</p> <p>Steel chrome plated (rod)</p> <p>Stainless steel</p> <p>Aluminum</p> <p>Ceramic coating</p>	30

* OD max. ø 2,300 mm – ID max. ø 2,200 mm.

Highlighted materials are recommended.



■ Installation Recommendation for Shaft

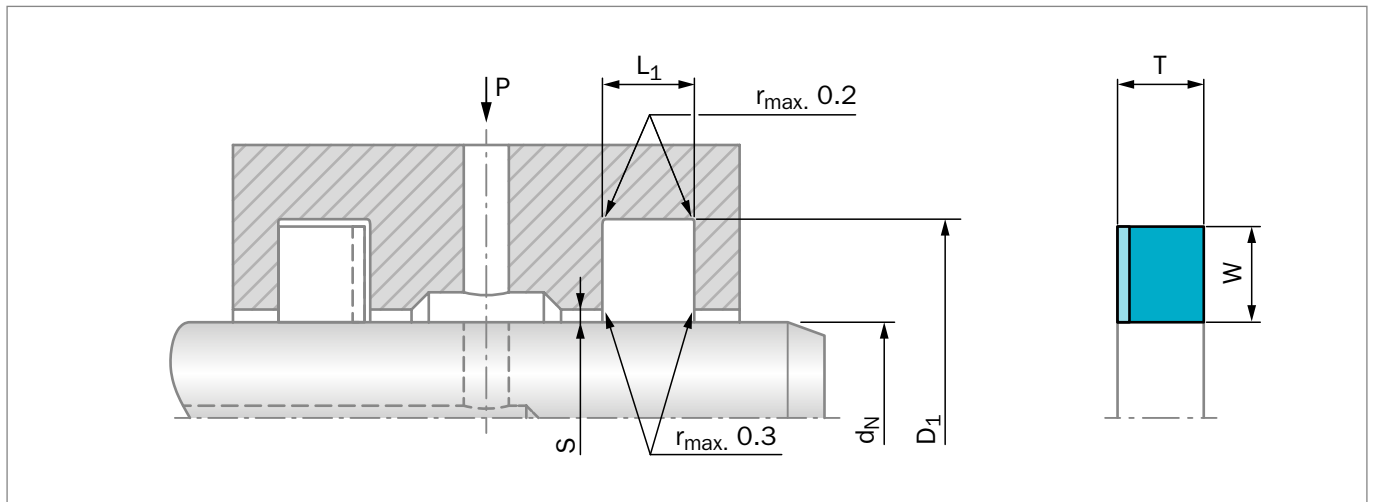

Figure 171: Installation Drawing

Table 119: Installation Dimensions – Standard Recommendations

Series Number	Shaft Diameter d_N f8/h9		Groove Depth $D_1 +0.4/-0$	Groove Width $L_1 +0.2/-0$	Ring Thickness W	Ring Width T	Radial Clearance S_{max}^*			Min. Dia. for Closed Groove Installation mm
	Recommended Range	Available Range					10 MPa	20 MPa	30 MPa	
RFB20	20.0 - 44.9	4.0 - 129.9	$d_N + 4.20$	2.00	1.95	1.85	0.20	0.15	-	20
RFB30	45.0 - 59.9	6.0 - 449.9	$d_N + 6.20$	3.00	2.95	2.85	0.25	0.20	0.15	35
RFB40	60.0 - 99.9	12.0 - 649.9	$d_N + 8.20$	4.00	3.85	3.85	0.30	0.25	0.20	50
RFB50	100.0 - 199.9	38.0 - 649.9	$d_N + 10.20$	5.00	4.85	4.85	0.35	0.30	0.25	80
RFB60	200.0 - 399.9	200.0 - 999.9	$d_N + 14.20$	6.00	6.80	5.85	0.40	0.35	0.30	120
RFB70	400.0 - 799.9	260.0 - 999.9	$d_N + 16.20$	7.00	7.80	6.80	0.45	0.40	0.35	330
RFB80	800.0 - 999.9	400.0 - 999.9	$d_N + 18.20$	8.00	8.80	7.80	0.50	0.45	0.40	650
RFB8X	1,000.0 - 2,600.0**	-	$d_N + 18.20$	8.00	8.80	7.80	0.50	0.45	0.40	1,000

* At pressures > 30 MPa: Use diameter tolerance H8/f8 (bore/shaft) in area of seal.

Slydring®/Wear-Rings are not applicable at very small clearances; consult the Slydring® catalog.

** Z53 max. \varnothing 2,200 mm

ORDERING EXAMPLE

Turcon® Buffer Ring, standard application:

Series: RFB50 (from Table 119)

Shaft diameter: $d_N = 120$ mm

TSS Part No.: RFB501200 (from Table 122)

Select the material from Table 118. The corresponding code numbers are appended to the TSS Part No. Together they form the TSS Article No. The TSS Article No. for all intermediate sizes not shown in Table 122 can be determined following the example opposite. Buffer Ring is available in all sizes. The ring will always be supplied with notches on one side only. Other ring thicknesses and ring widths are available upon request.

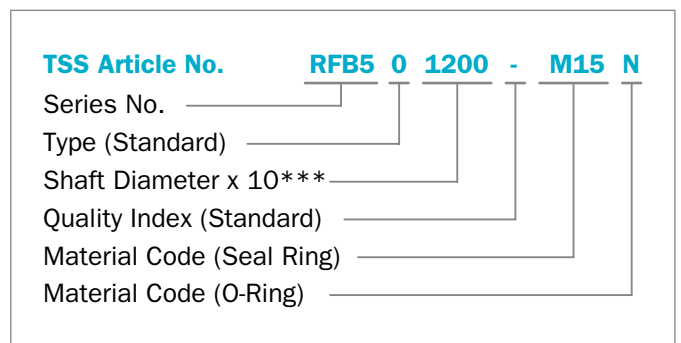

*** For diameters $d_N \geq 1,000.0$ mm multiply by 1
 Example: RFB8X for diameter $d_N = 1,500.0$ mm
 Article No. RFB8X1500-M15

Table 120: Standard Installation Dimensions / TSS Part Number

Shaft Dia.	Groove Dia.	Groove Width	TSS Part No.	Buffer Ring	Shaft Dia.	Groove Dia.	Groove Width	TSS Part No.	Buffer Ring
d_N f8/h9	D_1 +0.4/-0	L_1 +0.20		W x T	d_N f8/h9	D_1 +0.4/-0	L_1 +0.20		W x T
20.0	24.2	2.0	RFB200220	1.95 x 1.85	230.0	244.2	6.0	RFB60230	6.80 x 5.85
22.0	26.6	2.0	RFB200200	1.95 x 1.85	240.0	254.2	6.0	RFB602400	6.80 x 5.85
25.0	29.2	2.0	RFB200250	1.95 x 1.85	250.0	264.2	6.0	RFB602500	6.80 x 5.85
28.0	39.2	2.0	RFB200280	1.95 x 1.85	280.0	294.2	6.0	RFB602800	6.80 x 5.85
30.0	40.2	2.0	RFB200300	1.95 x 1.85	300.0	314.2	6.0	RFB603000	6.80 x 5.85
32.0	44.2	2.0	RFB200320	1.95 x 1.85	320.0	334.2	6.0	RFB603200	6.80 x 5.85
35.0	47.5	2.0	RFB200350	1.95 x 1.85	350.0	364.2	6.0	RFB603500	6.80 x 5.85
36.0	48.5	2.0	RFB200360	1.95 x 1.85	360.0	374.2	6.0	RFB603600	6.80 x 5.85
40.0	52.5	2.0	RFB200400	1.95 x 1.85	400.0	416.2	7.0	RFB704000	7.80 x 6.80
42.0	46.2	2.0	RFB200420	1.95 x 1.85	500.0	516.2	7.0	RFB705000	7.80 x 6.80
45.0	51.2	3.0	RFB300450	2.95 x 2.85	550.0	566.2	7.0	RFB705500	7.80 x 6.80
48.0	54.2	3.0	RFB300480	2.95 x 2.85	600.0	616.2	7.0	RFB706000	7.80 x 6.80
50.0	56.2	3.0	RFB300500	2.95 x 2.85	700.0	716.2	8.0	RFB707000	8.80 x 7.80
52.0	58.2	3.0	RFB300520	2.95 x 2.85	800.0	818.2	8.0	RFB808000	8.80 x 7.80
55.0	55.0	3.0	RFB300550	2.95 x 2.85	900.0	918.2	8.0	RFB809000	8.80 x 7.80
56.0	62.2	3.0	RFB300560	2.95 x 2.85	1,000.0	1,018.2	8.0	RFB8X1000	8.80 x 7.80
60.0	68.2	4.0	RFB400600	3.85 x 3.85	1,500.0	1,518.2	8.0	RFB8X1500	8.80 x 7.80
63.0	71.2	4.0	RFB400630	3.85 x 3.85	2,000.0	2,018.2	8.0	RFB8X2000	8.80 x 7.80
65.0	73.2	4.0	RFB400650	3.85 x 3.85	2,200.0	2,218.2	8.0	RFB8X2200	8.80 x 7.80
70.0	78.2	4.0	RFB400700	3.85 x 3.85	2,500.0	2,518.2	8.0	RFB8X2500	8.80 x 7.80
75.0	83.2	4.0	RFB400750	3.85 x 3.85	2,600.0	2,618.2	8.0	RFB8X2600	8.80 x 7.80
80.0	88.2	4.0	RFB400800	3.85 x 3.85					
85.0	93.2	4.0	RFB400850	3.85 x 3.85					
90.0	98.2	4.0	RFB400900	3.85 x 3.85					
95.0	103.2	4.0	RFB400950	3.85 x 3.85					
100.0	110.2	5.0	RFB501000	4.85 x 4.85					
105.0	115.2	5.0	RFB501050	4.85 x 4.85					
110.0	120.2	5.0	RFB501100	4.85 x 4.85					
115.0	125.2	5.0	RFB501150	4.85 x 4.85					
120.0	130.2	5.0	RFB501200	4.85 x 4.85					
125.0	135.2	5.0	RFB501250	4.85 x 4.85					
130.0	140.2	5.0	RFB501300	4.85 x 4.85					
135.0	145.2	5.0	RFB501350	4.85 x 4.85					
140.0	150.2	5.0	RFB501400	4.85 x 4.85					
150.0	160.2	5.0	RFB501500	4.85 x 4.85					
160.0	170.2	5.0	RFB501600	4.85 x 4.85					
170.0	180.2	5.0	RFB501700	4.85 x 4.85					
180.0	190.2	5.0	RFB501800	4.85 x 4.85					
190.0	200.2	5.0	RFB501900	4.85 x 4.85					
200.0	214.2	6.0	RFB602000	6.80 x 5.85					
210.0	224.2	6.0	RFB602100	6.80 x 5.85					
220.0	234.2	6.0	RFB602200	6.80 x 5.85					

Other dimensions and all intermediate sizes up to 2,600 mm diameter including imperial (inch) sizes can be supplied.



■ Installation Recommendation for Bore

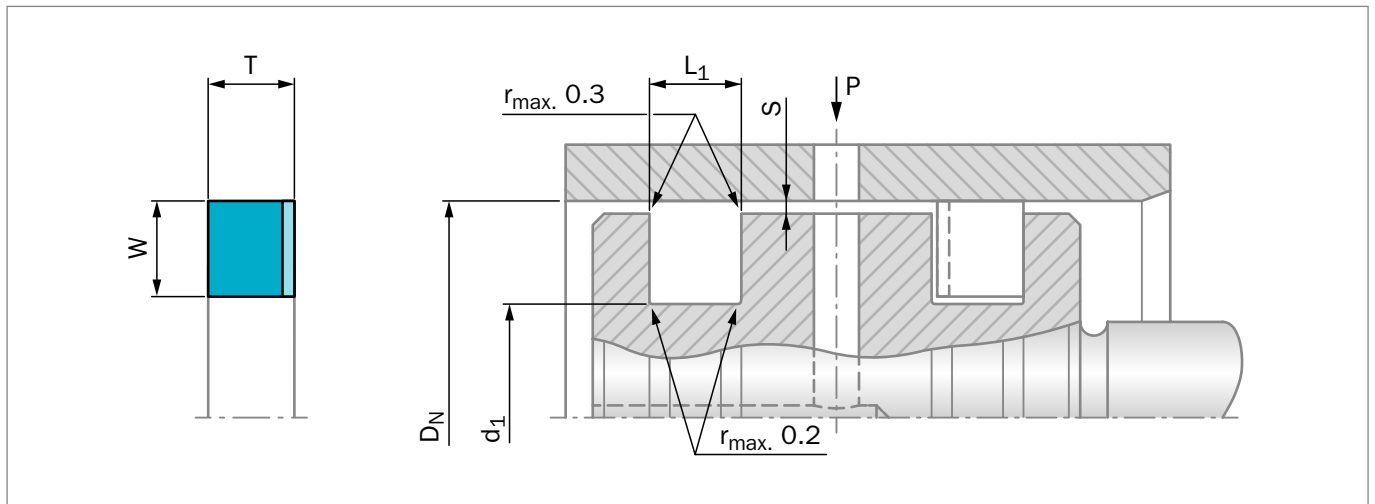

Figure 172: Installation Drawing

Table 121: Installation Dimensions – Standard Recommendations

Series Number	Bore Diameter D_N H9		Groove Depth d_1 0/-0.4	Groove Width L_1 +0.2/-0	Ring Thickness W	Ring Width T	Radial Clearance S_{max}^*			Min. Dia. for Closed Groove Installation mm
	Recommended Range	Available Range					10 MPa	20 MPa	30 MPa	
PFB20	20.0 - 44.9	8.0 - 199.9	$D_N - 4.20$	2.00	1.95	1.85	0.50	0.45	0.40	20
PFB30	45.0 - 59.9	16.0 - 379.9	$D_N - 6.20$	3.00	2.95	2.85	0.50	0.45	0.40	35
PFB40	60.0 - 99.9	40.0 - 479.9	$D_N - 8.20$	4.00	3.85	3.85	0.50	0.45	0.40	50
PFB50	100.0 - 199.9	80.0 - 699.9	$D_N - 10.20$	5.00	4.85	4.85	0.50	0.45	0.40	80
PFB60	200.0 - 399.9	130.0 - 999.9	$D_N - 14.20$	6.00	6.80	5.85	0.50	0.45	0.40	120
PFB70	400.0 - 799.9	320.0 - 999.9	$D_N - 16.20$	7.00	7.80	6.80	0.50	0.45	0.40	330
PFB80	800.0 - 999.9	750.0 - 999.9	$D_N - 18.20$	8.00	8.80	7.80	0.50	0.45	0.40	750
PFB8X	1,000.0 - 2,700.0**	-	$D_N - 18.20$	8.00	8.80	7.80	0.50	0.45	0.40	1,000

* At pressures > 30 MPa: Use diameter tolerance H8/f8 (bore/piston) in area of seal.
 Slydring® / Wear-Rings are not applicable at very small clearance; consult the Slydring® catalog.
 ** Z53 max. \varnothing 2,300 mm

ORDERING EXAMPLE

Turcon® Buffer Ring, standard application:

Series:	PFB50 (from Table 121)
Bore diameter:	$D_N = 120$ mm
TSS Part No.:	PFB501200 (from Table 120)

Select the material from Table 118. The corresponding code numbers are appended to the TSS Part No. Together they form the TSS Article No. The TSS Article No. for all intermediate sizes not shown in Table 122 can be determined following the example opposite. Buffer Ring is available in all sizes. The ring will always be supplied with notches on one side only. Other ring thicknesses and ring widths are available upon request.

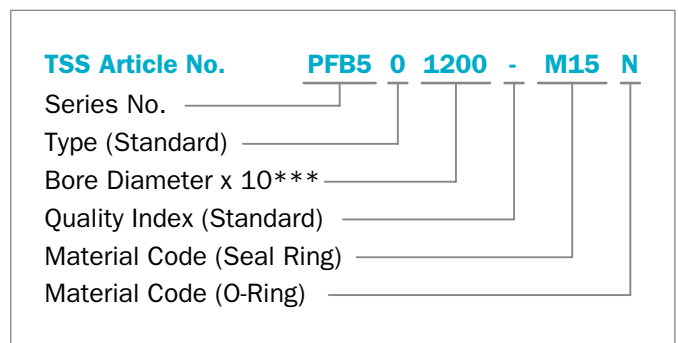

*** For diameters $D_N \geq 1,000.0$ mm multiply by 1
 Example: PFB8X for diameter $D_N = 1,500.0$ mm
 Article No. PFB8X1500-M15

Table 122: Standard Installation Dimensions / TSS Part Number

Bore Dia.	Groove Dia.	Groove Width	TSS Part No.	Buffer Ring	Bore Dia.	Groove Dia.	Groove Width	TSS Part No.	Buffer Ring
D_N f8/H9	d_1 +0/-0.4	L_1 +0.20		W x T	D_N f8/H9	d_1 +0/-0.4	L_1 +0.20		W x T
20.0	15.8	2.0	PFB200200	1.95 x 1.85	250.0	235.8	6.0	PFB602500	6.80 x 5.85
22.0	17.8	2.0	PFB200220	1.95 x 1.85	280.0	265.8	6.0	PFB602800	6.80 x 5.85
25.0	20.8	2.0	PFB200250	1.95 x 1.85	300.0	285.8	6.0	PFB603000	6.80 x 5.85
28.0	23.8	2.0	PFB200280	1.95 x 1.85	320.0	305.8	6.0	PFB603200	6.80 x 5.85
30.0	25.8	2.0	PFB200300	1.95 x 1.85	350.0	335.8	6.0	PFB603500	6.80 x 5.85
32.0	27.8	2.0	PFB200320	1.95 x 1.85	400.0	383.8	7.0	PFB704000	7.80 x 6.80
35.0	30.8	2.0	PFB200350	1.95 x 1.85	420.0	403.8	7.0	PFB704200	7.80 x 6.80
40.0	35.8	2.0	PFB200400	1.95 x 1.85	450.0	433.8	7.0	PFB704500	7.80 x 6.80
42.0	37.8	2.0	PFB200420	1.95 x 1.85	480.0	463.8	7.0	PFB704800	7.80 x 6.80
45.0	38.8	3.0	PFB300450	2.95 x 2.85	500.0	483.8	7.0	PFB705000	7.80 x 6.80
48.0	41.8	3.0	PFB300480	2.95 x 2.85	550.0	533.8	7.0	PFB705500	7.80 x 6.80
50.0	43.8	3.0	PFB300500	2.95 x 2.85	600.0	583.8	7.0	PFB706000	7.80 x 6.80
52.0	45.8	3.0	PFB300520	2.95 x 2.85	700.0	683.8	7.0	PFB707000	7.80 x 6.80
55.0	48.8	3.0	PFB300550	2.95 x 2.85	800.0	781.8	8.0	PFB808000	8.80 x 7.80
56.0	49.8	3.0	PFB300560	2.95 x 2.85	900.0	881.8	8.0	PFB809000	8.80 x 7.80
60.0	51.8	4.0	PFB400600	3.85 x 3.85	1,000.0	981.8	8.0	PFB8X1000	8.80 x 7.80
63.0	54.8	4.0	PFB400630	3.85 x 3.85	1,500.0	1,481.8	8.0	PFB8X1500	8.80 x 7.80
65.0	56.8	4.0	PFB400650	3.85 x 3.85	2,000.0	1,981.8	8.0	PFB8X2000	8.80 x 7.80
70.0	61.8	4.0	PFB400700	3.85 x 3.85	2,250.0	2,231.8	8.0	PFB8X2250	8.80 x 7.80
75.0	66.8	4.0	PFB400750	3.85 x 3.85	2,500.0	2,481.8	8.0	PFB8X2500	8.80 x 7.80
80.0	71.8	4.0	PFB400800	3.85 x 3.85	2,700.0	2,681.8	8.0	PFB8X2700	8.80 x 7.80
85.0	76.8	4.0	PFB400850	3.85 x 3.85					
90.0	81.8	4.0	PFB400900	3.85 x 3.85					
95.0	86.8	4.0	PFB400950	3.85 x 3.85					
100.0	89.8	5.0	PFB501000	4.85 x 4.85					
110.0	99.8	5.0	PFB501100	4.85 x 4.85					
115.0	104.8	5.0	PFB501150	4.85 x 4.85					
120.0	109.8	5.0	PFB501200	4.85 x 4.85					
125.0	114.8	5.0	PFB501250	4.85 x 4.85					
130.0	119.8	5.0	PFB501300	4.85 x 4.85					
135.0	124.8	5.0	PFB501350	4.85 x 4.85					
140.0	129.8	5.0	PFB501400	4.85 x 4.85					
150.0	139.8	5.0	PFB501500	4.85 x 4.85					
160.0	149.8	5.0	PFB501600	4.85 x 4.85					
170.0	159.8	5.0	PFB501700	4.85 x 4.85					
180.0	169.8	5.0	PFB501800	4.85 x 4.85					
190.0	179.8	5.0	PFB501900	4.85 x 4.85					
200.0	185.8	6.0	PFB602000	6.80 x 5.85					
210.0	195.8	6.0	PFB602100	6.80 x 5.85					
220.0	205.8	6.0	PFB602200	6.80 x 5.85					
230.0	215.8	6.0	PFB602300	6.80 x 5.85					
240.0	225.8	6.0	PFB602400	6.80 x 5.85					

Other dimensions and all intermediate sizes up to 2,700 mm diameter including imperial (inch) sizes can be supplied.

Mechanical Face Seals







■ Mechanical Face Seals

■ General Description

Mechanical Face Seals are a special form of mechanical seals. They are also known under other designations, such as lifetime seals, floating seals and heavy duty seals.

TYPES

There are two different types of Mechanical Face Seals. The most common form is Type DO, which is characterized by the use of an O-Ring as the secondary sealing element (see Figure 173).

Type DF, on the other hand, has an elastomer with a diamond-shaped cross-section-Ø as a secondary sealing element instead of the O-Ring (see Figure 174).

Both types consist of two identical metal seal rings which seal against each other on a lapped seal face.

Special designs, like that in Figure 175, are available on request. Seal types can also be divided by the use of different seal materials.

DESIGN FEATURES

The seals consist of two metallic seal rings. They are mounted in separate housing face to face. The elastomeric elements center the seal in the housing.

METHOD OF OPERATION

The elastomeric rings provide three different functions:

- They generate a uniform axial face load. Enough to avoid the open of the seals and not too high to avoid lapped surfaces damage.
- Transmit the torque from rotating half (seat) through the lapped surfaces to the static half.
- They guarantee flexibility to the whole system against vibration and misalignment.
- Prevent the sliding of half group assembled inside its seat.

It is important to know that only one half of the seal rotates; the interface between the two precision lapped mating surfaces rotating against the other at orthogonal angle to the shaft. They form a leak-proof seal. The seal has a wedge shaped gap from the ID to the seal face allowing for easy

access to lubricate the seal face. Lubrication is necessary at all times. The lubricant builds a thin film between the sliding faces by a capillary effect and centrifugal force.

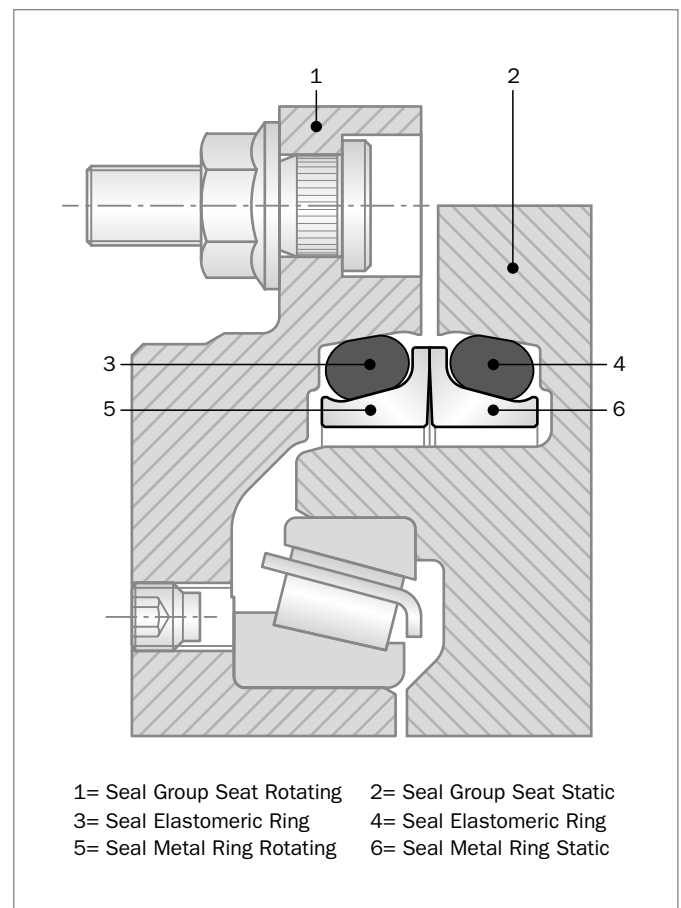

Figure 173: Mechanical Face Seals, Type DO

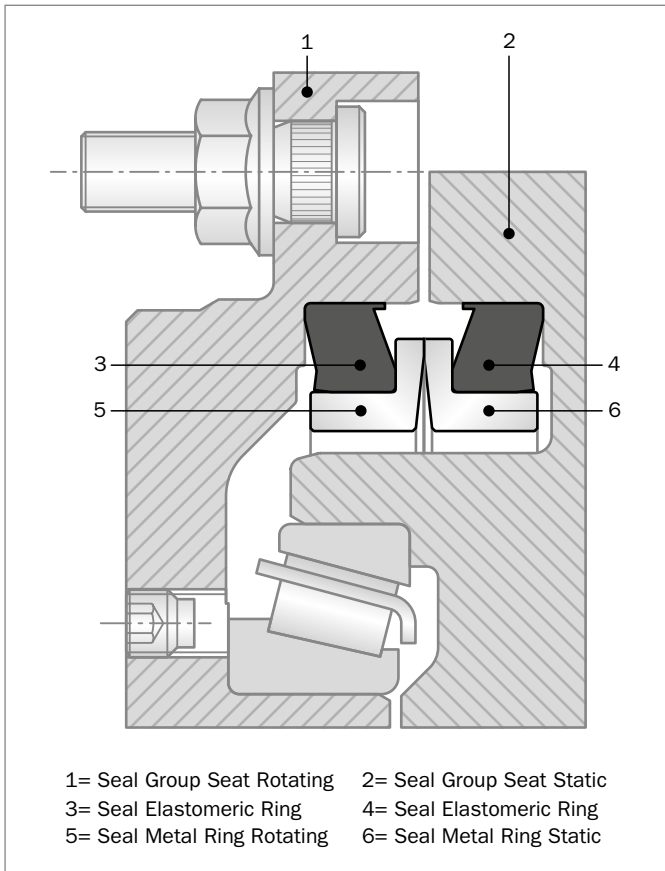

Figure 174: Mechanical Face Seals, Type DF

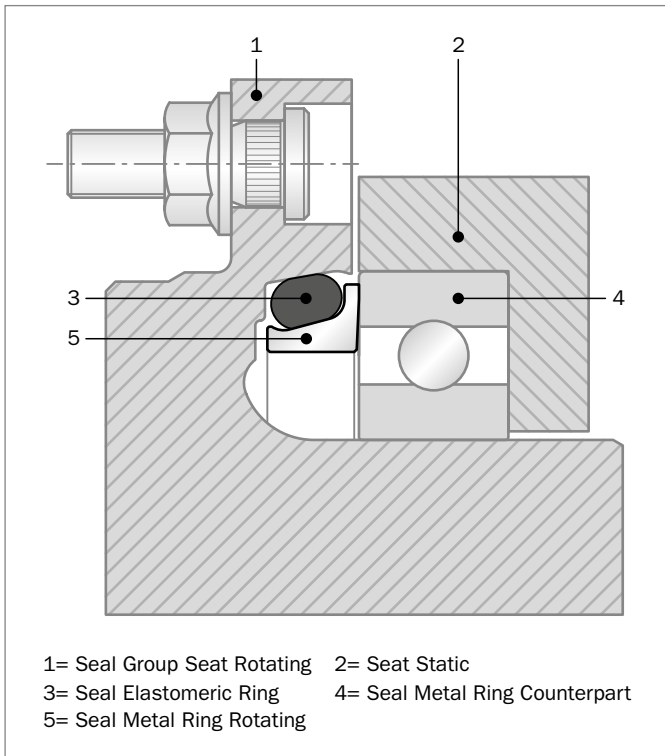

Figure 175: Special Design

ADVANTAGES

- Simple, reliable design
- High sealing effect against dirt, dust, water and abrasive media from the outside and against oil and grease from the inside
- Cost-effective
- Long service life
- Floating, useful against vibration or misalignment
- Maintenance-free
- Easy to assemble

Applications

Mechanical Face Seals are predominantly used to protect rotating elements/devices from external/internal heavy environment, with a mixture of wear (abrasion), chemical compatibility (corrosion), pressure (from outside to inside or vice versa).

These include:

Market segments as:

- Agriculture
- Mining
- Construction
- Industrial
- Military Equipment

Applications such as:

- Gearboxes
- Axles
- Undercarriages
- Tunnel Boring Machines
- Conveyor Systems
- Mixers
- Stirrers
- Conveyor systems

and other applications with similar conditions or where maintenance-free lifetime sealing is expected.



OPERATING CONDITIONS

The seals should not be subjected simultaneously to maximum pressure and maximum speed.

Operating Pressure:

The shaft seal is pressure-free under normal operating conditions.

The MFS are suitable to hold up to 0.15 MPa of differential pressure from outside to inside and from inside to outside. For higher differential pressures, please contact your local Trelleborg Sealing Solutions marketing company, which will analyze MFS suitability with the application.

SPEED

Cast Iron: 3 m/sec with oil lubrication
100Cr6: 1 m/sec with oil lubrication

For higher peripheral speeds, please contact your local Trelleborg Sealing Solutions marketing company, which will analyze MFS suitability with application peripheral speed.

RUN IN

It's strongly suggested during the first 10 hours of rotation to work with peripheral speeds not exceeding 1 m/sec.

TEMPERATURE

-50 °C to +180 °C (-58 °F to +356 °F), depending on the elastomeric ring material.

LUBRICATION, MEDIA

The lubrication serves two important functions, therefore it is needed in all cases. It reduces the friction between the seal face and the mating faces, and acts as a cooling agent for the complete shaft and housing.

The best results with regard to wear and service life are achieved with oil lubrication. Grease lubrication is possible but needs special attention, mainly relating to peripheral speed. It's necessary to have a minimum oil level of 1/3 of the seal inside diameter and a full level for grease. Please contact your local Trelleborg Sealing Solutions marketing company in other cases or if environmentally compatible bio-oils have to be used.

Materials

METAL PARTS

Metal parts of Mechanical Face Seals are available in three different alloy compounds. See following Table 123.

The hardness of the three different materials, on the sliding contact area, are the following ones:

- Bearing Steel (100Cr6) = 63 +/- 3 HRC
- Ni Hard alloy = 60 +/- 4 HRC
- Chromium based Alloy = 66 +/- 3 HRC

Contact your local Trelleborg Sealing Solutions marketing company to identify suitable material for related application.

Table 123: Alloy Composition

Material Chemical Composition %	Bearing Steel Material: 100Cr6	Ni Hard Alloy Material:	Chromium Base Alloy Material:
C	0.95 - 1.10	2.3 - 3.6	3.4 - 3.8
Cr	1.4 - 1.6	1.2 - 2.0	15.00 - 19.00
Ni	-	2.0 - 5.0	-
Fe	Balance	Balance	Balance

The analysis range serves to take account of the cross section. Deviations can be tolerated as far as the microstructure and the mechanical properties are not affected.

ELASTOMERIC RING

The elastomeric rings of MFS are available in different compounds, as in Table 124.

Table 124: Elastomeric Ring Compound

Type	Temperature Range (min / max) °C		Hardness Available SH A: +/-5			Mechanical Resistance	Oil Suitability
NBR	-25	+100	50	to	70	Good	Good
NBR LT	-50	+100	60	to	70	Good	Good
HNBR	-30	+150	60	to	65	Very Good	Good
HNBR LT	-40	+150			65	Very Good	Good
FKM	-15	+200			65	Good	Good
VMQY	-50	+175			65	Quite Good	No EP



Elastomeric rings of MFS seals are available in different compounds. General different compounds can cover the mentioned temperature and hardness ranges. Please contact your local Trelleborg Sealing Solutions marketing company for more information and to analyze the best elastomeric ring compound suitable for use with the final application.

CORROSION TEST

During operation, Mechanical Face Seals can be exposed not only to physical and thermal stresses, but also to extreme environmental stresses.

In collaboration with the Material Engineer Department of University of Modena (Italy) and Reggio Emilia (Italy), we have analyzed metal ring corrosion, simulating yearly consumption value using the Tafel Method. The Tafel test results are reported in Table 125.

Table 125: Tafel Analysis

Type	NaCl Solution	Sulphide Solution
	Corrosion mm/year	Corrosion mm/year
Bearing Steel	9.40	29.30
Ni hard alloy	1.80	5.40
Chromium based Alloy	1.83	5.05

■ Design Instructions

SEAL HOUSING

The installation dimensions of the seal housing are shown in Table 126.

The axial gap (S) in the housing is such that it meets the demands of the construction machinery industry.

For higher peripheral speeds please contact your local Trelleborg Sealing Solutions marketing company.

It's necessary to avoid any burrs or cutting edges in the seats.

For the surface of the seal installation chamber, we recommend a machining quality of:

$$3.0 \mu < R_a < 6.0 \mu\text{m}$$

$$22 < R_z < 45$$

SHAFT

The Mechanical Face Seal does not contact the shaft. For this reason, no particular demands have to be met on the hardness or surface finish.

To ensure correct operation, a minimum gap must be maintained between the shaft and the inside diameter. This gap serves to supply the seal with lubricant.

■ Storage Conditions

The parts have to be stored according to several conditions:

- The single carton box and the inner packaging has to be intact without any opening until assembly.
- The parts have to be stored in a dry environment.
- The parts have to be stored in an environment with temperature between 0 °C and +30 °C.
- The parts have to be stocked far from sources of heat.
- The parts have to avoid any contact with light sources.

If the above conditions are respected, the MFS are protected for approximately 1 year sfrom the shipping date.

■ Installation Instructions

Please contact your local Trelleborg Sealing Solutions marketing company to receive detailed assembly instructions. The description of assembly procedure both for DO type and DF type follows.

PREPARATION FOR INSTALLATION

Mechanical Face Seals must be handled carefully, avoiding damage to the lapped surfaces. The installation area must be kept free from dust and dirt.

The installation should be carried out in the following steps.

PREPARATION BEFORE INSTALLATION

- Remove the seal from its packing only immediately before installation.
- Do not stand the seal on the lapped surface.
- The housing must be free of notches or burrs on installation radii and free from any residues of previous working operations e.g. dirt, grease, metal chips, etc.



INSTALLATION INSTRUCTIONS FOR THE TYPE DO

- Make sure that the O-Ring is not twisted. A twisted O-Ring may cause a looped effect.
- Check if O-Ring is properly placed back on the seal. The O-Ring must be seated in the outer radius inside the retaining lip.
- Clean the half seal groups in a volatile solvent or industrial denaturated alcohol and wait for it to evaporate, being sure that no oil film remains on the parts.
- Assemble each half seal into the house using an installation tool Figure 176. Use a uniform load over the tool to push the half group in to the house until elastomeric ring reaches the related house border. The Installation Tool has to touch only the O-Ring and not the metal ring and importantly not the related lapped surface. If you have any doubts or require assistance, please contact your local Trelleborg Sealing Solutions marketing company.
- When the tool touches the house all around the circumference, the installation phase is complete.

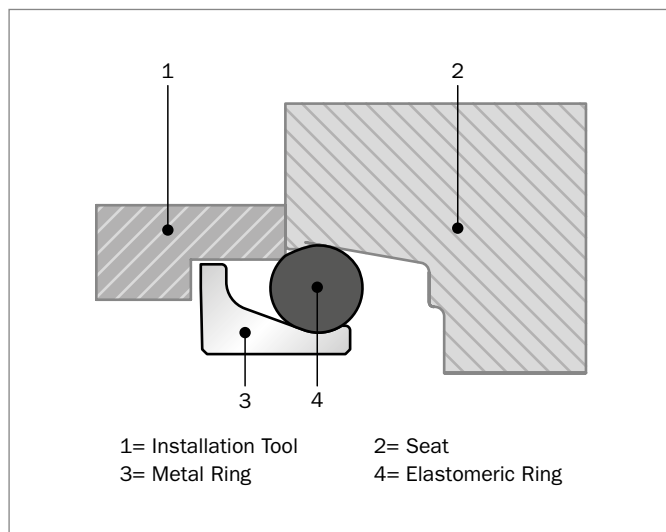
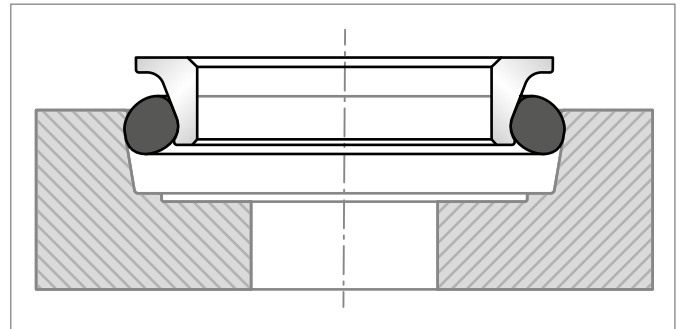

Figure 176: Installation Tool for DO Type

- Remove the tool and visually check the position of the O-Ring and seal. Make sure that everything is seated symmetrically.

The following picture shows the correct installation of each half seal into the housing:



The following pictures show incorrect installations:

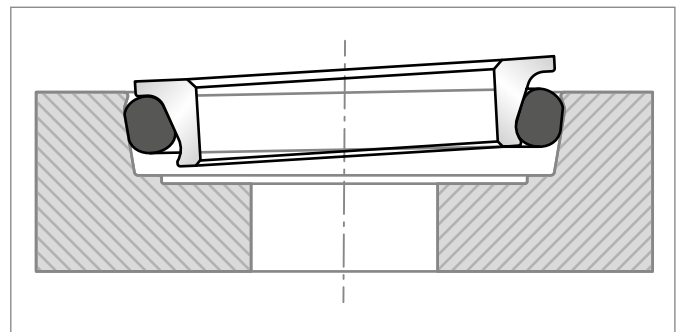

Figure 177: Metal ring slipped against the O-Ring

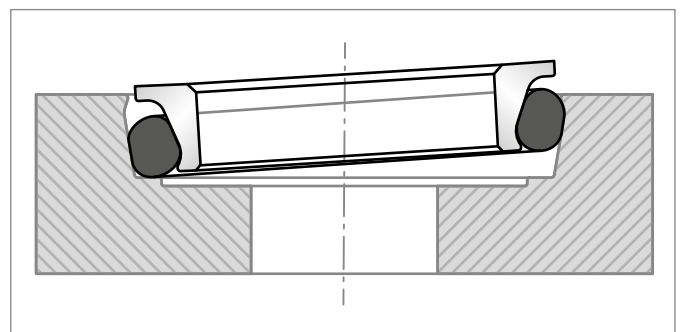

Figure 178: O-Ring slipped against the seat.

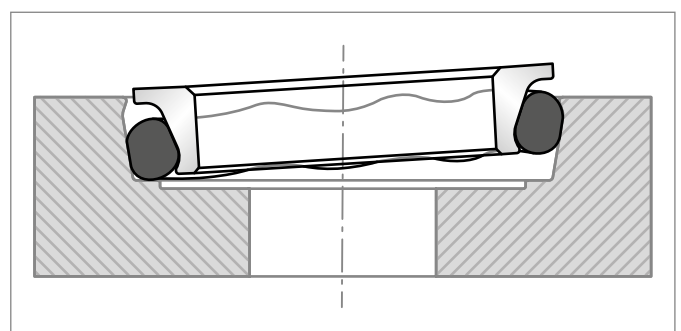
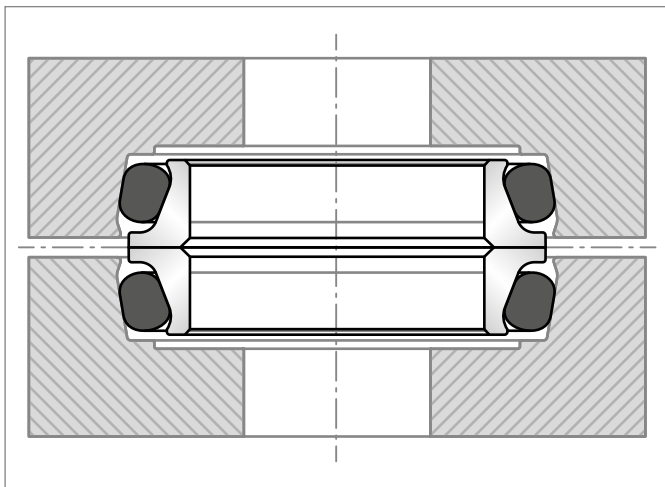

Figure 179: O-Ring slipped against the seat and waved against the metal ring.



- Clean both lapped surfaces with a small amount of denatured alcohol and wait for it to evaporate. Apply a thin film of clean oil to the faces.
- Tilt the two parts together, bringing the slide faces carefully into contact.
- Adjust the gap S via a slow assembly speed (for example, 2 mm/sec).

The following picture shows a correct assembly:



The following pictures show incorrect assemblies:

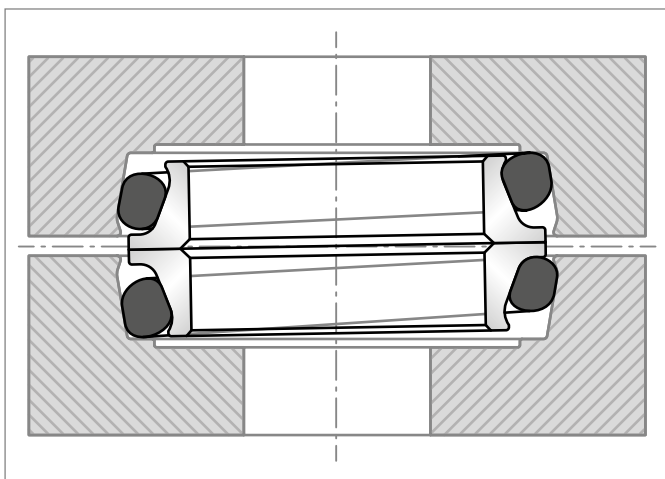

Figure 180: O-Rings slipped against seats and Mechanical Face Seal group is tilted.

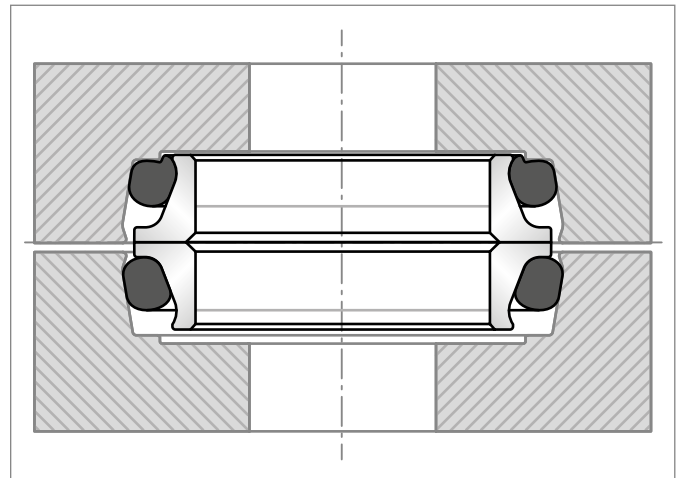

Figure 181: Upper half of the Mechanical Face Seal group has O-Ring slipped against the seat and on the seat bottom.

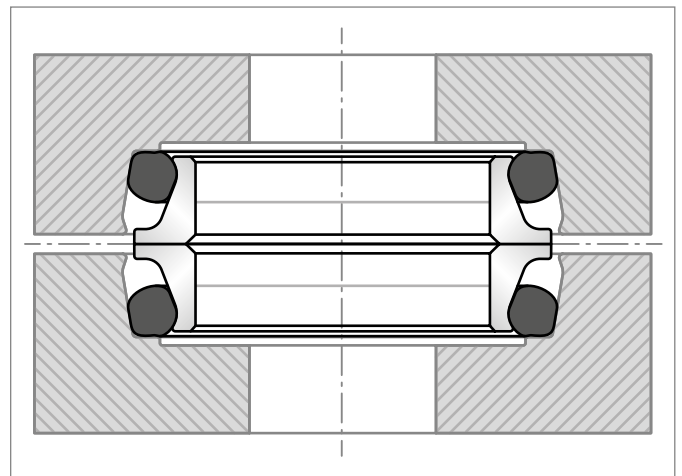

Figure 182: Both halves of the Mechanical Face Seal group have O-Rings slipped against the seat and on the seat bottom.

- Fill the housing with oil, and bleed if necessary.



In the event that the installation tool cannot be withdrawn or where the seal is of a special design, an installation O-Ring can be used. The installation O-Ring is placed between the O-Ring of the seal and rear of the ramp on the seal ring. As force is applied, using a tool (Figure 183) that touches the inner part of the metal ring close to the inner diameter and far from related lapped surfaces, to the seal ring during installation, the installation O-Ring backs up the O-Ring and will not allow it to roll up the ramp. After installation the O-Ring is easily removed (see Figure 183).

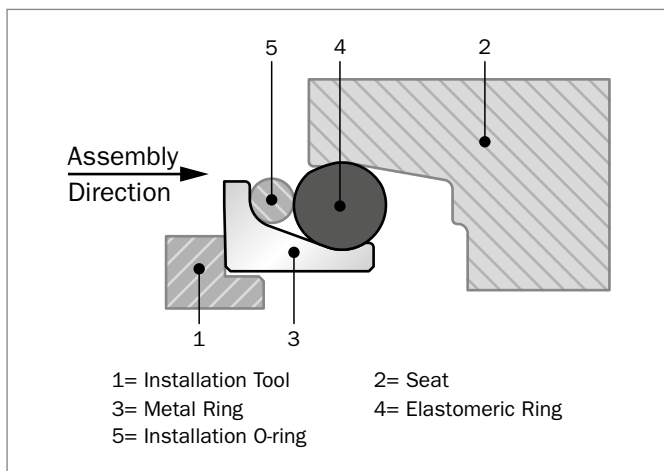

Figure 183: O-Ring as installation aid

INSTALLATION INSTRUCTIONS FOR THE TYPE DF

- Make sure that the Diamond-Shape Elastomeric Ring is well assembled on metal ring.
- Clean the half seal groups in volatile solvent or industrial denaturated alcohol and wait for it evaporation, being sure that no oil film stand on the parts.
- Assemble each half on the seal into the house using an installation tool Figure 184. Use an uniform load over the tool to push the half group in to the housing until elastomeric ring reaches the house bottom. The installation tool has to touch only inner part of metal ring close to Inner Diameter and far from related lapped surfaces.
- For any doubt or suggestion, please contact your local Trelleborg Sealing Solutions marketing company.
- Remove the tool and make a visual check for position of seal. Make sure that everything is seated symmetrically.
- Clean both lapped surfaces with few quantity of denaturated alcohol and wait for it evaporation. Then, apply a thin film of clean oil to the faces.
- Tilt the two parts together bringing the slide faces carefully into contact.
- Adjust the gap S via a slow assembly speed (2 mm/sec e.g.).

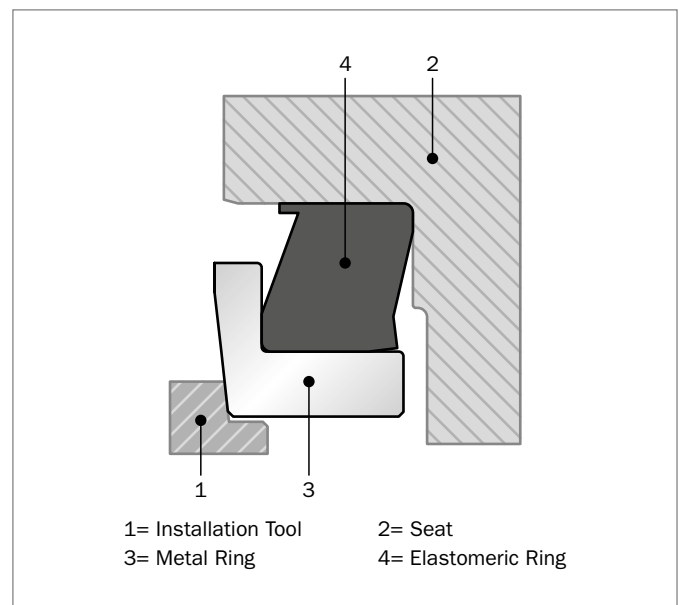

Figure 184: Installation Tool for DF Type



■ Installation Recommendations for Type DO in Bearing and Cast Iron Steel

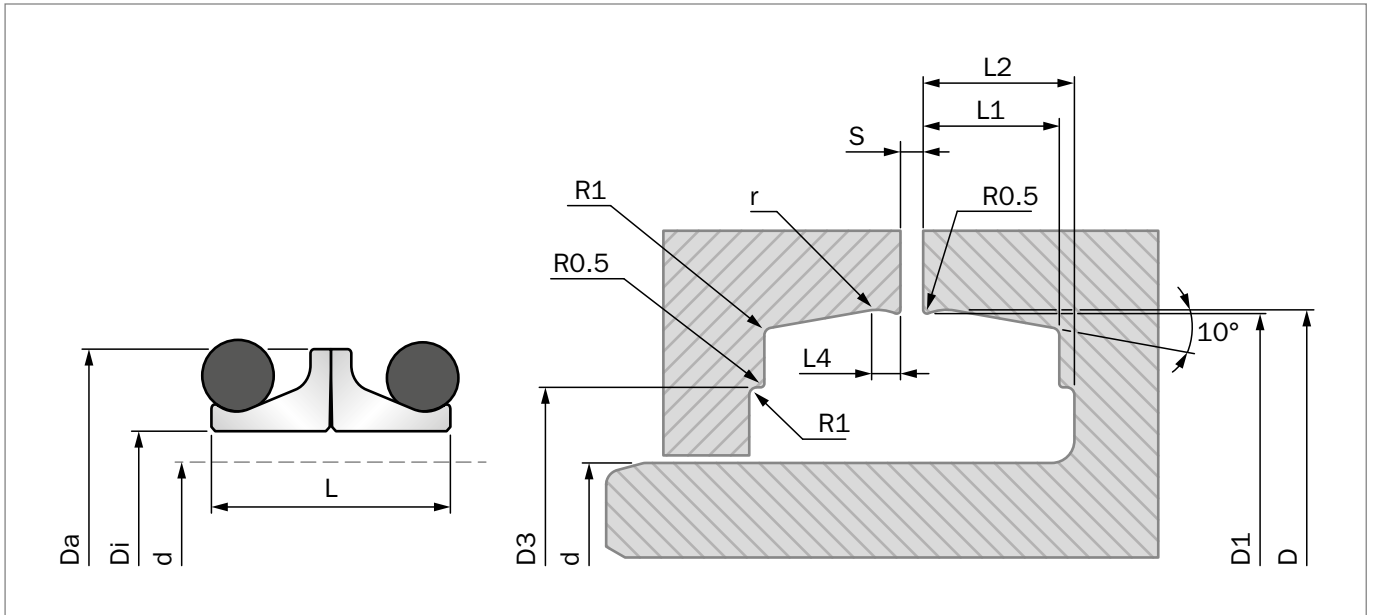

Figure 185: Installation Drawing

Table 126: Seal Group Dimensions, Type and Seat Dimensions

TSS Part No.	D _i	D _a	L	d _{max.}	D	D ₁	D ₃	L ₁	L _{2min.}	L ₄	r	S	BS	CI
TLDOA0340	34.00	45.00	14.00	30.00	47.00	46.50	42.00	6.50	8.00	1.00	1.00	1.50	●	
TLDOC0380	38.00	51.00	20.40	35.00	53.70	53.00	46.00	9.00	11.00	1.80	2.00	3.00	●	
TLDOA0380	38.00	51.00	20.00	35.00	53.70	53.00	46.00	9.00	11.00	1.60	2.00	3.00		●
TLDOA0390	39.00	50.00	14.00	35.00	52.00	51.50	46.00	6.50	8.00	1.00	1.00	1.50	●	
TLDOA0400 1)	40.00	52.00	20.00	36.00	55.00	54.20	46.00	9.00	11.00	1.00	1.00	3.00	●	
TLDOA0430	43.00	58.00	24.00	39.00	61.60	60.80	53.40	10.00	12.00	1.80	2.50	3.00	●	
TLDOA0430	43.00	58.00	24.00	40.00	62.00	61.30	51.00	10.50	12.50	2.00	2.00	3.00		●
TLDOB0450	45.00	58.00	21.60	41.00	61.60	61.00	54.00	10.50	12.50	1.80	2.50	3.00	●	
TLDOA0450	45.00	58.00	21.00	42.00	61.60	60.80	53.40	10.00	12.00	1.80	2.50	3.00		●
TLDOA0460 2)	46.00	59.00	20.00	42.00	61.60	61.20	53.00	9.00	11.00	2.00	2.50	3.00	●	
TLDOB0480	48.00	58.00	14.40	44.00	59.90	59.40	55.00	6.30	8.00	1.50	1.70	1.50	●	
TLDOC0480	48.00	62.00	26.00	45.00	68.00	67.20	58.00	12.00	14.00	2.00	3.00	3.00	●	
TLDOA0480	48.00	62.00	25.00	45.00	68.00	67.20	58.00	12.00	14.00	2.00	3.00	3.00		●
TLDOA0555	55.50	70.00	22.00	52.00	73.80	73.10	65.50	10.00	11.50	2.40	5.00	3.00	●	
TLDOA0555	55.50	70.00	22.00	52.50	73.80	73.10	55.50	10.00	11.50	2.40	5.00	3.00		●
TLDOB0560	56.00	70.00	26.00	53.00	76.00	75.20	66.00	12.00	14.00	2.00	2.50	3.00	●	
TLDOA0560	56.00	70.00	25.00	53.00	76.00	75.20	66.00	12.00	14.00	2.00	3.00	3.00		●
TLDOA0570	57.00	77.50	35.60	54.00	81.40	80.70	68.50	15.20	20.90	3.50	4.80	3.00	●	
TLDOC0580	58.00	74.00	27.00	55.00	79.40	78.60	67.00	13.50	15.50	2.00	3.00	3.00		●
TLDOB0580 3)	58.00	75.00	27.00	53.00	79.20	78.60	66.00	12.00	14.00	2.00	2.50	3.00	●	
TLDOA0600 2)	60.00	74.00	20.60	57.00	78.40	77.40	70.00	9.00	11.00	1.90	2.50	3.00	●	
TLDOA0600 2)	60.00	74.00	20.60	57.00	78.40	77.40	70.00	9.00	11.00	1.90	2.50	3.00		●

Seat Ramp Angle is 10°, except for a few exceptions shown in the notes at the bottom of the page.

1) 15° 2) 12° 3) 12°30' 4) 9°30'

All sizes in Bearing Steel (BS) could also be requested in Cast Iron (CI)



TSS Part No.	D _i	D _a	L	d _{max.}	D	D ₁	D ₃	L ₁	L _{2min.}	L ₄	r	S	BS	CI
TLDOB0610	61.00	73.00	17.60	58.00	75.80	75.50	66.80	6.50	7.50	1.00	1.40	3.00	●	
TLDOA0610	61.00	73.00	17.60	58.00	75.80	75.50	68.50	8.00	9.50	1.40	1.50	2.00		●
TLDOB0635	63.50	82.50	31.80	60.50	86.50	85.70	73.50	15.20	16.80	3.50	4.80	3.20	●	
TLDOA0635	63.50	82.50	31.80	60.50	86.80	85.90	74.00	15.00	17.00	3.00	2.50	3.00		●
TLDOA0640 2)	64.00	78.00	25.00	61.00	84.60	83.80	74.00	12.50	14.50	2.00	3.00	3.00	●	
TLDOA0640	64.00	78.00	25.00	61.00	84.60	83.60	74.00	12.50	14.50	2.00	3.00	3.00		●
TLDOA0660	66.00	85.00	28.00	63.00	90.00	89.20	78.00	14.00	16.00	2.00	3.00	3.00		●
TLDOA0675	67.50	86.50	31.80	64.00	91.00	90.00	78.00	14.50	17.00	2.80	5.00	3.00	●	
TLDOB0690	69.00	89.00	24.00	66.00	92.50	91.50	83.00	11.00	13.50	2.80	5.00	3.00	●	
TLDOA0690 2)	69.00	84.00	24.00	66.00	89.60	88.60	78.50	11.00	13.00	1.90	3.00	3.00	●	
TLDOA0690 2)	69.00	84.00	24.00	66.00	89.60	88.60	78.50	11.00	13.00	1.90	3.00	3.00		●
TLDOA0700	70.00	84.00	20.00	66.00	87.00	86.20	80.00	9.10	11.00	2.00	1.00	3.00	●	
TLDOB0700 2)	70.00	90.00	29.00	65.00	95.50	94.70	84.00	13.50	15.50	2.00	3.00	3.00	●	
TLDOB0710	71.00	84.00	20.00	68.00	87.40	86.70	80.80	8.50	10.00	1.80	2.00	3.00	●	
TLDOA0710 2)	71.00	90.00	29.00	68.00	95.50	94.70	84.00	13.50	15.50	2.00	3.00	3.00		●
TLDOA0725	72.50	92.00	35.60	70.10	96.00	95.20	83.00	15.20	20.90	3.50	4.80	3.00	●	
TLDOA0731	73.10	92.00	31.80	70.10	96.00	95.20	83.00	15.20	16.80	3.50	4.80	3.20	●	
TLDOB0730	73.00	92.00	31.80	70.00	96.20	95.40	84.00	15.00	17.00	3.00	4.00	3.00	●	
TLDOA0730	73.00	92.00	31.80	70.00	96.20	95.40	84.00	15.00	17.00	3.00	2.50	3.00		●
TLDOA0735	73.50	88.50	20.40	70.00	90.20	89.40	82.00	12.70	14.30	2.20	2.80	3.20	●	
TLDOB0740	74.00	86.50	22.50	70.00	91.40	90.70	80.00	9.50	11.50	2.00	3.00	3.00	●	
TLDOA0740	74.00	86.60	22.00	71.00	91.40	90.70	80.00	9.50	11.50	2.00	3.00	3.00		●
TLDOA0750	75.00	94.00	29.00	73.00	101.40	100.60	89.00	14.50	16.50	2.00	3.00	3.00	●	
TLDOA0775 1)	77.50	87.60	13.60	75.90	90.70	90.20	85.20	7.50	8.00	1.40	1.50	3.00	●	
TLDOA0795	79.50	92.50	20.00	76.00	96.00	95.30	88.00	8.50	10.50	1.80	2.00	3.00	●	
TLDOB0800	80.00	100.00	30.00	76.00	104.10	103.30	93.00	15.00	18.00	2.30	2.50	3.00	●	
TLDOA0800	80.50	99.50	29.00	77.00	105.00	104.20	92.00	14.50	16.50	2.00	3.00	3.00		●
TLDOA0810	81.00	98.00	28.00	78.00	102.30	101.30	91.00	12.50	14.50	2.80	5.00	3.00	●	
TLDOA0810	81.00	98.00	28.00	78.00	102.30	101.30	91.00	12.50	14.50	2.80	5.00	3.00		●
TLDOA0820	82.00	98.00	22.00	79.00	102.30	101.30	91.00	9.00	11.00	2.80	5.00	3.00		●
TLDOA0825	82.50	102.00	35.60	80.50	107.30	106.50	94.30	15.20	20.90	3.50	4.80	3.20	●	
TLDOA0860	86.00	99.00	20.00	81.00	102.00	101.20	94.00	9.00	11.50	2.00	3.00	3.00	●	
TLDOC0900 2)	90.00	109.00	32.00	86.00	112.50	111.70	104.00	14.50	17.00	3.20	3.00	3.00	●	
TLDOA0904	90.40	109.50	31.80	87.40	113.40	112.70	100.40	15.20	16.80	3.50	4.80	3.20	●	
TLDOC0900	90.50	109.00	32.00	87.00	112.50	111.70	104.00	14.50	17.00	3.20	3.00	3.00		●
TLDOB0900	90.00	104.60	26.00	87.40	107.30	106.70	100.40	11.80	14.20	2.90	2.80	3.20	●	
TLDOB0904	90.40	109.50	35.60	88.50	113.40	112.70	100.40	15.20	20.90	3.50	4.80	3.20	●	
TLDOA0920	92.00	109.00	22.00	89.00	113.80	113.40	105.00	9.50	11.50	1.80	2.50	3.00		●
TLDOB0920	92.00	109.50	22.00	88.00	113.80	113.00	105.00	9.50	11.50	2.00	3.00	3.00	●	
TLDOB0940	94.00	106.50	23.00	90.00	111.60	110.80	102.00	9.50	11.50	2.00	3.00	3.00	●	
TLDOA0940	94.00	106.50	22.00	91.00	111.60	110.80	102.00	9.50	11.50	2.00	2.50	3.00		●
TLDOC0950 2)	95.00	114.00	32.00	91.00	120.00	119.20	107.00	15.00	17.00	2.50	3.00	3.00	●	
TLDOA0950	95.00	111.00	24.00	92.00	115.60	114.80	108.00	11.00	12.50	1.80	2.00	3.00	●	

Seat Ramp Angle is 10°, except for a few exceptions shown in the notes at the bottom of the page.

1) 15° 2) 12° 3) 12°30' 4) 9°30'

All sizes in Bearing Steel (BS) could also be requested in Cast Iron (CI)



TSS Part No.	D _i	D _a	L	d _{max.}	D	D ₁	D ₃	L ₁	L _{2min.}	L ₄	r	S	BS	CI
TLDOB0950	95.00	114.00	31.00	92.00	120.00	119.20	107.00	15.00	17.00	2.50	3.00	3.00		●
TLDOA0965 1)	96.50	106.80	13.60	94.90	109.70	109.20	105.00	7.50	8.00	1.40	1.50	3.00	●	
TLDOA1000	100.00	119.00	31.60	97.00	123.00	122.20	110.00	15.20	16.80	3.50	4.80	3.20	●	
TLDOA1000	100.00	119.00	31.80	97.00	123.20	122.40	111.00	14.50	16.50	2.50	2.50	3.00		●
TLDOB1000	100.00	120.00	29.40	97.00	125.00	124.20	111.00	14.00	16.00	2.90	3.00	3.00		●
TLDOA1015	101.50	119.00	29.00	95.00	125.30	124.30	112.30	13.80	16.60	2.50	3.00	3.00	●	
TLDOA1020 2)	102.00	122.00	32.00	99.00	127.20	126.20	115.00	15.50	17.50	2.50	3.00	3.00		●
TLDOA1030 2)	103.00	122.00	32.00	99.00	127.20	126.20	115.00	15.50	17.50	2.50	3.00	3.00	●	
TLDOC1040	104.00	121.00	22.00	101.00	125.50	125.10	117.50	9.50	11.50	2.00	3.00	3.00		●
TLDOE1040	104.00	122.50	22.50	100.00	125.50	125.10	117.50	9.50	11.50	2.00	3.00	3.00	●	
TLDOD1040	104.00	117.00	22.00	100.00	121.00	120.20	107.00	9.50	11.50	2.00	3.00	3.00	●	
TLDOF1040	104.00	125.00	28.00	100.00	128.50	127.50	117.00	12.50	14.00	2.80	5.00	3.00	●	
TLDOA1070	107.00	125.00	24.00	103.00	130.40	129.40	119.50	11.00	13.50	2.80	5.00	3.00	●	
TLDOB1100 2)	109.00	127.00	32.00	106.00	133.00	132.00	121.00	15.00	17.00	2.50	3.00	3.00		●
TLDOA1090	112.00	132.00	32.00	104.00	136.50	135.50	124.00	15.50	17.50	2.50	3.00	3.00	●	
TLDOA1090	109.00	132.00	32.00	106.00	136.60	135.60	124.00	15.50	17.50	2.50	3.00	3.00		●
TLDOB1100	110.00	128.00	32.00	106.00	133.00	132.00	121.00	14.50	17.00	2.50	3.00	3.00	●	
TLDOB1110 2)	111.00	128.00	22.00	108.00	132.50	132.00	123.00	10.60	12.30	2.80	3.00	3.00	●	
TLDOA1145	114.50	129.00	23.50	107.50	134.10	133.10	126.00	10.40	11.90	2.80	5.00	3.00	●	
TLDOA1150	115.00	137.00	31.00	110.00	141.80	140.80	130.00	14.50	16.50	2.50	3.00	3.00	●	
TLDOA1150	115.00	137.00	31.00	112.00	141.80	140.80	130.00	14.50	16.50	2.50	3.00	3.00		●
TLDOB1170	117.00	140.00	28.00	113.00	142.50	141.50	132.00	12.50	14.00	2.80	5.00	3.00	●	
TLDOA1170	117.00	138.00	31.80	114.00	142.50	141.50	132.00	14.50	17.00	2.80	5.00	3.00	●	
TLDOA1190	119.00	140.00	28.00	115.00	142.50	141.50	132.00	12.50	14.00	2.80	5.00	3.00	●	
TLDOC1200	120.00	141.00	31.80	116.00	144.00	143.00	138.00	14.50	17.50	2.80	5.00	3.00	●	
TLDOD1200	120.00	142.00	38.00	116.00	149.00	148.00	133.00	17.00	19.00	2.50	3.00	4.00	●	
TLDOA1200	120.00	139.00	31.80	116.00	143.00	142.00	129.30	14.30	17.40	3.00	5.40	3.00	●	
TLDOA1240 4)	124.00	141.00	22.00	120.00	146.40	145.30	136.00	10.60	12.30	2.80	3.00	3.00	●	
TLDOA1240	124.00	141.00	22.00	121.00	145.80	145.00	136.00	9.50	11.50	2.00	3.00	3.00		●
TLDOB1250	125.00	144.10	31.80	120.00	148.50	147.50	136.00	14.30	17.40	3.00	5.00	3.00	●	
TLDOA1260	126.00	146.00	31.80	123.00	150.00	149.20	137.00	15.20	16.80	3.50	4.80	3.20	●	
TLDOA1265	126.50	139.00	26.80	123.50	143.80	143.10	136.90	11.80	14.20	2.90	2.80	3.20	●	
TLDOA1270	127.00	146.00	31.80	124.00	150.00	149.20	138.00	15.20	16.80	3.50	4.80	3.20	●	
TLDOA1270	127.00	146.00	31.80	123.00	150.20	149.40	138.00	14.00	16.00	2.50	2.50	4.00		●
TLDOD1270	127.00	141.20	25.40	124.00	143.80	143.10	136.90	11.80	14.20	2.90	2.80	3.20	●	
TLDOC1270	127.00	141.00	29.00	124.00	144.00	143.00	136.00	12.00	14.50	2.30	3.00	3.00	●	
TLDOD1300	130.00	152.00	38.50	125.00	159.00	158.00	144.00	18.50	20.50	2.50	3.00	3.00	●	
TLDOB1300	130.00	150.50	32.00	125.00	155.60	154.60	144.00	14.50	16.50	2.50	5.00	3.00	●	
TLDOD1300	130.00	152.00	38.00	127.00	159.00	158.00	144.00	18.50	20.50	2.50	3.00	3.00		●
TLDOA1427	142.70	156.90	25.40	139.70	159.70	158.90	152.10	11.80	14.20	2.90	2.80	3.20	●	
TLDOC1430	143.00	157.00	25.00	140.00	159.70	158.90	152.00	11.50	13.50	2.50	2.80	4.00		●
TLDOB1430	143.00	160.00	27.00	138.00	164.00	163.00	154.00	12.00	14.50	2.80	5.00	4.00	●	
TLDOA1440	144.00	157.50	26.00	139.00	160.00	159.00	154.50	12.00	14.50	2.80	5.00	3.00	●	

Seat Ramp Angle is 10°, except for a few exceptions shown in the notes at the bottom of the page.

1) 15° 2) 12° 3) 12°30' 4) 9°30'

All sizes in Bearing Steel (BS) could also be requested in Cast Iron (CI)



TSS Part No.	D _i	D _a	L	d _{max.}	D	D ₁	D ₃	L ₁	L _{2min.}	L ₄	r	S	BS	CI
TLDOC1460	146.00	175.00	38.00	142.00	180.50	179.50	162.00	17.70	20.50	3.00	6.30	6.30	●	
TLD0B1460	146.00	168.00	38.00	143.00	176.80	175.90	159.00	18.00	20.50	3.00	6.50	4.00	●	
TLDOA1460	146.00	168.00	38.00	143.00	177.00	176.00	159.00	18.00	20.00	2.50	3.00	4.00		●
TLDOA1463	146.30	171.70	38.00	142.30	176.80	175.90	158.90	18.40	20.30	3.70	6.30	6.30	●	
TLDOA1470	147.00	167.00	28.00	142.00	171.00	170.00	160.00	13.00	15.50	2.80	5.00	3.00	●	
TLDOA1480	148.00	170.00	31.00	142.00	175.60	174.60	164.00	15.00	17.00	2.50	3.00	4.00	●	
TLDOC1500	150.00	172.00	40.00	147.00	179.00	178.00	165.00	18.00	20.00	2.50	2.00	4.00	●	
TLDOC1500	150.00	172.00	40.00	147.00	179.00	178.00	165.00	18.00	20.00	2.50	3.00	4.00		●
TLDOA1530	153.00	171.50	28.00	149.00	176.30	175.30	164.50	12.50	14.50	2.80	5.00	3.00	●	
TLDOA1539	153.90	168.10	25.40	150.90	171.00	170.20	164.00	11.80	14.20	2.90	2.80	3.20	●	
TLD0B1530	154.00	168.00	25.00	151.00	171.00	170.20	164.00	11.50	13.50	2.50	2.80	4.00		●
TLDOA1540	154.00	168.10	27.00	151.00	171.00	170.00	162.50	12.00	14.50	2.30	3.00	3.00	●	
TLDOF1540	154.00	168.10	27.00	151.00	171.00	170.00	162.50	12.00	14.50	2.30	3.00	3.00	●	
TLDOC1540	154.00	173.50	31.80	151.00	178.00	177.00	166.00	14.50	17.00	2.80	5.00	3.00	●	
TLD0D1540	154.00	169.00	22.00	151.10	174.50	173.50	166.00	9.20	11.00	2.30	3.00	3.00	●	
TLDOE1540	154.00	170.00	21.00	151.00	175.10	174.10	167.00	9.20	10.00	2.30	3.00	3.00	●	
TLD0B1633	163.30	191.30	46.00	160.30	196.80	195.90	178.90	18.40	24.10	3.70	6.30	6.30	●	
TLD0B1630	163.00	191.00	38.00	160.00	196.40	195.50	179.00	18.00	20.00	3.10	6.40	4.00		●
TLDOA1633	163.30	191.20	38.00	160.30	196.80	195.90	178.90	18.40	20.30	3.70	6.30	6.30	●	
TLDOA1640	164.00	189.00	30.00	160.00	193.50	192.50	179.00	14.50	17.00	2.80	5.00	3.00	●	
TLDOA1650	165.00	181.00	27.00	161.00	185.00	184.00	176.50	12.00	14.50	2.70	4.00	3.00	●	
TLDOA1725	172.50	190.00	25.40	168.00	192.70	191.80	188.00	12.70	14.30	2.30	2.80	3.20	●	
TLDOA1740	174.00	190.00	25.40	170.00	192.70	191.80	188.00	12.70	14.30	2.30	2.80	3.20	●	
TLDOA1770	177.00	200.00	31.00	173.00	204.50	203.40	191.00	14.50	17.00	3.10	5.00	3.00	●	
TLDOA1780	178.00	199.00	32.00	175.00	203.60	202.40	190.00	14.50	16.00	3.00	5.00	3.00	●	
TLDOC1780	178.00	199.00	32.00	175.00	203.60	202.40	190.00	14.50	16.00	3.00	5.00	3.00	●	
TLD0B1780	178.00	200.00	38.00	175.00	210.60	209.60	192.00	19.00	21.00	3.00	4.00	4.00	●	
TLDOA1800	180.00	197.40	21.40	177.00	202.20	201.90	196.00	9.40	10.60	1.20	3.00	3.00	●	
TLDOA1823	182.30	210.30	38.00	179.30	215.40	214.40	197.50	18.40	20.30	3.70	6.30	6.30	●	
TLDOA1824	182.40	210.30	46.00	179.40	215.40	214.40	197.50	18.40	24.10	3.70	6.30	6.30	●	
TLD0B1830	183.00	202.00	28.00	179.00	206.00	205.00	195.00	12.50	14.50	2.80	5.00	3.00	●	
TLDOA1860	186.00	203.00	25.40	182.00	205.70	204.90	190.50	14.50	16.00	2.30	2.80	3.20	●	
TLD0D1910	191.00	210.00	28.00	187.00	214.00	213.00	203.00	12.50	14.50	2.80	5.00	3.00	●	
TLDOA1910	191.00	210.00	28.00	187.00	214.00	213.00	203.00	12.50	14.50	2.80	5.00	3.00	●	
TLDOA1910	191.00	210.00	28.00	187.00	214.00	213.00	203.00	12.50	14.50	2.80	5.00	3.00		●
TLDOA1920	192.00	215.00	33.00	189.00	220.80	219.80	207.00	16.50	18.50	3.00	4.00	4.00	●	
TLDOA1920	192.00	215.00	33.00	189.00	220.80	219.80	207.00	16.50	18.50	3.00	4.00	4.00		●
TLDOA1950	195.00	216.50	32.00	191.00	221.00	220.00	207.00	14.50	17.00	2.80	5.00	3.00	●	
TLDOA2000	200.00	228.50	38.00	196.00	233.50	232.50	215.50	18.00	20.50	3.00	6.30	6.30	●	
TLDOA2020	202.00	222.30	26.50	197.00	224.90	224.10	217.90	11.80	14.20	2.90	2.80	3.00	●	
TLDOA2050	205.00	227.00	30.00	201.00	231.50	230.50	219.00	14.50	17.00	2.80	5.00	3.00	●	
TLD0B2050	205.00	227.00	31.60	201.00	231.50	230.50	219.00	14.50	17.00	2.80	5.00	3.00	●	
TLDOA2087	208.70	222.80	26.00	205.00	225.40	224.40	217.00	11.50	13.50	2.20	2.50	3.00	●	

Seat Ramp Angle is 10°, except for a few exceptions shown in the notes at the bottom of the page.

1) 15° 2) 12° 3) 12°30' 4) 9°30'

All sizes in Bearing Steel (BS) could also be requested in Cast Iron (CI)



TSS Part No.	D _i	D _a	L	d _{max.}	D	D ₁	D ₃	L ₁	L _{2min.}	L ₄	r	S	BS	CI
TLDOA2090	209.00	234.00	42.00	206.00	242.60	241.60	224.00	19.50	22.50	3.00	4.00	4.00	●	
TLDOA2090	209.00	234.00	42.00	206.00	242.60	241.80	224.00	19.50	21.50	3.00	4.00	4.25		●
TLDOA2200	220.00	239.50	31.80	215.00	244.00	243.00	232.00	14.50	16.50	2.80	5.00	3.00	●	
TLDOA2200	220.00	239.00	31.80	217.00	244.00	243.00	232.00	14.50	16.50	2.80	5.00	3.00		●
TLDOC2200	220.00	239.50	31.80	215.00	244.00	243.00	232.00	14.50	16.50	2.80	5.00	3.00	●	
TLDOB2200	220.00	241.40	25.00	215.00	244.70	244.00	232.00	11.00	13.50	2.20	4.00	3.00	●	
TLDOA2235	223.50	251.40	38.00	220.50	256.50	255.70	238.70	18.40	20.30	3.70	6.30	6.30	●	
TLDOC2235	223.50	251.50	46.00	220.50	256.60	255.70	238.70	18.40	24.10	3.70	6.30	6.30	●	
TLDOA2240	223.50	252.00	38.00	220.00	256.60	255.70	238.00	18.00	20.00	3.10	6.40	3.00		●
TLDOA2250	225.00	252.00	38.00	221.00	258.00	257.00	241.00	19.00	21.00	3.00	4.00	4.00	●	
TLDOA2316	231.60	259.60	38.00	227.00	264.70	263.80	247.00	18.40	20.50	3.70	6.30	6.30	●	
TLDOA2350	235.00	259.60	38.00	231.00	264.70	263.80	247.00	18.40	20.50	3.70	6.30	6.30	●	
TLDOA2380	238.00	261.00	32.00	234.00	265.50	264.50	254.00	14.50	17.00	2.80	5.00	3.00	●	
TLDOA2390	239.00	268.00	40.00	235.00	274.20	273.20	257.00	20.50	22.50	3.00	4.00	4.00	●	
TLDOC2400	240.00	262.80	38.00	236.00	273.50	272.50	255.50	18.00	20.50	3.10	6.50	3.00	●	
TLDOA2400	240.00	262.80	38.00	237.00	273.50	272.50	257.00	19.00	21.00	3.00	4.00	4.00		●
TLDOA2450	245.00	264.50	32.00	241.00	268.90	267.90	255.00	14.50	17.00	2.80	5.00	3.00	●	
TLDOB2500	250.00	276.00	44.00	247.00	284.60	283.60	266.00	20.50	24.00	3.00	4.00	4.00	●	
TLDOA2500	250.00	276.00	41.00	247.00	284.60	283.60	266.00	20.50	22.50	3.00	4.00	4.00		●
TLDOA2520	252.00	280.00	38.00	248.00	285.50	284.50	265.00	18.00	20.00	3.10	6.50	3.00	●	
TLDOA2650	265.00	292.80	38.00	261.00	297.80	297.00	280.00	18.00	20.50	3.70	6.30	6.30	●	
TLDOB2650	265.00	292.80	46.00	261.00	297.80	297.00	280.00	18.40	24.10	3.70	6.30	6.30	●	
TLDOA2650	265.00	293.00	38.00	262.00	298.00	297.00	280.00	19.00	21.00	3.00	6.40	4.00		●
TLDOA2750	275.00	303.00	38.00	271.00	308.00	307.00	290.00	18.00	20.50	3.10	6.50	3.00	●	
TLDOA2750	275.00	303.00	38.00	271.00	308.00	307.00	290.00	18.00	20.50	3.10	6.4	4.00		●
TLDOA2829	282.90	310.80	38.00	280.00	316.30	315.40	298.40	18.40	20.30	3.70	6.30	6.30	●	
TLDOA3000	300.00	325.00	38.00	296.00	335.50	334.50	318.00	17.50	20.50	3.10	6.50	3.00	●	
TLDOB3000	300.00	328.00	40.00	296.00	333.00	332.00	315.00	18.50	21.00	3.00	4.00	4.00	●	
TLDOB3000	300.00	328.00	39.00	297.00	333.00	332.00	315.00	19.50	22.00	3.00	4.00	4.00		●
TLDOA3010	301.00	328.00	38.00	297.00	333.00	332.10	315.10	18.40	20.30	3.70	6.30	6.30	●	
TLDOA3190	319.00	346.50	46.00	315.00	351.60	350.70	333.70	18.40	24.10	3.70	6.30	6.30	●	
TLDOA3185	318.50	346.50	38.00	315.50	351.60	350.70	333.70	18.40	20.30	3.70	6.30	6.30	●	
TLDOA3180	318.50	341.00	38.00	315.00	351.60	350.70	335.00	19.00	21.50	3.00	6.40	4.00		●
TLDOA3180	318.00	341.40	38.00	315.00	351.50	350.50	334.00	18.00	20.50	3.10	6.50	3.00	●	
TLDOA3395	339.50	369.00	40.00	335.00	374.80	373.80	358.00	19.00	21.50	3.00	4.00	4.00	●	
TLDOA3400	340.00	369.00	40.00	337.00	374.80	373.80	358.00	19.00	21.50	3.00	4.00	3.00	●	
TLDOA3400	340.00	368.00	38.00	333.00	375.70	374.80	358.00	19.60	22.10	3.10	4.00	2.00		●
TLDOA3500	350.00	375.00	38.00	345.00	385.50	384.50	368.00	17.50	20.50	3.10	6.50	3.00	●	
TLDOD3665	366.50	394.50	48.00	363.50	399.50	398.60	381.70	18.40	24.10	3.70	6.30	6.30	●	
TLDOA3665	366.50	394.50	37.00	363.00	399.50	398.60	382.00	18.50	21.00	3.00	6.40	4.00		●
TLDOB3665	366.50	391.00	38.00	363.00	399.50	398.50	381.80	18.50	21.00	3.00	4.00	4.00		●
TLDOC3665	366.50	394.40	38.00	363.50	399.50	398.60	381.70	18.40	20.30	3.70	6.30	6.30	●	
TLDOA3700	370.00	398.00	38.00	365.00	403.50	402.60	385.00	17.50	20.50	3.00	6.50	3.00	●	

Seat Ramp Angle is 10°, except for a few exceptions shown in the notes at the bottom of the page.

1) 15° 2) 12° 3) 12°30' 4) 9°30'

All sizes in Bearing Steel (BS) could also be requested in Cast Iron (CI)



TSS Part No.	D _i	D _a	L	d _{max.}	D	D ₁	D ₃	L ₁	L _{2min.}	L ₄	r	S	BS	CI
TLDOA3805	380.50	405.00	40.00	375.00	412.20	410.50	395.00	17.00	22.00	3.00	4.00	4.00	●	
TLDOA3870	387.00	415.00	38.00	382.00	420.30	419.30	402.00	17.50	20.50	3.00	6.50	3.00	●	
TLDOA3870	387.00	415.00	38.00	384.00	419.50	418.50	400.00	18.00	20.50	3.00	4.00	3.00		●
TLDOA4285	428.50	454.00	37.00	425.00	462.30	461.30	444.60	18.50	21.00	3.00	4.00	4.00	●	
TLDOA4290	429.00	457.00	38.00	426.00	463.50	462.50	444.00	18.00	20.50	3.00	4.00	3.00		●
TLDOA4292	429.20	457.20	38.00	426.20	462.30	461.40	444.40	18.40	20.30	3.70	6.30	6.30	●	
TLDOB4292	429.20	457.20	38.00	426.20	463.50	462.50	444.00	18.00	20.50	3.10	6.50	3.00	●	
TLDOA4700	470.00	500.00	50.00	465.00	512.20	510.20	490.00	23.50	25.50	4.00	6.00	3.00	●	
TLDOA5054	505.40	533.40	44.00	502.40	538.50	537.60	520.60	21.30	26.20	3.70	6.30	6.30	●	
TLDOA5300	530.00	560.00	50.00	524.00	572.20	570.20	545.00	23.50	25.50	4.00	6.00	3.00	●	
TLDOA5800	580.00	608.00	43.60	575.50	613.00	611.00	596.00	19.70	21.70	4.00	6.50	6.00	●	
TLDOA5910	591.00	623.00	50.00	585.00	635.20	632.10	613.00	23.50	25.50	4.00	6.00	5.20	●	
TLDOA6670	667.00	700.00	44.00	660.00	705.60	704.60	687.60	18.40	23.40	3.70	6.30	6.30	●	
TLDOA7100	710.00	750.00	50.00	700.00	762.20	760.20	740.00	23.50	25.50	4.00	6.00	3.00	●	
TLDOA8300	830.00	886.00	80.00	815.00	891.60	890.60	860.00	34.50	39.50	4.40	10.00	17.00	●	

Seat Ramp Angle is 10°, except for a few exceptions shown in the notes at the bottom of the page.

1) 15° 2) 12° 3) 12°30' 4) 9°30'

All sizes in Bearing Steel (BS) could also be requested in Cast Iron (CI)

ORDERING EXAMPLE

Mechanical Face Seal Type D0

Inside diameter: Di = 125.0 mm

Materials: Seal Rings of Bearing Steel (1.3505)
O-Rings of NBR

Mechanical Face Seal Type D0

Inside diameter: Di = 240.0 mm

Materials: Cast Iron
O-Rings of NBR

TSS Article No. TLDOA 1250 - 2CP00
 TSS Part No. _____
 Inside Diameter x 10 _____
 Quality Index (Standard) _____
 Material No. _____

TSS Article No. TLDOA 2400 - 2FP00
 TSS Part No. _____
 Inside Diameter x 10 _____
 Quality Index (Standard) _____
 Material No. _____



■ Installation Recommendations for Type DF Bearing Steel

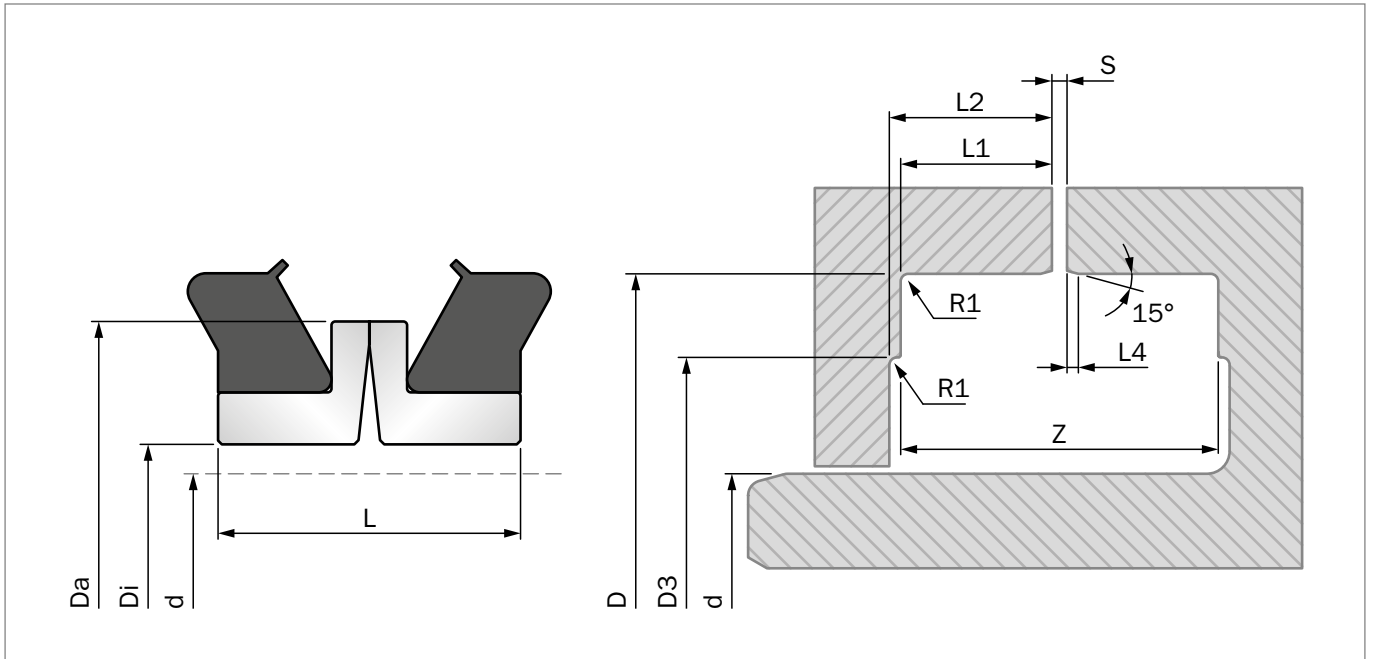

Figure 186: Installation Drawing

Table 127: Seal Group Dimensions, Type and Seat Dimensions

TSS Part No.	D _i	D _a	L	d _{max.}	D	D ₁	L ₂	L _{3min.}	L ₁	S	Z	BS	CI
TL DFA0420	42.0	59.0	20.0	38.0	65.0	53.0	10.0	10.5	9.5	3.0	23.0	●	
TL DFA0470	47.0	62.0	20.0	44.0	70.0	58.0	10.0	11.0	9.0	3.0	23.0	●	
TL DFA0505	50.5	65.0	19.0	46.0	76.2	63.0	10.0	11.0	9.0	2.5	22.5	●	
TL DFA0540	54.0	73.0	22.0	50.0	80.0	67.0	11.5	12.0	11.0	3.0	26.0	●	
TL DFA0585	58.5	73.0	19.0	54.0	82.5	65.0	10.0	11.0	9.0	3.0	23.0	●	
TL DFA0586	58.6	80.0	19.6	57.0	84.0	71.0	9.0	9.5	8.5	3.0	21.0	●	
TL DFA0635	63.5	81.0	19.0	59.5	87.8	71.0	9.0	9.5	8.5	3.0	21.0	●	
TL DFA0670	67.0	86.2	20.0	64.0	95.4	82.0	10.0	11.0	9.0	3.0	23.0	●	
TL DFB0670	67.0	87.0	25.0	64.0	95.0	81.0	12.5	13.0	12.0	4.0	29.0	●	
TL DFC0670	67.0	91.7	20.0	64.0	95.4	82.0	10.0	11.0	9.0	3.0	23.0	●	
TL DFA0680	68.0	86.2	20.0	64.0	95.6	82.0	10.0	11.0	9.0	3.5	23.5	●	
TL DFA0738	73.8	92.8	20.0	70.0	102.2	88.0	10.0	11.0	9.0	3.0	23.0	●	
TL DFA0740	74.0	99.0	20.0	70.0	102.2	88.0	10.0	11.0	9.0	3.0	23.0	●	
TL DFA0770	77.0	97.0	25.0	74.0	105.0	87.0	12.5	13.5	11.5	4.0	29.0	●	
TL DFA0817	81.7	101.5	20.0	70.0	110.2	96.0	10.0	11.0	9.0	3.0	23.0	●	
TL DFA0825	82.5	100.0	22.0	78.0	114.3	97.0	11.0	12.0	11.0	3.5	25.5	●	
TL DFA0875	87.5	109.0	17.5	83.0	113.0	100.0	8.5	9.5	7.5	3.0	20.0	●	
TL DFB0875	87.5	111.5	19.0	85.0	115.8	102.0	10.0	11.0	9.0	3.0	23.0	●	
TL DFA0920	92.0	113.0	24.0	88.0	125.8	109.0	12.5	13.0	12.0	3.0	28.0	●	
TL DFA0940	94.0	112.5	24.0	90.0	125.8	109.0	12.5	13.0	12.0	3.0	28.0	●	
TL DFA0990	99.0	120.0	17.5	95.0	124.0	110.0	8.5	9.5	7.5	3.0	20.0	●	



TSS Part No.	D _i	D _a	L	d _{max.}	D	D ₁	L ₂	L _{3min.}	L ₁	S	Z	BS	CI
TLDFB0990	99.0	123.0	19.0	95.0	127.3	113.0	10.0	11.0	9.0	3.0	23.0	●	
TL DFA1040	104.0	126.0	24.0	100.0	135.0	114.0	12.0	13.0	11.0	4.0	28.0	●	
TLDFB1050	105.0	124.0	24.4	101.0	134.9	125.0	13.3	14.5	12.1	3.0	29.6	●	
TLDFB1140	114.0	138.0	26.0	110.0	148.0	126.0	12.0	13.0	11.0	4.0	28.0	●	
TL DFA1180	118.0	142.0	29.0	114.0	152.4	131.4	16.3	16.3	14.3	2.0	34.6		●
TL DFA1240	124.0	144.0	32.0	119.0	162.5	141.5	18.5	20.5	16.5	3.0	40.0	●	
TL DFA1330	133.0	156.0	28.0	128.0	171.5	151.0	13.0	14.0	12.0	6.5	32.5	●	
TL DFA1485	148.5	168.0	32.4	143.0	184.1	164.0	16.5	17.5	15.5	5.0	38.0	●	
TL DFA1500	150.0	175.0	30.0	145.0	190.0	170.0	15.0	15.5	14.5	5.0	35.0	●	
TL DFA1540	154.0	180.0	36.0	149.0	194.0	174.0	18.4	20.0	16.8	4.5	41.3	●	
TL DFA1580	158.0	180.0	18.0	153.0	190.0	174.0	8.0	10.0	6.0	6.0	22.0	●	
TL DFA1690	169.0	195.0	33.0	164.0	206.2	191.5	15.1	18.4	11.8	5.0	35.2	●	
TL DFA1777	177.7	207.0	29.0	173.0	218.9	197.0	16.6	17.5	15.0	3.0	36.2	●	
TL DFA1795	179.5	207.0	29.0	173.0	218.9	197.0	16.6	17.5	15.7	3.0	36.2	●	
TL DFA1930	193.0	214.3	31.0	187.0	238.9	215.0	19.4	20.4	18.4	3.0	41.8	●	
TL DFA1940	194.0	214.5	31.0	188.0	238.8	214.0	20.1	21.0	19.2	3.0	43.2	●	
TL DFA1980	198.0	224.0	35.0	195.0	245.0	223.0	17.0	17.5	16.5	6.0	40.0	●	
TL DFA2280	228.0	260.5	41.0	221.0	277.1	247.5	23.5	24.5	22.5	4.0	51.0	●	
TL DFA2330	233.0	259.0	35.0	229.0	280.0	250.0	17.0	18.0	16.0	6.0	40.0	●	
TL DFA2415	241.5	273.5	36.0	235.0	279.4	260.6	17.5	20.0	15.0	2.0	37.0	●	
TLDFB2415	241.5	273.5	33.0	235.0	279.4	260.6	17.5	20.0	16.5	2.0	36.5	●	
TL DFA2750	275.0	303.0	36.0	270.0	309.4	290.0	17.5	20.0	15.0	2.0	37.0	●	
TL DFA2750	275.0	303.0	36.0	270.0	309.4	290.0	17.5	20.0	16.5	2.0	37.0		●
TL DFA2830	283.0	305.0	42.0	278.0	329.4	307.0	18.5	22.1	14.9	3.0	40.0	●	
TL DFA3200	320.0	352.5	40.0	312.0	365.1	343.0	20.0	21.5	18.5	2.0	42.0	●	
TL DFA3550	355.5	392.0	39.6	345.0	401.7	380.0	23.0	24.0	22.0	1.8	47.8	●	
TL DFA4420	442.0	470.0	41.0	435.0	488.7	467.0	18.4	22.0	14.8	2.5	39.3	●	
TL DFA4920	492.0	530.0	43.0	480.0	546.1	532.0	19.9	24.4	15.4	2.0	41.8	●	

All sizes in Bearing Steel (BS) could also be requested in Cast Iron (CI).

ORDERING EXAMPLE

Mechanical Face Seal Type DF in Bearing Steel

Inside diameter: Di = 150 mm

Materials: Sealing Ring of Bearing Steel
Square Ring of NBR

TSS Article No. TL DFA 1500 - 2CP00

TSS Part No. _____

Inside Diameter x 10 _____

Quality Index (Standard) _____

Material No. _____



Storage Advice

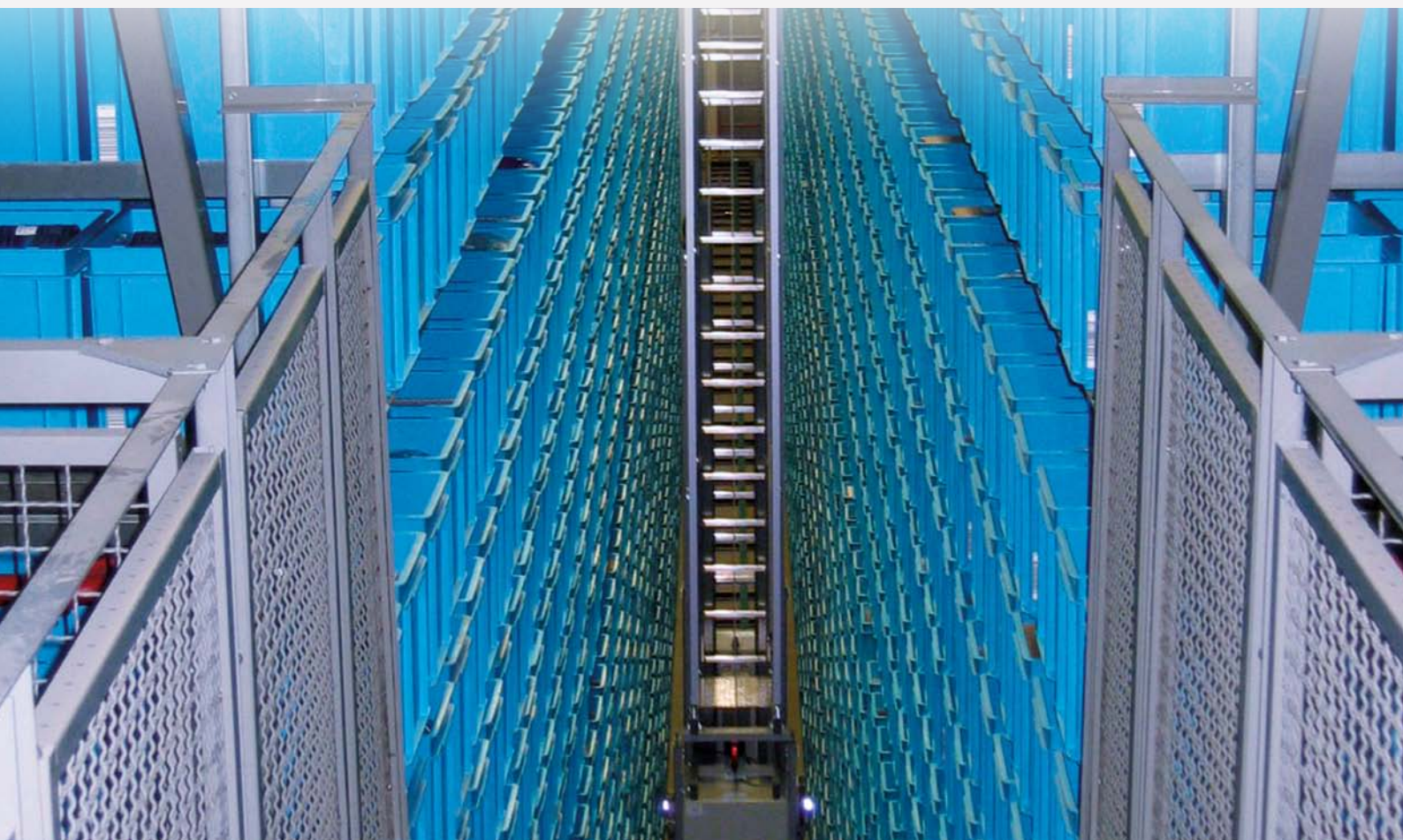

■ General Quality Criteria

The cost-effective use of seals and bearings is highly influenced by the quality criteria applied in production. Seals and bearings from Trelleborg Sealing Solutions are continuously monitored according to strict quality standards from material acquisition through to delivery.

Certification of our production plants in accordance with international standards QS 9000/ISO 9000 meets the specific requirements for quality control and management of purchasing, production and marketing functions.

Our quality policy is consistently controlled by strict procedures and guidelines which are implemented within all strategic areas of the company.

All testing of materials and products is performed in accordance with accepted test standards and specifications, e.g. random sample testing in accordance with ISO 2859-1:2004-01 AQL 1,0 general inspection level II, normal inspection.

Inspection specifications correspond to standards applicable to individual product groups (e.g. for O-Rings: ISO 3601). Our sealing materials are produced free of chlorofluorinated hydrocarbons and carcinogenic elements.

■ Guidelines for the Storage of Polymer Products Based on ISO 2230

Many polymer products and components are stored for long periods of time before being put into service, so it is important they are stored in conditions that minimize unwanted changes in properties. Such changes may result from degradation, in which case they may include excessive hardening, softening, cracking, crazing and other surface effects. Other changes may be caused by deformation, contamination or mechanical damage.

Packaging

Unless otherwise specified in the appropriate product specification, rubber products should be enclosed in individual sealed envelopes. The packaging should be carried out in an atmosphere in which the relative humidity is less than 70%, or if polyurethanes are being packed, less than 65%. Where there is serious risk of ingress of moisture (e.g. rubber-metal-bonded parts), aluminum foil/paper/polyethylene laminate or other similar means of protection should be used to ensure protection from ingress of moisture.

Temperature

The storage temperature should be below +25 °C and the products should be stored away from direct sources of heat such as boilers, radiators and direct sunlight. If the storage temperature is below +15 °C, care should be exercised during handling of stored products, as they may have stiffened and have become susceptible to distortion if not handled carefully.

Humidity

The relative humidity should be such that, given in the variations of temperature in storage, condensation does not occur. In all cases, the relative humidity of the atmosphere in storage should be less than 70%, or if polyurethanes are being stored, less than 65%.

Light

Rubber should be protected from light sources, in particular direct sunlight or intense light having a high ultra-violet content. It is advisable that any windows of storage rooms be covered with a red or orange coating or screen.

Radiation

Precautions should be taken to protect stored products from all sources of ionizing radiation likely to cause damage to the products.

Ozone

Ozone has a particularly harmful effect on rubber. Storage rooms should not contain any equipment that is capable of generating ozone, such as mercury vapor lamps or high-voltage electrical equipment giving rise to electric sparks or electrical discharges. Combustion gases and organic vapors should also be excluded, as they may give rise to ozone via photo-chemical processes. When equipment such as a fork-lift truck is used to handle large rubber products, care needs to be taken to ensure this equipment is not a source of pollution that may affect the rubber. Combustion gases should be considered separately. While they are responsible for generating ground-level ozone, they may also contain unburned fuel which, by condensing on rubber products, can cause additional deterioration.

Deformation

Rubber should be stored free from tension, compressive stresses or other causes of deformation. Where products are packaged in a strain-free condition, they should be stored in their original packaging. In case of doubt, the manufacturer's advice should be sought. It is advisable that rings of large internal diameter are formed into three equal loops so as to avoid creasing or twisting. It is not possible to achieve this condition by forming just two loops.

Contact with liquids and semi-liquid materials

Rubber should not be allowed to come into contact with liquid or semi-liquid materials (for example, petrol, greases, acids, disinfectants, cleaning fluids) or their vapors at any time during storage, unless these materials are by design an integral part of the product or the manufacturer's packaging. When rubber products are received coated with their operational media, they should be stored in this condition.

Contact with metals

Certain metals and their alloys (in particular, copper and manganese) are known to have harmful effects on some rubbers. Rubber should not be stored in contact with such metals except when bonded to them. They should be protected by wrapping in, or by separation with, a suitable material, e.g. paper or polyethylene.

Contact with dusting powder

Dusting powders should only be used for the packaging of rubber items in order to prevent adhesion. In such cases, the minimum quantity of powder to prevent adhesion should be used. Any powder used should be free from any constituent that would have a harmful effect on the rubber or the subsequent application of the rubber.

Contact between different products

Contact between products made from rubbers of different compositions should be avoided. This includes products of the same type but differing in color.

Rubber-to-metal bonded products

The metal part of rubber-to-metal bonded products should not come into contact with the rubber of other products. Preservative used on the metal should be of a type that it will not adversely affect the rubber or the bond to such an extent that it does not comply with the product specification.

Storage life

This is the maximum period of time that a rubber product, appropriately packaged, may be stored. After this time the product is regarded as unserviceable for the purposes for which it was originally manufactured. The storage life of a rubber product is influenced by its shape and size as well as its composition. Thick products usually undergo slower changes through degradation than thinner ones.

Initial storage period

This is the maximum period, starting from the time of manufacture, for which a rubber product, appropriately packaged, may be stored under specified conditions before a sample needs to be inspected or re-tested.

Extension storage period

This is the period for which a rubber product, appropriately packaged, may be stored after the initial storage period, before further inspection and re-testing is necessary.

Assembly

These are products or components containing more than one element, one or more of which is made of rubber. Generally it is not recommended to store elastomeric products in an assembled condition. If it is necessary to do so, the units should be checked more often. The inspection interval depends on the design and geometry of the components.

Inspection before extension storage

Before any items are to be stored for an extension period, representative samples of each type should be selected for inspection at the end of the appropriate initial storage period. Inspection should be in accordance with the relevant product specification.

Visual inspection

Inspect each of the items for the following:

1. Permanent distortions, such as creases or flats.
2. Mechanical damage, such as cuts, tears, abraded areas or delaminated plies.
3. Surface cracking when viewed under a microscope at x10 magnification.
4. Changes in surface condition, such as hardening, softening or tackiness.

Assessment at the end of the initial period

If, following the visual inspection procedure the items are not satisfactory, they should not be stored for an extended period. If the items are satisfactory and are stored for an extended period a record should be kept of the date initial storage began as well as the date the extended storage period began. Items stored for an extended period should be inspected and tested at, or before, the expiry of the extension storage period before they are put into service or stored for a further extended period.

Table 128: Initial and extension storage periods for unassembled components

Material Group	Initial Storage Period	Extended Storage Period
AU, EU, NR, SBR	5 years	2 years
ACM, AEM, CR, ECO, HNBR, IIR, NBR	7 years	3 years
CSM, EPDM, FKM, FMQ, FVMQ	10 years	5 years
FFKM Isolast®	20 years	5 years
Zurcon®	10 years	5 years
PTFE	unlimited	

Note 1: If the storage temperature is over or under +25 °C / +77 °F this will influence the storage time. Storage at +10 °C higher will reduce the storage time by about 50%. Storage at +10 °C / +18 °F lower will increase the storage time by around 100%.

Note 2: In application areas such as aerospace the storage periods can differ from this specification. These specific storage conditions have to be agreed between the supplier and the buyer.

Trelleborg is a world leader in engineered polymer solutions that seal, damp and protect critical applications in demanding environments. Its innovative solutions accelerate performance for customers in a sustainable way.

Trelleborg Sealing Solutions is a leading developer, manufacturer and supplier of precision seals, bearings and custom-molded polymer components. It focuses on meeting the most demanding needs of aerospace, automotive and general industrial customers with innovative solutions.

WWW.TSS.TRELLEBORG.COM



facebook.com/TrelleborgSealingSolutions
twitter.com/TrelleborgSeals
youtube.com/TrelleborgSeals
linkedin.com/company/trelleborg-sealing-solutions

If you'd like to talk to Trelleborg Sealing Solutions, find your local contact at: www.tss.trelleborg.com/worldwide